

PALLET HANDLING EQUIPMENT

HEAVY-DUTY SERIES

Rugged construction makes these pallet trucks the best value for your material handling needs. Forks feature entry rollers and tapered design for easy pallet entry and are reinforced for heavy-duty loads. The 3-function hand control (raise, neutral and lower) and the spring-loaded self-righting safety loop handle enhance comfort and ease of operation. Hardened chrome piston with protective dust cover for dependable performance. Durable powder coat finish.

HYDRAULIC PALLET TRUCKS

- Heavy-duty polyurethane tread bonded to cast iron core steering wheels and rollers provide superior performance
- 6 1/4" (158.75 mm) wide forks
- High visibility orange
- **2-year limited warranty**



Model No.	Forks		Frame Width"	Fork Length"	Capacity lbs.
	Lowered"	Raised"			
MJ484	27/8	73/4	20 1/2	36	5500
MJ485	27/8	73/4	20 1/2	42	5500
MJ486	27/8	73/4	20 1/2	48	5500
MJ487	27/8	73/4	27	36	5500
MJ488	27/8	73/4	27	42	5500
MJ489	27/8	73/4	27	48	5500
ML372*	27/8	73/4	27	48	5500

* Heavy-duty nylon wheels

HYDRAULIC PALLET TRUCKS

- Heavy-duty polyurethane tread bonded to cast iron core steering wheels and rollers provide superior performance
- Double rollers for easy moving of extra heavy loads
- Reinforced fork channels deliver exceptional durability
- 6 1/4" (158.75 mm) wide forks
- Kleton blue
- **2-year limited warranty**



Forks feature double entry rollers and tapered design for easy pallet entry

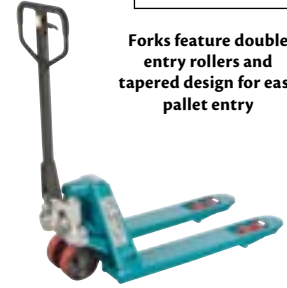

Model No.	Forks		Frame Width"	Fork Length"	Capacity lbs.
	Lowered"	Raised"			
MJ490	27/8	73/4	20 1/2	36	6600
MJ491	27/8	73/4	20 1/2	42	6600
MJ492	27/8	73/4	20 1/2	48	6600
MJ493	27/8	73/4	27	36	6600
MJ494	27/8	73/4	27	42	6600
MJ495	27/8	73/4	27	48	6600
ML373*	27/8	73/4	27	48	6600

* Heavy-duty nylon wheels

STANDARD-DUTY HYDRAULIC PALLET TRUCKS

- Heavy-duty polyurethane tread bonded to cast iron core steering wheels and rollers provide superior performance
- Heavy-duty plastic rollers facilitate entry and exit of pallets
- 6 1/4" (158.75 mm) wide forks
- High visibility yellow
- **1-year limited warranty**



Model No.	Forks		Frame Width"	Fork Length"	Capacity lbs.
	Lowered"	Raised"			
ML966	3 1/8	73/4	20 1/2	36	5500
ML967	3 1/8	73/4	20 1/2	42	5500
ML968	3 1/8	73/4	20 1/2	48	5500
ML969	3 1/8	73/4	27	36	5500
ML970	3 1/8	73/4	27	42	5500
ML971	3 1/8	73/4	27	48	5500
ML972*	3 1/8	73/4	27	48	5500

* All nylon core steering wheels and rollers

SUPER HEAVY-DUTY HYDRAULIC PALLET TRUCK

- Extra heavy-duty all steel steering wheels and rollers provide maximum mobility and performance
- Double rollers for easy moving of extra heavy loads
- Heavy-duty plastic exit rollers facilitate entry and exit of pallets
- 6 1/4" (158.75 mm) wide forks
- Dark blue
- **2-year limited warranty**



Model No.	Forks		Frame Width"	Fork Length"	Capacity lbs.
	Lowered"	Raised"			
ML994	3	73/8	27	48	11 000

LONG FORK 6' HYDRAULIC PALLET TRUCKS

- Heavy-duty polyurethane tread bonded to cast iron core steering wheels and rollers provide superior performance
- Nylon exit roller facilitates entry and exit of pallets
- 6 1/4" (158.75 mm) wide forks
- Lowered pallet truck height: 3"
- Raised pallet truck height: 7 5/8"
- High visibility orange
- **2-year limited warranty**



Model No.	Frame Width"	Fork Length"	Capacity lbs.
MN058	27	72	5500

LOW PROFILE HYDRAULIC PALLET TRUCKS

- Permits the handling of pallets and containers that are lower than the standard height
- Heavy-duty polyurethane tread bonded to cast iron core steering wheels and all steel rollers provide superior performance
- 1.5" exit ramp facilitates exit of pallets
- 6" (152 mm) wide forks
- Lowered pallet truck height: 2"
- Raised pallet truck height: 5 1/2"
- High visibility orange
- **2-year limited warranty**



Model No.	Frame Width"	Fork Length"	Capacity lbs.
MN061	27	48	5500

PALLET HANDLING EQUIPMENT

MULTI-DIRECTIONAL HYDRAULIC PALLET TRUCKS

- Transrollers permit lateral movement in addition to forward/backward
- Heavy-duty polyurethane tread bonded to cast iron core steering wheels provide superior performance
- Double load rollers, one polyurethane tread bonded to cast iron core and one nylon for easy moving of extra heavy loads
- 2 1/5" exit ramp facilitates exit of pallets
- 6 1/4" (158.75 mm) wide forks
- Lowered pallet truck height: 3"
- Raised pallet truck height: 7 1/2"
- Capacity: Up to 5500 lbs. in standard mode and up to 3300 lbs. in lateral mode
- High visibility orange
- **2-year limited warranty**



Model No.	Frame Width"	Fork Length"
MN062	27	48



DIGITAL SCALE HYDRAULIC PALLET TRUCKS

- Permits the weighing of skids and containers while handling them
- Mettler Toledo digital cUL listed scale offers maximum precision on load weights
- Heavy-duty polyurethane tread bonded to cast iron core steering wheels and rollers provide superior performance
- Nylon roller facilitates entry and exit of pallets
- 6 5/8" (168 mm) wide forks
- Lowered pallet truck height: 3"
- Raised pallet truck height: 7 11/16"
- High visibility orange
- **2-year limited warranty**



Model No.	Frame Width"	Fork Length"	Capacity lbs.
MN063	27	48	4400



GALVANIZED HYDRAULIC PALLET TRUCKS

- Heavy-duty all nylon steering wheels and rollers provide superior mobility and performance
- Nylon exit roller facilitates entry and exit of pallets
- 6 1/4" (158.75 mm) wide forks
- Lowered pallet truck height: 3"
- Raised pallet truck height: 7 1/16"
- Galvanized finish offers corrosion resistance and is ideal for wet and cold conditions
- **2-year limited warranty**



Model No.	Frame Width"	Fork Length"	Capacity lbs.
MN059	27	48	5500



STAINLESS STEEL HYDRAULIC PALLET TRUCKS

- Heavy-duty all nylon steering wheels and rollers provide superior mobility and performance
- Nylon exit roller facilitates entry and exit of pallets
- 6 1/4" (158.75 mm) wide forks
- High grade 304 stainless steel is ideal for medical, food, sanitary, pharmaceutical, wet and cold applications
- **2-year limited warranty**



Model No.	Lowered"	Fork Height Raised"	Frame Width"	Fork Length"	Capacity lbs.
MN060	3	7 1/16	27	48	5500



4-WAY HYDRAULIC PALLET TRUCKS

- Can enter pallet from all four sides
- Reinforced forks
- Adjustable fork connecting rods
- Steel 1.70" load wheels
- 6" polyurethane steering wheels
- **3-year limited warranty**



Model No.	Frame Width"	Fork Length"	Capacity lbs.
MN136	33	44	4000



BRAKE PALLET TRUCKS

- Hand-operated automotive style drum brake provides greater load control
- 7" mold-on polyurethane steering wheels
- 3" mold-on polyurethane load wheels
- 6" wide forks
- Overall fork width: 27"
- Overall fork length: 48"
- Capacity: 5500 lbs.
- Weight: 215 lbs.
- **2-year limited warranty**

Model No. MN114



PALLET HANDLING EQUIPMENT

ADJUSTABLE WIDTH PALLET TRUCKS

- Overall fork width adjusts from 21" to 27"
- Fork length: 48"
- 7" mold-on polyurethane steering wheel
- 3" mold-on polyurethane load wheels
- 6" (152 mm) wide forks
- Raised height: 7 3/4"
- Lowered height: 3"
- Capacity: 5500 lbs.
- **5-year limited warranty**

Model No. MI820

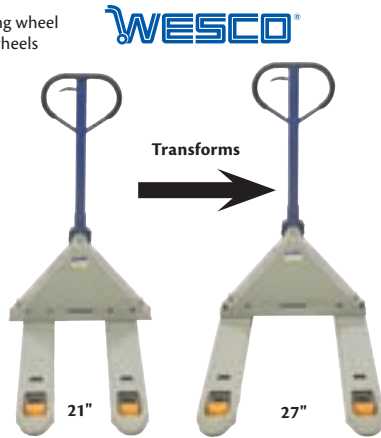

WESCO

Transforms

21"

27"

SPARK RESISTANT PALLET TRUCKS

- Non-conductive and grounded, preventing sparking in potentially-charged environments
- Brass-covered bulkhead and forks
- 6 1/2" wide forks
- 7" polyurethane steering wheels
- 2 9/10" x 3 3/5" polyurethane load rollers



Model No.	Fork Height		Frame Width"	Fork Length"	Capacity lbs.
	Lowered"	Raised"			
MN364	29/10	7 3/4	27	48	5500

Other sizes available

QUICK LIFT HYDRAULIC PALLET TRUCKS

- Maximize operator efficiency with this quick-lift pallet truck
- Lifts to full height with only four pumps when empty
- 2-speed pump automatically switches to low-speed operation
- Allows forks to quickly rise to upper pallet boards for quicker operation
- Each fork measures 6 1/4" wide
- Poly-on-steel wheels are the best in the industry



Model No.	Fork Height		Frame Width"	Fork Length"	Capacity lbs.
	Lowered"	Raised"			
MN365	3	7 1/2	20	48	5500
MN366	3	7 1/2	27	48	5500

PALLET TRUCK CADDY

- Durable molded plastic
- Economical product will convert a standard pallet truck into a portable workstation in minutes
- Overall dimensions: 16 1/4" W x 7 3/4" D x 18 5/8" H
- **Includes:** Tool pockets on each side, pen and pencil tray, clipboard holder, built-in cup or can holder, and storage compartment

Model No. MN368



POWER-START TECHNOLOGY™ PALLET TRUCKS

THE RIGHT TOOL FOR ERGONOMIC PALLET MOTION!

- Reduces starting resistance even when truck is heavily loaded
- Select travel direction via option on handgrip, squeeze the handgrip, pump the tow bar and the truck is launched in the walking direction
- When handgrip is pressed downward, and tow bar raised, the truck is launched in the direction of the forks
- **2-year limited warranty**

Specifications:

- Forks: 27" W x 48" L
- Minimum fork height: 3"
- Maximum fork height: 7 1/2"
- Rated capacity: 5000 lbs.
- Weight: 188 lbs.

Model No. MH736

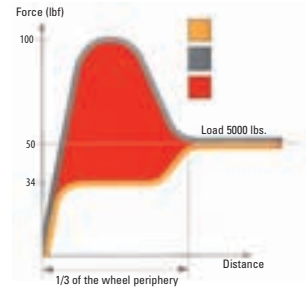

LIFT-RITE® TITAN PALLET TRUCKS

- New one-piece pump for improved performance and reliability
- Includes ergonomic handles and articulating steering wheels
- 7" wide forks
- Fork lowered height: 3"
- Fork raised height: 7 3/4"
- **2-year limited warranty**



Model No.	Frame Width"	Fork Length"	Capacity lbs.
ML052	20 1/2	36	5500
ML053	20 1/2	42	5500
ML054	20 1/2	48	5500
ML055	27	36	5500
ML056	27	42	5500
ML057	27	48	5500

Custom sizes available

UNIVERSAL PALLET TRUCK FOOTGUARDS

- Steel construction with powder-coat finish
- Prevents crushed toes and other foot injuries
- Universal design fits most manual hand pallet trucks
- Wraparound guard, floats up and down allowing for use on dock levelers and dock plates
- Offers full range of motion and does not interfere with normal pallet truck operation
- Width: 8"

Model No. MN367



LIFTING EQUIPMENT

FORK EXTENSIONS

- Handle large and odd shaped loads with increased stability and minimum damage
- Available in 4", 5" and 6" fork widths, lengths are from 54" to 96"
- Easy to use slide-on design
- Fork fits up to 2" thick
- Convenient on/off design
- Locking bar keeps extensions in place
- Fork extension not to exceed 50% more than existing fork



WALL BRACKETS

- All welded heavy-duty
- To keep fork extensions out of the way when not in use
- One wall bracket required for each pair of forks
- Kleton safety yellow



Model No.	Dimensions W" x H"	Wt. lbs
ML282	6 x 8	5

Hardware not included

Model No.	Accommodates Fork Width"	Fork Extension Overall Width"	Length"	Max. Fork Thickness"	Wt. lbs.
MF775	4	5	54	2	109
MF776	4	5	63	2	125
MF778	4	5	84	2	157
MF781	5	6	54	2	126
MF782	5	6	63	2	110
MF784	5	6	84	2	189
MF785	5	6	96	2	201
MF787	6	7	54	2 1/2	146
MF788	6	7	63	2 1/2	165
MF789	6	7	72	2 1/2	166
MF790	6	7	84	2 1/2	199
MF791	6	7	96	2 1/2	210

Also available: Add-on for optional pins style fork extension and other lengths.

FORK EXTENSIONS

- Handle large and odd shaped loads with increased stability
- Easy to use slide-on design
- Steel retaining strap prevents extensions from sliding off forks during use
- Fork extension not to exceed 50% more than existing fork
- Available in 4" and 5" fork widths, with lengths of 72" and 96"



Model No.	Accommodates Fork Width"	Fork Extension Overall Width"	Length"	Wt. lbs.
ML346	4	5	72	105
ML347	5	6	72	116
ML348	4	5	96	140

REEL DISPENSERS

- All welded, ready to use
- For winding or dispensing cable, chain, wire, rope and hose
- Turns reel handling into a one person operation
- Accommodates unlimited reel widths and all reel diameters, flanges up to 5 1/2" thick
- Rear roller adjusts to six positions
- Heavy-duty side rollers eliminate slipping or wedging between rollers and reel
- Inclined ramp permits easy loading and unloading
- Dimensions: 28" L x 9 1/4" W x 4" H
- Capacity: 3000 lbs in pairs
- Weight: 58 lbs/pair
- Must be anchored to floor
- Durable Kleton blue enamel finish

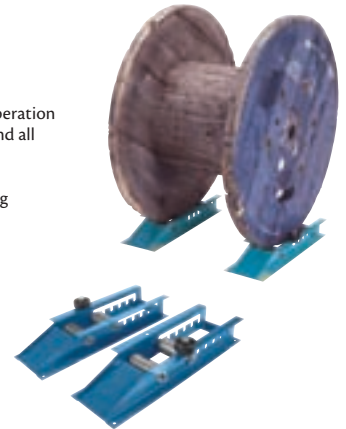

Model No. MD166



WINCH OPERATED EASY-LIFTS

- Ideal for use in factory, office or shipping department
- Can perform numerous functions from lifting objects to positioning products at best working height, to moving light loads without tying up heavy equipment
- Manoeuvres easily in areas too narrow for a lift truck
- Two swivel casters under forks allow the shop lifter to do a 360° turn on twice the length of the base



SPECIFICATIONS:

Capacity:.....500 lbs. at 10" load centre
 Overall height:60"
 Platform dimensions:.....20" x 20"
 Lowered platform height:.....4 1/2"
 Lift above floor:.....52"
 Wheels:.....6" diameter
 Casters:.....3" diameter
 Weight:.....98 lbs.

Model No. MA479

HYDRAULIC STACKER

- Allow workers to manoeuvre and lift heavy loads safely to comfortable needed height
- Foot pedal folds safely out of the way
- Front 5" polyurethane casters and rear 3" polyurethane wheels allow loads to move easily



SPECIFICATIONS:

Capacity:.....880 lbs.
 Overall dimensions:.....22 1/2" W x 39" D x 67 3/4" H
 Platform dimensions:.....25 3/4" L x 22 3/4" W
 Lowered platform height:.....4"
 Raised platform height:.....60"
 Weight:.....174 lbs.

Model No. MN397

LIFTING EQUIPMENT & DOLLIES

PALLET CAROUSELS

Loading and unloading operations that originally required a large amount of time can be done more efficiently with less fatigue and risk of back injury. The carousel may be added to an existing workbench, scissors table or simply placed on the floor. This *Lazy Susan* concept is constructed from two pieces of rolled structural angle. A series of roller bearings transfer the load smoothly and evenly to the supporting surface. Overall height is 2 1/4".

Model No.	Outside Diameter"	Capacity lbs.	Wt. lbs.
MH204	40	2000	48
MH205	40	4000	53
MH206	40	6000	58

Model No.	Outside Diameter"	Capacity lbs.	Wt. lbs.
MH207	48	2000	58
MH208	48	4000	61
MH209	48	6000	66



HYDRAULIC STACKERS

- Rugged frame construction
- Solid steel adjustable forks
- Designed for pallet loading and removal from racking storage even in the smallest storage spaces
- Straddle length: 42"
- Fork length: 42"
- Load centre: 24"
- Manually propelled with electric powered hydraulic lift
- Battery-powered is standard (AC power available)
- Automatic built-in battery charger included
- Other capacities available

PLEASE SPECIFY WHEN ORDERING:

Single stage stacker between 38" and 50"

Telescopic stacker between 42" and 54"

Note: Inside straddle dimension is recommended to be 2" greater than the overall pallet width (outside straddle is 6" greater than straddle inside dimension).

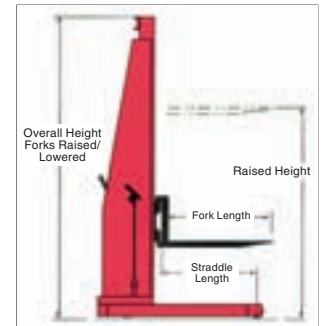
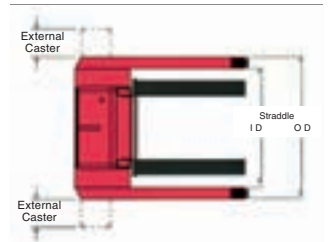

SINGLE STAGE STACKERS

Model No.	Clearance of Top Mast"	Raised Height of Top Forks"	Capacity lbs.	Wt. lbs.
LT395	72	60	1500	625
LT396	82	70	1500	638
LT397	92	80	1500	652

Other dimensions and capacities available

TELESCOPIC (TWO STAGE) STACKERS

Model No.	Clearance of Top Mast"	Raised Height of Top Forks"	Capacity lbs.	Wt. lbs.
LT398	70	96	1500	815
LT399	82	120	1500	875
LT400	88	132	1500	900
LT401	94	144	1500	924

Other dimensions and capacities available

PRY DOLLIES

- Move heavy boxes, die blocks and machinery
- Heavy-duty nose plate gets under the load, 6" steel or wooden handle gives tremendous leverage
- Come with 5" x 2" polyurethane casters
- Use in pairs to move large objects without the need of a separate dolly



Model No.	Handle	Nose Plate"	Cap. lbs.	Wt. lbs.
MF870	Wood	6 x 3	4250	34
MF871	Steel	6 x 3 3/8	5000	35

WOOD DOLLIES

MEDIUM-DUTY

- 7/8" wood top; countersunk bolts
- Carpeted dolly will prevent marks and scratches on equipment being moved
- 3" polyolefin casters
- 900-lb. capacity
- Shipped knocked down



HEAVY-DUTY

- 1 3/4" wood top (2 x 1 1/16" pieces); countersunk bolts
- Carpeted dolly will prevent marks/scratches on equipment
- 4" resilient non-marking casters
- 1200-lb. capacity
- Shipped knocked down



Model No.	Dim. W" x D"	Platform Type	Wt. lbs.
-----------	--------------	---------------	----------

MEDIUM-DUTY			
MA186	18 x 24	Standard	26
MA187	18 x 24	Carpeted	28
MD515	18 x 30	Standard	32
MD516	18 x 30	Carpeted	34

HEAVY-DUTY			
MA188	18 x 24	Standard	30
MA189	18 x 24	Carpeted	32
MD517	18 x 30	Standard	38
MD518	18 x 30	Carpeted	40



DOLLIES

HARDWOOD DOLLIES

- Kiln dried
- Countersunk bolts prevent scratches
- Wood thickness: 7/8"
- Rounded edges and handles facilitate storage and movability
- Non-marking casters
- Shipped knocked down



MN204



MN217



MN200



REPLACEMENT CASTERS

Model No.	Description
ML391	3" Swivel Polyolefin
ML393	4" Swivel Polyolefin
ML044	3" Swivel Polyurethane
ML045	4" Swivel Polyurethane
ML333	4" Swivel Blue Elastic Rubber

CHOOSE FROM THREE CASTER TYPES



4" Polyolefin



3" Polyurethane



4" Blue Elastic Rubber

Model No.	Dimensions W" x D"	Caster Type	Caster"	Capacity lbs.
ALL WOOD				
MN189	18 x 24	Polyolefin	3	900
MN195	18 x 24	Polyurethane	3	900
MN201	18 x 24	Polyolefin	4	1000
MN207	18 x 24	Polyurethane	4	1600
MN213	18 x 24	Blue Elastic	4	1400
MN192	18 x 30	Polyolefin	3	900
MN198	18 x 30	Polyurethane	3	900
MN204	18 x 30	Polyolefin	4	1000
MN210	18 x 30	Polyurethane	4	1600
MN216	18 x 30	Blue Elastic	4	1400

CARPETED ENDS				
MN190	18 x 24	Polyolefin	3	900
MN196	18 x 24	Polyurethane	3	900
MN202	18 x 24	Polyolefin	4	1000
MN208	18 x 24	Polyurethane	4	1600
MN214	18 x 24	Blue Elastic	4	1400
MN193	18 x 30	Polyolefin	3	900
MN199	18 x 30	Polyurethane	3	900
MN205	18 x 30	Polyolefin	4	1000
MN211	18 x 30	Polyurethane	4	1600
MN217	18 x 30	Blue Elastic	4	1400

RUBBER ENDS				
MN191	18 x 24	Polyolefin	3	900
MN197	18 x 24	Polyurethane	3	900
MN203	18 x 24	Polyolefin	4	1000
MN209	18 x 24	Polyurethane	4	1600
MN215	18 x 24	Blue Elastic	4	1400
MN194	18 x 30	Polyolefin	3	900
MN200	18 x 30	Polyurethane	3	900
MN206	18 x 30	Polyolefin	4	1000
MN212	18 x 30	Polyurethane	4	1600
MN218	18 x 30	Blue Elastic	4	1400

WOOD DOLLY RACKS

- Convert a basic wood dolly into a multi-purpose panel caddy
- All-welded 1" tube design for durability
- Tubular steel rack is padded to prevent scratching or marring
- Durable Kleton blue enamel finish

Wood dolly not included



Model No.	Description	Wt. lbs.
MD549	Use with Wood Dolly 18" x 24"	12
MD550	Use with Wood Dolly 18" x 30"	15

STEEL DECK DOLLIES

- Heavy-duty, all-welded 14-gauge steel deck
- Four bolted-on 4" swivel non-marking rubber casters
- MA199 - Optional 34" long steel T-handle for ease of movement under full loads
- Capacity: 1200 lbs.
- Caster assembly required
- Durable Kleton blue enamel finish

MA199



MA244



Model No.	Dimensions W" x D" x H"	Wt. lbs.
MA242	18 x 18 x 7	23
MA243	18 x 24 x 7	25
MA244	24 x 24 x 7	27
MA199	34" Handle	2

ANGLE FRAME DOLLIES

- Heavy-duty all-welded 1 1/2" x 1 1/2" x 1/8" angle frame construction
- Four bolted-on 4" swivel non-marking rubber casters
- Capacity: 1200 lbs.
- Caster assembly required
- Durable Kleton blue enamel finish

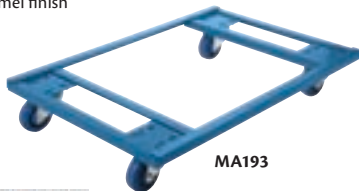

MA193



POLYETHYLENE DOLLIES

- Modular, high-impact polyethylene design
- Won't splinter, swell or rot
- Round corners and edges with channel steel reinforced sides
- 4" polyolefin swivel casters
- Capacity: 400 lbs.



MA194

Model No.	Dimensions W" x D" x H"	Platform Type	Wt. lbs.
MA194	18 x 30 x 6	Flush Deck	21
MA195	18 x 30 x 6	Padded Rubber Deck	23

ALUMINUM DECK DOLLIES

- 3/8" aluminum treadplate construction, countersunk bolts
- Four bolted-on 4" swivel non-marking casters
- Caster assembly required
- Capacity: 1200 lbs.

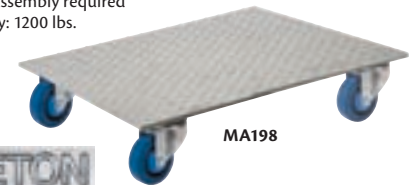

MA198

Model No.	Dimensions W" x D" x H"	Wt. lbs.
MA196	18 x 18 x 6	25
MA197	18 x 24 x 6	27
MA198	24 x 24 x 6	30



CUSTOMISE IT TO YOUR SPECIFICATIONS. SEE PAGE B60 FOR DETAILS

RUBBER WHEEL HAND TRUCKS

- Constructed of 1" 16-gauge steel tube
- 7-gauge steel nose plate
- Overall width: 19 1/2"
- Wheel dimensions: 8" x 2"
- Powder coated finish



Model No.	Description	Nose Plate Dimensions		Overall Height"	Capacity lbs.	Wt. lbs.
		W"	x D"			
MK728	Continuous Handle	14	x 8 1/2	46	600	24
MK729	Dual Handle	14	x 8 1/2	48	600	24
MN103	P-Handle	14	x 9	51	600	24

REPLACEMENT PARTS & WHEELS

Model No.	Description
ML812	Rubber Wheel
MK993	Hand Grip



MK729

MK728

MN103

PNEUMATIC WHEEL HAND TRUCKS

- Constructed of 1" 16-gauge steel tube
- 8-gauge steel nose plate
- Overall width: 21 1/2"
- Wheel dimensions: 10" x 3"
- Powder coated finish



Model No.	Description	Nose Plate Dimensions		Overall Height"	Capacity lbs.	Wt. lbs.
		W"	x D"			
MH300	Dual Handle	14	x 10	46	600	23
MH301	Continuous Handle	14	x 10	48	600	26
MH302	P-Handle	14	x 9	51	600	23

REPLACEMENT PARTS & WHEELS

Model No.	Description
ML810	Pneumatic Wheel
MK993	Hand Grip



MH301

MH300

MH302

FLAT FREE WHEEL HAND TRUCKS

- Constructed of 1", 16-gauge steel tubing
- Nose plate 8-gauge steel
- Overall width: 22"
- Wheel dimensions: 10" x 3 1/2"
- Powder-coated



Model No.	Description	Nose Plate Dimensions		Overall Height"	Capacity lbs.	Wt. lbs.
		W"	x D"			
MN389	Dual Handle	14	x 10	46	600	20
MN390	Continuous Handle	14	x 10	48	600	22
MN391	P-Handle	14	x 9	51	600	22

REPLACEMENT PARTS & WHEELS

Model No.	Description
MN378	Flat Free Wheel
MK993	Hand Grip



MN389

MN390

MN391

HEAVY-DUTY DUAL HANDLE HAND TRUCKS

- Constructed of 1 1/4" 14-gauge steel tube
- 6-gauge steel nose plate
- Overall height: 46"
- Overall width: 20"
- Powder coated finish



Model No.	Description	Wheel Dimensions"	Nose Plate Dimensions		Capacity lbs.	Wt. lbs.
			W"	x D"		
MK731	Pneumatic Wheel	10 x 3	14	x 8	800	36
MK730	Rubber Wheel	8 x 2	14	x 8	1000	36

REPLACEMENT PARTS & WHEELS

Model No.	Description
ML813	Rubber Wheel
ML811	Pneumatic Wheel
ML030	Hand Grip



MK730

MK731

HAND TRUCKS

HEAVY-DUTY SPADE TRUCKS

- All welded, ready to use
- Constructed of double-welded 1 1/4" round 14-gauge steel tubing
- Oversized nose plate and easy grip frame helps with the balancing of larger items
- Tapered 22" L x 13" D x 1/4" thick nose plate
- Two 10" mold-on rubber wheels
- Capacity: 1200 lbs.
- Durable Kleton blue enamel finish



Model No	Dimensions W" x H"	Wt. lbs.
ML324	22" x 53"	92



APPLIANCE TRUCKS

- Move large appliances easily
- Heavy-duty all welded industrial construction
- Vinyl bumpers on face of truck to prevent damage to appliances
- Heavy-duty continuous stair climbers for easy climbing/descending
- 8" solid rubber wheels
- Ratchet mechanism for easy fastening of loads
- Overall dimensions: 14 1/2" L x 24" W x 59" H
- Capacity: 550 lbs.
- Weight: 46 lbs.

Model No. ML616



VENDING MACHINE APPLIANCE TRUCKS

- Move large appliances easily
- Heavy-duty all welded industrial construction
- Vinyl bumpers on face of truck to prevent damage to appliances
- Heavy-duty continuous stair climbers for easy climbing/descending
- Fold out rear legs with two 4" swivel casters
- 8" solid rubber front wheels
- Ratchet mechanism for easy fastening of loads
- Overall dimensions: 14 1/2" L x 24" W x 66" H
- Capacity: 850 lbs.
- Weight: 65 lbs.

Model No. ML617



MOVING STRAPS

- Allows for safe movement of appliances and larger items
- Movers can constantly stay in an upright position during the move, reducing the risk of back injuries
- Nylon (5000 lbs. test)
- **Includes:** Two transport straps, 4" x 4', and two adjustable straps, 1 3/4" x 9'

Model No. MD223



HEAVY-DUTY DUAL HANDLE HAND TRUCKS

- Constructed of 1 1/4", 14-gauge steel tubing
- Nose plate 6-gauge steel
- Overall height: 46"
- Overall width: 20"
- 8" x 12" nose plate
- Powder-coated



Model No.	Description	Wheel"	Capacity lbs.	Wt. lbs.
MA376	Rubber Wheel	10 x 2	1000	40



DELUXE 12" NOSE PLATE HAND TRUCKS

- All welded, ready to use
- Constructed of 1" round 14-gauge steel tubing
- Transport short to tall loads easily
- P handle ideal for one hand control
- Strong 12" L x 14" D x 3/16" thick nose plate
- Double welded 3/16" x 1 1/2" cross bars
- Add a folding nose extension to be able to transport larger loads
- Two 10" full pneumatic wheels
- Capacity: 700 lbs.
- Durable Kleton blue enamel finish

ML321

ML322

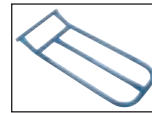

ML323
Nose Extension



Model No	Description	Overall Dimensions		Wt. lbs.
		W"	H"	
ML321	Lo-Boy	23	50	55
ML322	Hi-Boy	23	72	60
ML323	Nose Extension	12x 22" Nose Length		8

CONVERTIBLE DELUXE STEEL HAND TRUCKS

- Constructed of 1" round 14-gauge steel tubing
- Quickly converts from a 2-wheel hand truck to a 4-wheel platform truck
- 8" x 14" nose plate
- Comes with two welded-on stair glides
- Two 10" full pneumatic wheels and two 3" bolted-on casters
- Capacity: Hand truck 600 lbs. Platform truck 800 lbs.
- Durable Kleton blue enamel finish

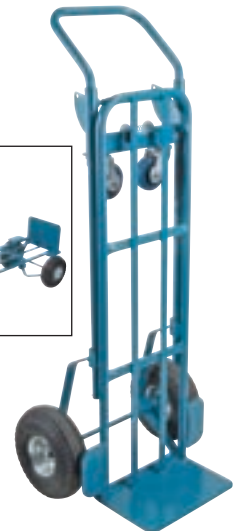

Model No	Overall Dimensions W" x D" x H"	Wt. lbs.
ML320	14 x 43 x 46	75

HAND TRUCKS WITH SWIVEL CASTERS

- 4" rear poly casters allow small diameter turns in tight areas
- Combination two handle and utility bar design reduces strain of lifting, lowering and transporting
- 8" deep nose plate
- 10" x 2 3/4" semi-pneumatic front wheels
- Overall dimensions: 20 1/2" W x 47 1/2" H
- Capacity: 800 lbs.
- Weight.: 53 lbs.

Model No. MD758



NYLON FRAME HAND TRUCKS

STRONG AS STEEL, LIGHTER THAN ALUMINUM

- Long fibre nylon frame will not mar products or damage goods
- Stair glides integrate into frame
- Aluminum loop handles, 14" W x 8" D nose plate
- Frame width: 12"
- Capacity: 500 lbs.

MN269



Model No.	Wheel Type	O.A. Height"	Wt. lbs.
FLAT BACK FRAME			
MN268	10" Rubber	52	21
MN269	10" Pneumatic	52	19
CURVED BACK FRAME*			
MN270	10" Rubber	52	21
MN271	10" Pneumatic	52	19

*Handles cylindrical or flat beds

NYLON LITE HAND TRUCKS

- Lighter than aluminum trucks
- Glass-filled nylon frame will not mark products or damage goods
- Steel handle, 14" W x 7" D steel base plate
- 10" x 3 1/2" pneumatic tires
- Frame width: 12"
- Overall height: 48"
- Capacity: 500 lbs.
- Weight: 22 lbs.

Model No. MD642



CONVERTIBLE NYLON LITE TRUCKS

- Lighter than equivalent aluminum trucks
- Glass-filled nylon frame
- Steel handle and 14 1/2" W x 7" D steel base plate
- Converts in seconds from 2-wheel hand truck to 4-wheel platform truck
- 5" swivel casters, 10" x 3 1/2" pneumatic wheels
- 12" frame width and 20 1/2" overall width



Model No.	Hand Truck Cap. lbs.	Hand Truck Height"	Platform/Truck Length	Platform/Truck Height"	Wt. lbs.
MD643	600	49 1/2	40	36	25

LOAD RETENTION HAND TRUCKS

- Constructed of 1" round 14-gauge steel tubing
- 18 1/2" x 53" load retention grill to safely handle wide and awkward loads
- 7-gauge steel nose plate
- 18 1/2" W x 9 3/4" D nose plate
- Two 10" full pneumatic wheels
- Capacity: 600 lbs.
- Durable Kleton blue enamel finish

Model No. MN412



FOLDING HAND TRUCKS

- Lightweight and durable aluminum construction
- Convenient folding design permits storage in small spaces
- Comfortable ergonomic handle
- Elastic straps help to secure load
- Non-marking and shock-absorbing rubber wheels
- Capacity: 175 lbs.
- Weight: 8.75 lbs.



Model No.	Extended Dimensions"	Folded Dimensions"	Nose Plate W" x D"	Wheel Dimensions"
ML447	39 5/8 x 15 1/2 x 16 1/2	25 x 15 x 2 3/8	15 1/4 x 11	5 x 1 1/4



BUILT 100% Canadian Owned

KLETON

TOUGH!

Kleton builds quality and dependability into all of their products. The same is true for products specially built to meet your specifications. Look throughout the catalogue for the *Kleton Custom Symbol* indicating which products can be customized to meet your specific needs.



ALUMINUM HAND TRUCKS

CONVERTIBLE HAND TRUCKS

- Lightweight aluminum construction
- Converts easily from a 2-wheel hand truck to a 4-wheel platform truck
- 5" polyurethane casters and 10" flat free wheels
- Shipped assembled



Model No.	Nose Plate W" x D"	Hand Truck		Platform Truck		Wt. lbs.
		Cap. lbs.	Height"	Cap. lbs.	L" x W"	
ML621	18 x 10	600	52	1250	12 x 43	54



ALUMINUM HAND TRUCKS

- Strong lightweight hand truck provides exceptional durability and versatility
- Weld-free design for easy maintenance
- 500 lbs. capacity
- Shipped knocked down



Model No.	Nose Plate W" x D"	Overall Height"	Wheels	Wt. lbs.
A. MN024	14 x 7 1/2	48	8" Mold-On	17.5
B. MN025	18 x 7 1/2	48	8" Mold-On	20.5
C. MN026	14 x 7 1/2	52	10" Pneumatic	21.5
D. MN027	18 x 7 1/2	48	8" Mold-On	20
E. MN028	18 x 7 1/2	52	10" Pneumatic	23
E. MN029	18 x 7 1/2	52	10" Flat-Free	20
F. MN030	14 x 7 1/2	52	10" Pneumatic	22
G. MN031	18 x 10	52	10" Pneumatic	26.5
G. MN032	18 x 10	52	10" Flat-Free	23
H. MN033	18 x 7 1/2	52	10" Pneumatic	23.5
I. MN034	14 x 7 1/2	48	10" Flat-Free	20

HAND TRUCK ACCESSORIES



FRAME EXTENSIONS

- Size: 17"
Model No. MN021
- Size: 23"
Model No. MN022



STAIR CLIMBERS

Model No. MN015



NOSE EXTENSIONS

- Only compatible with cast nose plates
- Size: 20"
Model No. MN019
- Size: 27"
Model No. MN020

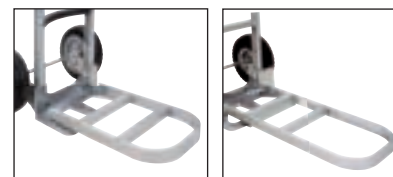

REPLACEMENT WHEELS

- 10" Pneumatic
Model No. MN012
- 8" Mold-on rubber
Model No. MN013
- 10" Flat-free
Model No. MN014



ALUMINUM HAND TRUCKS

BUILD YOUR OWN HAND TRUCK IN 4 EASY STEPS

KLETON

STEP 1: SELECT YOUR HANDLE



• Standard loop with rubber sleeve
Model No. ML997



• Standard loop
Model No. ML998



• Vertical loop
• Not for use with MN006 and MN007
Model No. ML999



• Double grip
Model No. MN001



• Single grip
Model No. MN002



• Double "P"
Model No. MN003

STEP 2: SELECT YOUR FRAME



• Straight frame
Model No. MN004



• Straight frame with large cross bar
Model No. MN005



• Curved back frame
Model No. MN006



• Lattice back frame
Model No. MN007



MN026

STEP 3: SELECT YOUR NOSE PLATE

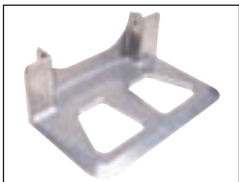

• Cast nose plate
• Dimensions: 14" x 7 1/2"
Model No. MN008

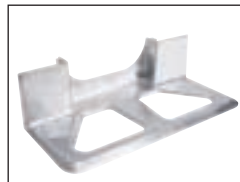

• Cast nose plate
• Dimensions: 18" x 7 1/2"
Model No. MN009



• Extruded nose plate
• Dimensions: 18" x 7 1/2"
Model No. MN010



• Extruded nose plate
• Dimensions: 18" x 10"
Model No. MN011

STEP 4: SELECT YOUR WHEEL ASSEMBLY

Assembly includes two wheels, two axle brackets and one axle



• 8" Mold-On rubber
Model No. MN035



• 10" Pneumatic
Model No. MN036



• 10" Flat-Free
Model No. MN037



MN033

ALUMINUM HAND TRUCKS

GEMINI® CONVERTIBLE ALUMINUM TRUCKS

- Converts in seconds from a 2-wheel hand truck to a 4-wheel platform truck
- Lightweight, high strength aluminum construction
- Balanced to assure easier wheeling and positive load control
- 18" W x 7 1/2" D rugged cast aluminum noseplate
- 5" swivel casters; 10" x 3 1/2" full pneumatic wheels
- 16 5/8" frame width, 20 1/2" O.A. width
- Shipped knocked down



Model No.	Gemini	Hand Truck Cap.	Hand Truck Ht."	Platform Truck Cap.	Platform Truck Ht."	Lgth."	Wt. lbs.
MA319	Jr.	500 lbs.	51	1000 lbs.	40	38	44
MA320	Sr.	500 lbs.	61	1000 lbs.	45 1/8	51	45

OPTIONAL SNAP-ON DECK

Model No.	Description	Wt. lbs.
MB198	43 1/4" for Gemini Jr.	5
MB197	56" for Gemini Sr.	6

Gemini Sr. MA320



Gemini Jr. MA319

ALUMINUM HAND TRUCKS

- Strength, durability and versatility in a lightweight truck
- Totally modular trucks have no welds to break
- 500-lb. capacity on all models
- Shipped knocked down



Model No.	Nose Plate W" x D"	Overall Ht."	Wheels	Wt. lbs
A. MA250	14 x 7 1/2	48	8" Mold-On	18
B. MA269	18 x 7 1/2	48	8" Mold-On	19
C. MA275*	14 x 7 1/2	48	10" Pneumatic	21
D. MA258	14 x 7 1/2	52	8" Mold-On	19
E. MA255	14 x 7 1/2	52	10" Pneumatic	21
E. MA263	14 x 7 1/2	48	8" Mold-On	21
E. MA261	14 x 7 1/2	48	10" Pneumatic	24
F. MA271	18 x 9	48	8" Mold-On	19
F. MA270	18 x 9	48	10" Pneumatic	22
G. MA266	18 x 7 1/2	52	8" Mold-On	19
G. MA265	18 x 7 1/2	52	10" Pneumatic	22
H. MA268	18 x 7 1/2	52	8" Mold-On	19
H. MA267	18 x 7 1/2	52	10" Pneumatic	22

* Frame has a curved back for cylindrical or flat loads



FOLDING HAND TRUCK

- Easy-to-use latch system may be engaged with one hand
- Heavy-duty construction
- Features a comfort grip handle
- 8" mold-on rubber wheels
- 14" x 7" locking folding nose plate
- Overall height: 48"
- Capacity: 500 lbs.
- Weight: 22 lbs.

Model No. MN117



THREE-POSITION HAND TRUCK

- Can be used to transport all your needs, from general use items to bulky equipment
- 18" x 7 1/2" nose plate included
- Two 10" pneumatic wheels and two 5" polyurethane casters
- Two wheel position: 500 lbs. capacity, overall height 51"
- Four wheel position: 750 lbs. capacity, overall height 40"
- Weight: 43 lbs.

Model No. MN118



Y-CABLE BRAKE HAND TRUCK

- Provides safer load control and reduces operator's accumulated muscle strain
- Easy ergonomic self-equalizing brake actuators
- Stair climber included
- 18" x 9" nose plate
- 10" pneumatic wheels
- Overall height: 60"
- Capacity: 500 lbs.
- Weight: 38 lbs.

Model No. MN119



COBRA SR. ALUMINUM 2 IN 1 TRUCKS

FEATURES

- Handle:..... Continuous
- Frame Cross Braces:..... 4
- Nose Plate:..... 18" wide
- O.A. Height:..... 61 3/4"
- Frame Bed:..... 12" x 50 3/4"
- Swivel Casters:..... 5" x 1 1/4"
- Pneumatic Wheels:..... 10" x 3 1/2"
- Hand Truck Capacity:..... 600 lbs.
- Platform Truck Capacity:..... 1250 lbs.
- Weight:..... 42.5 lbs.

Model No MD754



CURB RAMP

- Light, portable and easy to handle
- 27" x 27"
- Capacity: 600 lbs.

Model No. MH224



OPTIONAL REMOVABLE ALUMINUM DECKS

Model No.	Dimensions	
	L" x W"	
MD756	55 x 12	

ALUMINUM PLATFORM TRUCKS

- 40% lighter on average, than steel or wood-and-steel platform trucks
- Corrosion resistant for extra long life
- Box frame made of high strength all-welded aluminum channel
- Corner sockets at both ends allow handles to be used on either end of the truck
- Rubber corner bumpers prevent damage to walls and furniture
- Wide variety of casters to suit any application



8" PNEUMATIC CASTERS

Platform Dimensions"	Capacity lbs.	Smooth Deck Model No.	Wt. lbs.	Tread Plate Deck Model No.	Wt. lbs.
24 x 36	1400	ML901	51	ML904	52
24 x 48	1400	ML902	55	ML905	57
30 x 60	1400	ML903	66	ML906	68

10" PNEUMATIC CASTERS

Platform Dimensions"	Capacity lbs.	Smooth Deck Model No.	Wt. lbs.	Tread Plate Deck Model No.	Wt. lbs.
24 x 36	1850	ML907	56	ML910	57
24 x 48	1850	ML908	60	ML911	62
30 x 60	1850	ML909	71	ML912	73

8" FLAT-FREE CASTERS

Platform Dimensions"	Capacity lbs.	Smooth Deck Model No.	Wt. lbs.	Tread Plate Deck Model No.	Wt. lbs.
24 x 36	1100	ML913	54	ML916	55
24 x 48	1100	ML914	58	ML917	60
30 x 60	1100	ML915	69	ML918	71

10" FLAT-FREE CASTERS

Platform Dimensions"	Capacity lbs.	Smooth Deck Model No.	Wt. lbs.	Tread Plate Deck Model No.	Wt. lbs.
24 x 36	1200	ML919	58	ML922	59
24 x 48	1200	ML920	62	ML923	64
30 x 60	1200	ML921	73	ML924	75



ML901



ML910



ML916



ML922



ML925



ML931



ML940



Smooth Deck



Tread Plate Deck

8" MOLD-ON RUBBER CASTERS

Platform Dimensions"	Capacity lbs.	Smooth Deck Model No.	Wt. lbs.	Tread Plate Deck Model No.	Wt. lbs.
24 x 36	2000	ML925	64	ML928	65
24 x 48	2000	ML926	68	ML929	70
30 x 60	2000	ML927	79	ML930	71

6" POLYURETHANE CASTERS

Platform Dimensions"	Capacity lbs.	Smooth Deck Model No.	Wt. lbs.	Tread Plate Deck Model No.	Wt. lbs.
24 x 36	3400	ML931	48	ML934	49
24 x 48	3400	ML932	52	ML935	54
30 x 60	3400	ML933	63	ML936	65

8" POLYURETHANE CASTERS

Platform Dimensions"	Capacity lbs.	Smooth Deck Model No.	Wt. lbs.	Tread Plate Deck Model No.	Wt. lbs.
24 x 36	4000	ML937	53	ML940	54
24 x 48	4000	ML938	57	ML941	59
30 x 60	4000	ML939	68	ML942	70

MOVING SUPPLIES

POLYETHYLENE TARPAULINS

- Reinforced polypropylene rope sewn-in welded hems
- Heavy-duty rust resistant grommets every 3'
- Increased UV resistance for long life
- Water resistant coating
- Finished sizes may vary due to hem allowance

STANDARD-DUTY BLUE

- 8 x 8 weave density
- 100-micrometres thick (4 mil)

HEAVY-DUTY WHITE

- 10 x 10 weave density
- 150-micrometres thick (6 mil)
- 4-corner patches

INDUSTRIAL GREEN/SILVER

- 14 x 14 high density weave
- 225-micrometres thick (9 mil)
- 9" x 9" triple layered on four corners

SUPER HEAVY-DUTY SILVER

- 16 x 16 high density weave
- 300-micrometres thick (12 mil)
- 9" x 9" triple layered on four corners
- Silver side provides heat and UV light diversion

NI771

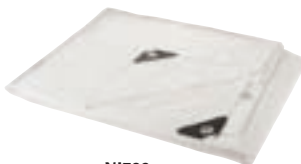
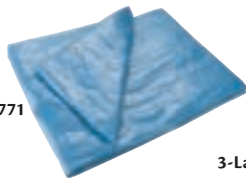

NI783
Heavy-Duty White



4 corner patches for added strength. (Heavy-duty white tarps only)

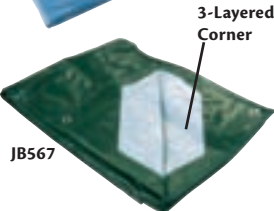

JB567

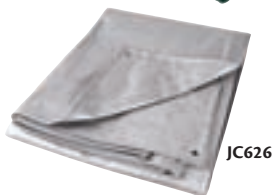

JC626



ND352



2" LOGISTIC STRAPS

- Designed to take care of most interior van loading requirements
- All Kinedyne® straps have a 4' fixed end as standard
- Adjustable ends are sewn captivated
- Comes with ratchet buckle and webbing
- Spring-loaded "E"

Model No.	Strap Length'	Width"	Breaking Strength lbs.	Colour	Working Load Limit lbs./kg
ND352	12	2	3000	Gold	1000/455
ND353	16	2	3000	Grey	1000/455
ND354	20	2	3000	Blue	1000/455

2" RATCHET STRAPS

- Designed to handle most types of flatbed tie-down requirements
- All straps have an 18" fixed end as standard and are labeled to meet CVSA guidelines



ND349

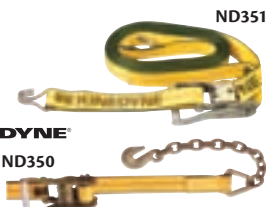

ND350

Model No.	Description	Strap Length'	Breaking Strength lbs.	Working Load Limit lbs./kg
ND349	Flat Hook	30	10 000	3335/1513
ND350	Chain Anchor	30	10 000	3335/1513
ND351	Wire Hook	30	10 000	1670/757

RUBBER TIE DOWNS

- Retains its rebound qualities
- Rot resistant
- Zinc-plated steel hooks

Model No.	Length"	Model No.	Length"
PE366	4	PE369	21
PE367	9	PE370	31
PE368	15	PE371	41



10-PC. BASIC TIE DOWN SET

Model No. PF090 Set contains: 4 PE369, 2 PE370 and 4 PE371

16-PC. ALL-PURPOSE TIE DOWN SET

Model No. PF091 Set contains: 2 PE367, 2 PE368, 4 PE369, 4 PE370 and 4 PE371

20-PC. PROFESSIONAL TIE DOWN SET

Model No. PF092 Set contains: 10 PE369 and 10 PE371



Dimensions'	Model No.			
	Standard-Duty Blue	Heavy-Duty White	Industrial Green/Silver	Super Heavy-Duty Silver
5 x 7	NI768	-	-	-
6 x 8	NI769	NI780	JB567	-
8 x 10	NI770	NI781	JB568	JC626
10 x 12	NI771	NI782	JB569	JC627
10 x 20	NI772	-	-	-
12 x 16	NI773	NI783	JB570	-
16 x 20	NI774	NI784	JB571	JC628
18 x 24	NI775	JC512	-	JC629
20 x 30	NI776	JC513	JB572	JC630
24 x 30	NI777	NI785	-	JC631
30 x 40	NI778	JC514	JC516	JC632
30 x 50	JC510	JC515	JC517	JC633
30 x 60	-	-	-	JC634
40 x 50	JC511	-	JC518	-
40 x 60	NI779	JB508	JB573	JC635

FURNITURE PADS

SUPREME FURNITURE PADS (PREMIUM)

- 40 oz. - 72" x 80" two tone
- Long lasting, premium pad is the finest and most luxurious
- Binding is double-stitched and bar-tacked for extra strength
- Thick 40-oz. filling
- Strong zigzag construction offers durability and ultimate protection
- Cotton/polyester blend sheeting

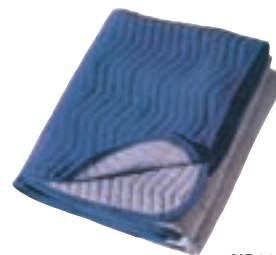

ND205

Model No.	Dimensions"	Colour	Wt. lbs.
ND205	72x80	Blue/Blue	5.33

ECONOMY FURNITURE PADS (STANDARD)

- 29 oz. - 72" x 80" two tone
- Cotton sheeting on one side, durable, non-woven polypropylene on other side



ND212

Model No.	Dimensions"	Colour	Wt. lbs.
ND212	72x80	Blue/Blue	4.83

SPACE SAVER PADS

- Lightweight, strong and durable
- 7 1/2 oz. burlap on one side and heavy, soft flannel on the other
- Zigzag stitching and wide, reinforced binding



ND214

Model No.	Dimensions"	Colour	Wt. lbs.
ND214	54x72	Blue/Brown	2.08

STRAP-ALL™ ONE INCH STRAPS

- Ratchet strap with ratchet
- Light-duty tie-down can be used on pick-up trucks, utility trailers, car top racks and boat trailers



Model No.	Strap Length'	Breaking Strength lbs.	Working Load Limit lbs.
ND361	16	1200	380

MACHINERY MOVERS & ROLLERS

LIGHT-DUTY SERIES ROLLERS

- Featuring an endless chain action design and comes in either rigid or swivel tops
- Both versions available topped with rough, rugged non-slip pads or smooth top style, ideal for permanent mounting applications
- Light duty series rollers are low and have high capacity



MA825

Model No.	Cap. Tons	Top Style	Dimensions			Wt. lbs.
			L"	W"	H"	
MA802	3/4	Swivel Padded	6 1/2	x 3 5/8	x 3 5/16	9
MA825	2	Swivel Padded	6 1/2	x 4 1/8	x 3 15/16	15
MD551	3/4	Swivel Smooth	6 1/2	x 3 5/8	x 3	9
MD552	2	Swivel Smooth	6 1/2	x 4 1/8	x 3 9/16	15
MA801	3/4	Rigid Padded	6 1/2	x 3 5/8	x 3	9
MA824	2	Rigid Padded	6 1/2	x 4 1/8	x 3 9/16	15

LIGHT-DUTY RIGGER KITS

3 TONS TO 8 TONS

- Kits contain two steering handles and four padded rollers offered with four swivel tops or two swivel and two rigid tops
- Sturdy steel carrying case stores all items and measures 16" L x 12 3/8" W x 4 3/8" D
- Handles knock down to fit in case



Model No.	Capacity Tons	Kit Contents	Wt. lbs.
MA879	3	4 x MA802 Swivel Top	55
MA875	3	2 x MA802 Swivel, 2 x MA801 Rigid Top	43
MA887	8	4 x MA825 Swivel Top	85
MA876	8	2 x MA825 Swivel, 2 x MA824 Rigid Top	83

TOE JACKS

- Strong, portable and safe
- Lifts loads with only 1" ground clearance
- 5 and 10-ton models operate horizontally and vertically
- Base, toe and pump assembly swivel independently of each other
- Perfect complement to any Hilman roller



Model No.	Max Lifting Height	Pick-Up Position At Base	Capacity Tons	Wt. lbs.
MH825	8.24	1.06	5	44
MH826	9.32	1.06	10	64
MH827	9.32	2.16	25	203

TRI-GLIDE 3-POINT MOVING SYSTEMS

6 TONS TO 18 TONS

- Tri-Glide 3-point moving system is designed for moving heavy loads over specially coated floors
- Comprised of a front steering unit and two rear adjustable units
- Additional modules can be added to further stabilize large, bulky loads
- Developed in response to a growing demand for floor protection when moving heavy loads over smooth, painted, finished, or sealed floors



DELUXE KITS

15 TONS TO 60 TONS

- Rugged kits are preferred by many professional riggers and movers
- Use them at the job site, in the factory, to solve your heavy load moving problems
- Steel chain-action rollers are perfect for machinery and equipment moves and convenient to have in every tool crib
- Kits include four locking rollers with either padded or diamond steel tops and two steering handles (four preload pads are included with diamond top kits)
- Kit cases are lockable and have sturdy lifting grips for easy handling



MA878



Model No.	Cap. Tons	Roll Material	Dimensions Front Unit			Rear Unit Width Adj."	Wt lbs.
			L"	W"	H"		
MH768	6	Nylon	21 1/16	x 18 1/2	x 4	10-48	186
MH769	12	Nylon	23 1/8	x 18 1/2	x 4	14-48	215
MH770	18	Nylon	25 5/8	x 18 1/2	x 4	19-48	24

BOLT-ON ROLLERS

- Oversized tops enable them to be bolted or welded to heavy load
- Work equally well upside down or right side up
- Ideal for applications requiring permanent or semi-permanent mounting (linear motion, bearing slides, heavy casters, or conveyors)



Model No.	Capacity Tons	Kit Contents	Wt. lbs.
MA878	15	4 x MA839 Padded Tops	196
MA877	15	4 x MA838 Diamonds, 4 x Preload Pad Tops	196
MA881	30	4 x MA863 Padded Tops	208
MA880	30	4 x MA862 Diamonds, 4 x Preload Pad Tops	208
MA883	40	4 x MA805 Padded Tops	212
MA882	40	4 x MA804 Diamonds, 4 x Preload Pad Tops	212
MA885	60	4 x MA812 Padded Tops	248
MA884	60	4 x MA811 Diamonds, 4 x Preload Pad Tops	252

Model No.	Capacity Tons	Dimensions			Wt. lbs.
		L"	W"	H"	
MA800	3/4	6 1/2	x 7	x 3 1/4	12
MA826	2 1/2	6 1/2	x 7	x 3 5/8	21
MA850	5	8	x 8	x 3 1/8	22
MA810	15	10 5/8	x 10	x 3 7/8	46
MA827	20	10 5/8	x 10	x 3 7/8	49
MA849	37 1/2	15	x 12	x 5 1/2	121
MA867	75	21	x 14	x 6 3/4	241

LIFT TABLES

HYDRAULIC SCISSOR LIFT TABLES

Kleton tables are available in various capacities and travels to satisfy a wide variety of applications. All models have an integrated hydraulic pump/cylinder assembly. The Kleton scissor lift tables add the value of mobility to the hydraulic lift table concept. Exceptional functionality and manoeuvrability is apparent, whether loaded or empty. In addition, rugged construction and premium-quality hydraulics complement their ease of use with low maintenance.

APPLICATIONS

Kleton tables are used in a wide variety of applications, from stocking shelves in retail stores to lifting and moving materials in warehouses, machine shops and manufacturing operations.

OPERATION

The Kleton design allows workers to easily move and position loads to a convenient working height. By minimising undesirable lifting, reaching and stretching, Kleton tables increase productivity and decrease workplace injuries.



STANDARD FEATURES

- Heavy-duty construction with captured scissor rollers for maximum stability
- Superior hydraulic systems feature an integrated pump-cylinder for maximum reliability
- High quality casters and wheels for exceptional roll ability (two fixed, two swivel)
- Ergonomic push handle with convenient lowering control
- Lowering control automatically stops when released for added safety
- Convenient maintenance pins secure the scissor legs for inspection and maintenance on larger models
- Quality powder coated finish provides exceptional durability and corrosion resistance
- Kleton blue

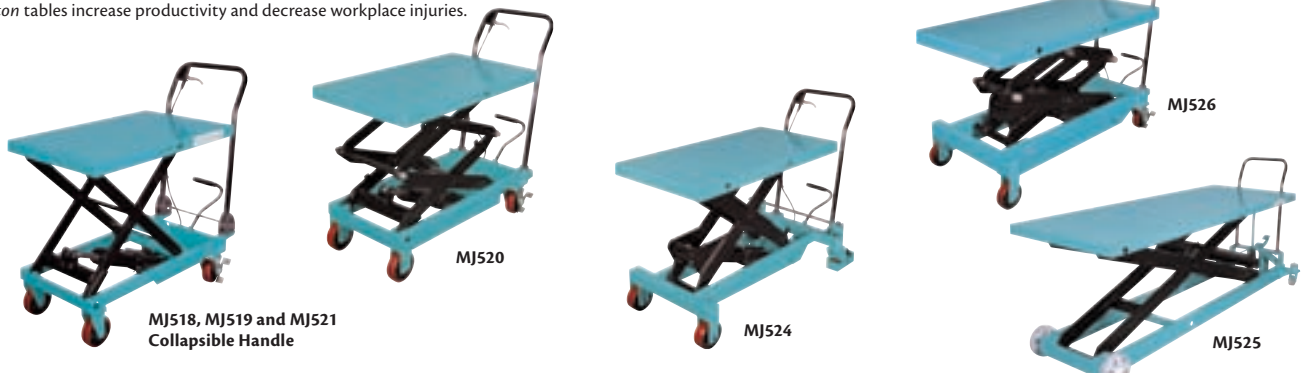

Model No.	Platform Height		Platform Dimensions		Handle Height"	Pedal Strokes To Max	Load Cap. lbs.	Wt. lbs.
	Lowered"	Raised"	Width"	Length"				
MJ518	8 5/8	29	17 3/4	27 1/2	37 3/8	28	330	99
MJ519	11 1/4	34 5/8	19 3/4	32	39	27	660	170
MJ520*	14	51 1/4	19 3/4	35 3/4	38 3/8	53	770	230
MJ521	11 1/4	34 5/8	19 3/4	32	39	27	1100	179
MJ522	11 1/4	36	31 7/8	63	39	55	1100	340
MJ523	16 1/2	35 3/8	20 1/8	39 3/8	39 3/8	45	1650	275
MJ524	15	39	20 1/8	40	38 5/8	82	2200	269
MJ525	11 3/4	55 1/8	29 1/2	80 1/8	39 3/8	200	2200	436
MJ526*	17 1/2	59 1/8	24	48	40	97	1760	430

*Double scissors

HYDRAULIC WORK TABLES

- All-welded construction
- Foot operated lifts are ideal for wide variety of shop functions (lifting dies, transporting heavy parts and positioning materials)
- Hand operated lever lowers the table level and controls the rate of descent
- Telescoping posts for stability and support
- Tops and bases are 3/16" thick steel
- Floor lock ensures table remains in place when loaded
- 4" x 2" bolted-on casters, two rigid and two swivel



Model No.	Table Height		Table Dimensions		Cap. lbs.	Wt. lbs.
	Lowered"	Raised"	Length" x	Width"		
MA433	28 1/2	46	16 x	16	200	54
MA434	30 1/2	47 1/2	18 x	18	500	122
MA435	30 1/2	47 1/2	18 x	36	1000	268
MA442	30 1/2	47 1/2	36 x	24	2000	225
MA443	30 1/2	47 1/2	48 x	32	2000	350

Other dimensions and capacities available

EZ LOADER PALLET LIFTERS

AUTOMATICALLY POSITIONS THE PALLET TO THE PROPER HEIGHT FOR ON OR OFF-LOADING.

- Minimizes bending and lifting and reduces extra movement around the pallet
- The Ez loader is weight sensitive: it raises and lowers the pallet as the load weight changes, keeping the top of the load at a convenient working height
- Rotating top minimizes walking or reaching during the loading process
- Allows on or off loading to be done from the near side and at a convenient height
- 3-position capacity, adjustable without changing air pressure
- Designed to work in conjunction with Bishamon's Unilift custom easy-to-read air gauge
- Air pressure capacity adjustment: 10-60 PSI
- Maximum internal air pressure: 135 PSI
- Shop air requirements: Clean dry air 60 PSI
- Heavy-duty, structural steel frame is 24 1/3" x 49" at base: turntable is 43" in diameter

* Inquire about stainless steel EZ loader pallet lifters

Model No. LT459



LIFT TABLES & SKID LIFTS

DANDY LIFT™

- Dandy Lift™ offers the ideal solution to reliable, economic lifting over years of service
- Pivot points have hardened pins in lifetime lubricated bearings
- Simple grouped controls make tables easy to operate
- Hard chrome-plated pistons and rods resist rust and corrosion for dependability and long life
- Honed heavy-walled cylinders improve both seal performance and durability

LOW PROFILE DANDY LIFT™

- Ideal for use in factories, warehouses and repair shops
- Fully lowered height of only 3 1/5"
- Platform fits easily under most skids and wire baskets
- Comes with two rigid and two swivel rubber casters
- Floor lock brake is standard



Built to last, all Dandy Lift™ tables are designed using heavy steel structural components.

SOUTHWORTH

Model No.	Platform		Platform Dim.			Overall Dim.			Foot pedal Strokes to Max.	Cap. lbs.	Wt. lbs.
	Lowered"	Raised"	L"	x	W"	L"	x	W"			
MA431	8 3/10	29	28	x	17 7/10	37 7/10	x	17 7/10	14	330	82
MA432	9 1/2	31 4/5	31 1/2	x	19 7/10	38 1/5	x	19 7/10	20	550	115
MA421	13 3/5	49 4/5	35 4/5	x	23 3/5	42 1/10	x	23 3/5	45	770	229
MA422	11 4/5	36 3/5	35 4/5	x	23 3/5	42 1/10	x	23 3/5	45	1100	194
MA423	13	40 1/5	39 2/5	x	23 3/5	45 9/10	x	23 3/5	56	1760	275
MA464*	3 1/5	29 1/2	37 1/10	x	19 7/10	55 2/5	x	19 7/10	15	1100	174

* Low profile

HYDRAULIC SKID LIFTS/TABLES

- Heavy gauge steel construction
- Transport and position skids, wire baskets and containers to comfortable working heights
- Adding optional slip-on table top creates a mobile, variable height work table
- Lifting range is from 3 1/4" to 32 3/4"
- 6" polyurethane swivel casters in the rear, 3" x 4" load wheels on legs
- Locking foot break
- Double roller chain lifts forks evenly and smoothly
- 2200-lb. capacity comes with an off-set steering wheel and control (pump) handle that elevates forks
- Lifting for 1000-lb. capacity is accomplished with a hydraulic foot pedal
- Approximately 50 strokes to reach maximum height
- Release knob on handle lowers forks
- 62" truck length
- Not designed for lifting double-sided pallets

Bishamon



OPTIONAL TABLES

Model No.	Fork Width"	Fork Length"	Capacity lbs.	Wt. lbs.
MK792	20 1/2	42 1/2	1000	300
MA445	20 1/2	42 1/2	2200	350
MK793	27	42 1/2	1000	325
MA447	27	42 1/2	2200	375

Model No.	Description	Wt. lbs.
MK794	Slip-On Table for MK792	35
MK796	Slip-On Table for MA445	35
MK795	Slip-On Table for MK793	44
MK797	Slip-On Table for MA447	44

SKID LIFTS

- Allows entry into different skids and baskets
- Lightweight design is easy to manoeuvre with pallet truck style steering configuration
- Strong and reliable cylinder
- Quick-lift mechanism on manual lifts allows loads under 400 lbs. to be raised with 24 strokes, heavier loads require 72 strokes
- Self-contained battery powered power pack (electric models) eliminates power source or power cord problems
- Built-in automatic battery charger and charge indicator (electric models)

- Raised bulkhead design provides greater backrest surface, ergonomic location for automatic battery charger and clear view of load
- 24" load centre
- Lowered height: 3 1/4", raised height: 31 1/2"
- 8" polyurethane load wheels and 3" polyurethane load roller
- Capacity: 3000 lbs.



LIFRITE

MANUAL LIFTS

Model No.	Frame Width"	Fork Length"	Wt. lbs.
MH748	20 1/2	48	330
MH749	27	48	340

ELECTRIC LIFTS

Model No.	Frame Width"	Fork Length"	Wt. lbs.
MH796	20 1/2	48	430
MH797	27	48	440

PLATFORM TRUCKS

STEEL DECK PLATFORM TRUCKS

Choose from a large selection of deck sizes and casters to suit any institutional and/or industrial application.

- Made of strong 14-gauge steel deck with a 2" folded bottom lip for extra strength
- Removable 1 1/4" tubular chrome handle can be inserted at either end of platform
- Two rigid and two swivel casters (assembly required, hardware is included)



CASTER WHEEL TYPES

Hi-Temp Nylon: Solid black nylon caster will not crush under heavy loads. Good for use on all types of surfaces from wood to concrete. Will tolerate temperatures from a low -28°C to a high of 230°C. Not affected by most corrosive chemicals.

Full Pneumatic: Air filled black rubber tire offers excellent shock absorbing properties. Smooth, quiet rolling over rough, uneven surfaces and outdoor terrain. Not recommended on floors with metal shavings or corrosive chemicals.

Mold-On Rubber: Molded rubber wheel bonded to a spoked cast iron core. The iron core gives it strength while the molded rubber provides easy, smooth and quiet rolling over rough terrain.

Non-Marking Rubber: Used for uneven surfaces and carpet areas. Its quiet rolling feature makes it ideal for both institutional and industrial applications. Will resist wet conditions and corrosive chemicals.

Polyolefin: Plastic wheel with high impact strength and non-chipping properties. Oil, grease and chemical resistant.



HEAVY-DUTY PLATFORM TRUCKS

WOOD DECK PLATFORM

- Sturdy 2" x 2" angle iron frame, with hardwood decking
- Ideal for carrying objects that scuff by metal to metal contact
- Steel frame absorbs shocks and handles uneven/heavy loads

ALL-STEEL PLATFORM

- Heavy 11-gauge, reinforced channel formed deck arc welded for maximum strength and long lasting rigidity
- Ideal for loads up to 2000 lbs.

CASTER PLACEMENT

- Available in standard-corner or diamond-tilt pattern
- Diamond tilt pattern allows the truck to tilt-balance slightly on the center side casters, allowing the truck to turn on its own length



Wood Deck



All Steel



Standard Corner Placement



Diamond Tilt Placement

CASTER SELECTION:

To select the correct caster that is required for a specific application determine:

- 1) Platform size needed
- 2) Maximum load capacity it will carry
- 3) Type of floor surface it will roll on i.e., concrete, wood, tile etc...
- 4) Floor condition i.e., smooth, uneven, wet, chemicals, metal shavings, temperature etc.

Model No.	Wheel Dia."	Wheel Type	Load Capacity/lbs.	Wt. lbs.
24" W X 36" L PLATFORM TRUCKS				
MB232	6	Hi-Temp Nylon	900	77
MB233	8	Hi-Temp Nylon	1000	87
MB234	8	Pneumatic	800	79
MB235	6	Mold-On Rubber	900	88
MB236	8	Mold-On Rubber	1000	96
MB237	5	Non-Marking Rubber	1000	63
MB238	5	Polyolefin	900	61
24" W X 48" L PLATFORM TRUCKS				
MB240	6	Hi-Temp Nylon	900	90
MB241	8	Hi-Temp Nylon	1000	100
MB242	8	Pneumatic	800	92
MB243	6	Mold-On Rubber	900	101
MB244	8	Mold-On Rubber	1000	109
MB245	5	Non-Marking Rubber	1000	76
MB246	5	Polyolefin	900	74
30" W X 48" L PLATFORM TRUCKS				
MD421	6	Hi-Temp Nylon	900	96
MD422	8	Hi-Temp Nylon	1000	106
MD423	8	Pneumatic	800	98
MD424	6	Mold-On Rubber	900	107
MD425	8	Mold-On Rubber	1000	115
MD426	5	Non-Marking Rubber	1000	82
MD427	5	Polyolefin	900	80
30" W X 60" L PLATFORM TRUCKS				
MB248	6	Hi-Temp Nylon	900	110
MB249	8	Hi-Temp Nylon	1000	120
MB250	8	Pneumatic	800	112
MB251	6	Mold-On Rubber	900	121
MB252	8	Mold-On Rubber	1000	129
MB253	5	Non-Marking Rubber	1000	96
MB254	5	Polyolefin	900	94

1000 lbs. Cap. Model No.	8" Rubber Wheels 1800 lbs. Cap. Model No.	8" Hi-Temp Nylon Wheels 2000 lbs. Cap. Model No.	Platform Dimensions* W" x L"	Wt. lbs.
WOOD DECK				
MB256	MB296	MB130	24 x 48-C	115
MB258	MB298	MB133	24 x 48-T	120
MB264	MB304	MB138	30 x 48-C	135
MB266	MB306	MB141	30 x 48-T	140
MB267	MB308	MB142	30 x 60-C	145
MB270	MD332	MB145	30 x 60-T	150
MB279	MB320	MB155	36 x 72-C	180
MB282	MB322	MB157	36 x 72-T	190
MB284	MB324	MB166	48 x 96-C	280
MB286	MB326	MB169	48 x 96-T	300
STEEL DECK				
MB255	MB295	MB131	24 x 48-C	110
MB257	MB297	MB132	24 x 48-T	115
MB263	MB303	MB139	30 x 48-C	130
MB265	MD331	MB140	30 x 48-T	135
MB268	MB307	MB143	30 x 60-C	140
MB269	MB309	MB144	30 x 60-T	145
MB280	MB319	MB154	36 x 72-C	175
MB281	MB321	MB156	36 x 72-T	185
MB283	MB323	MB167	48 x 96-C	240
MB285	MB325	MB168	48 x 96-T	265

* Suffix C after platform size signifies corner caster placement. T is diamond tilt.



CUSTOMISE IT TO YOUR SPECIFICATIONS.
SEE PAGE B60 FOR DETAILS

PLATFORM TRUCKS

HEAVY-DUTY PLATFORM TRUCKS

- Solid 7/8" hardwood deck with 5" x 1 5/8" hardwood sidewall
- Easy to manoeuvre with 44" high handle
- 15" deck height
- Two 12" hi-temp nylon load wheels and two 6" swivel casters
- Capacity: 3000 lbs.

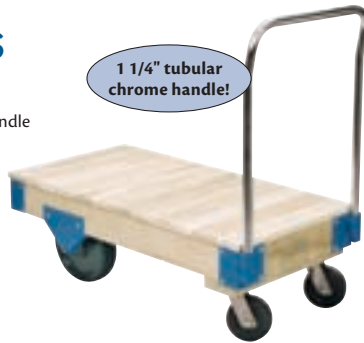

Model No.	Platform Dimensions			Wt. lbs.
	W"	x	L"	
MB122	24	x	48	150
MB123	30	x	48	170
MB124	30	x	60	195
MB125	36	x	60	210
MB126	36	x	72	230

WAGON TRUCKS

- Fifth wheel steering makes these trucks easy to manoeuvre under full loads
- 14 1/4" deck height
- 10" pneumatic wheels
- Capacity: 1000 lbs.
- Durable Kleton blue enamel finish



Wood Deck Model No.	Wt. lbs.	Steel Deck Model No.	Wt. lbs.	Platform Dim.	
				W"	x L"
MD186	120	MD187	130	24	x 48
MD188	150	MD189	170	30	x 60
MD192	190	MD193	210	36	x 72

TRIPLE™ TROLLEYS

- Three-position handle lets users push, pull or fold flat for space efficient storage
- Non-skid surface helps prevent load shifting
- Durable, structural foam deck will not rust, dent or bend
- Mark resistant casters provide stability over rough surfaces



Model No.	Dimensions			Cap. lbs.	Wt. lbs.
	W"	x	L"		
MH708	20 1/2	x	32 1/2	500	25

ERGONOMIC PLATFORM TRUCKS

- Ergonomic handle is placed at a comfortable working height to alleviate back strains
- Picking list holder eliminates the need to handle loose papers
- Deck is constructed from 14-gauge all welded steel with a turned down lip and reinforced channels
- Two rigid and two swivel 8" mold-on rubber casters
- 48" L x 24" W
- Capacity: 1000 lbs.
- Kleton powder coat finish

Model No. ML892



HEAVY-DUTY PLATFORM TRUCKS

- Ideal for moving large and heavy loads
- Ergonomic handle design improves control and worker safety
- Powder-coated steel handle with retainer clips prevents unintended removal
- Steel reinforced deck for enhanced durability
- Molded-in-tie-down slots for load security
- Textured deck for enhanced durability
- Perimeter deck channel retains small items
- Two rigid and two swivel casters
- Assembly required



Model No.	Overall Dimensions			Caster Type	Capacity lbs.	Wt. lbs.	
	W"	x	L"				
ML565	24	x	40 1/4	39 3/4	6" Rubber	1000	58
ML566	24	x	40 1/4	39 3/4	6" Polyolefin	2000	63
ML567	24	x	52 1/4	41 3/4	8" Rubber	2000	76
ML568	24	x	52 1/4	41 3/4	8" Pneumatic	1200	76
ML569	24	x	52 1/4	41 3/4	8" Polyolefin	2500	80
ML570	30	x	64 1/4	41 5/8	8" Rubber	2000	87
ML571	30	x	64 1/4	41 5/8	8" Pneumatic	1200	87
ML572	30	x	64 1/4	41 5/8	8" Polyolefin	2500	100
ML573	40	x	70	37	6" Rubber	1000	127
ML574	40	x	70	39 1/8	8" Pneumatic	1000	127
ML575	40	x	70	39 1/8	8" Polyolefin	2000	127

5TH WHEEL WAGON TRUCKS

- Ideal for moving heavy loads in manufacturing plants, warehouses, maintenance shops and outdoor environments
- Fifth wheel steering ensures tight turning radius and easy manoeuvrability
- Vinyl grip, powder coated "T" handle stays upright when not in use
- "T" handle is removable for towing capabilities (tow package sold separately)
- Steel reinforced deck for enhanced durability
- Molded-in tie-down slots for load security
- Textured deck channel and perimeter deck channel retains small items



Model No.	Overall Dimensions			Caster Type	Capacity lbs.	Wt. lbs.	
	W"	x	L"				
ML585	24	x	42 7/8	29 3/4	10" Pneumatic	1200	60
ML586	24	x	42 7/8	29 3/4	10" Rubber	2000	60
ML587	24	x	54 7/8	31 3/4	12" Pneumatic	2000	71
ML588	24	x	54 7/8	31 3/4	12" Rubber	2000	71
ML589	30	x	66 7/8	31 3/4	12" Pneumatic	2000	88
ML590	30	x	66 7/8	31 3/4	12" Rubber	2000	88
ML591	40	x	70	48 5/8	12" Pneumatic	2000	125
ML592	40	x	70	50 3/4	16" Pneumatic	2000	130
ML593	Tow package			-	-	-	2.8

WAREHOUSE TRUCKS

INSTITUTIONAL PLATFORM TRUCKS

- Ideal truck for institutional applications - hospitals, restaurants, shopping centres, offices, industry and anywhere else a quiet ride and professional appearance is required
- 14-gauge steel deck with 2" lip underneath
- Non-skid rubber surface means product will not shift during use
- Rubber corner bumpers protect walls and furniture
- 1 1/4" tubular chrome handle with end panel contains small packages
- 5" non-marking rubber casters for a smooth, quiet ride; two rigid and two swivel
- Capacity: 1000 lbs
- Shipped knocked down

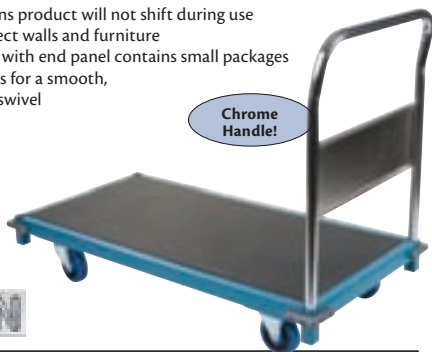

Model No.	Dimensions			Wt lbs.
	W"	x	L"	
MB190	24	x	36	64
MB208	24	x	48	70
MB207	30	x	48	88
MB209	30	x	60	100

FOLDING HANDLE PLATFORM TRUCKS

- Heavy gauge steel construction; non-skid vinyl coated deck
- Move supplies, forms and light equipment around the shop or office
- Quick-release handle folds flat for easy storage
- 33 1/2" handle height
- Vinyl, wrap around bumper protects walls and furniture
- Rubber casters



Model No.	Platform Dim.		Caster Dia."	Cap. lbs.	Wt. lbs.
	W"	x L"			
MK988	19	x 29	5	400	25
MK989	23	x 35	5	660	41

FOLDABLE PLATFORM TRUCKS

- Ideal when solid, portable platform truck is required
- Interlocking aluminum frame has dual length platform: 16" W x 20" L or 16" W x 28" L; handle height is 32"
- Standard with vinyl corner bumpers
- Folds down to a compact 16" W x 20" L x 9 1/2" H
- Rolls easily on 4" rubber casters
- Capacity: 300 lbs.
- Weight: 18 lbs.

Model No. MK990



SEMI-LIVE SKIDS

- Ideal for temporary storage of materials
- Heavy 11-gauge steel deck with reinforced channels or 3/16" x 2" x 2" angle frame with hardwood deck
- 52" jack handle (sold separately) quickly engages skid and turns it into a portable truck that manoeuvres easily in confined areas
- Skids and handle come with 8" mold-on rubber wheels
- Capacity: 1800 lbs.
- Durable Kleton blue enamel finish

MB348



MB327



MB328



Steel Deck Model No.	Wt. lbs.	Wood Deck Model No.	Wt. lbs.	Deck Height	Platform Dimensions W" x L"
MB327	110	MB328	115	12	24 x 48
MB329	130	MB330	135	12	30 x 48
MB331	140	MB332	145	12	30 x 60
MB337	175	MB338	180	12	36 x 72
MB348 Jack Handle			30		

DEAD SKIDS

- Tough and durable platforms for temporary storage and handling of material
- Heavy 11-gauge steel deck with reinforced channels
- 3/16" x 2" x 2" angle frame with hardwood deck
- Available with steel or hardwood decks
- Four sturdy steel legs keep loads off the floor
- Can be stacked when not in use
- Capacity: 2500 lbs.
- Durable Kleton blue enamel finish



ML071



ML072



Model No.	Deck Dim. W" x L"	Platform Type	Deck Height"	Wt. lbs.
ML071	24 x 48	Steel	6	110
ML072	24 x 48	Wood	6	115
ML073	30 x 48	Steel	6	130
ML074	30 x 48	Wood	6	135
ML075	30 x 60	Steel	6	140
ML076	30 x 60	Wood	6	145
ML077	36 x 72	Steel	6	175
ML078	36 x 72	Wood	6	180



CUSTOMISE IT TO YOUR SPECIFICATIONS.
SEE PAGE B60 FOR DETAILS

WIRE MESH STOCK CARTS

WIRE MESH UTILITY CARTS

- Rugged all-welded steel construction ready to use
- Designed for efficient loading/unloading and transportation of merchandise
- 14-gauge steel shelves, 1 1/2" lip up
- Frame constructed from 1 1/2" angle iron and 2" x 2" wire mesh
- **Includes:** Two rigid and two swivel 5" or 6" bolted-on casters
- Capacity: 1000-2000 lbs.
- Durable Kleton blue enamel finish

5" Non-Marking Rubber 1000-lb. Cap. Model No.	6" Polyurethane 2000-lb. Cap. Model No.	Base W" x L"	Inside Wall Height"	Handle Height"	Clearance Between Shelves"	Overall Dimensions W" x L" x H"	Wt. lbs.
TWO-SIDED, TWO SHELVES							
ML162	ML168	24 x 36	55	42	26	24 x 39 x 63	95
ML163	ML169	24 x 48	55	42	26	24 x 51 x 63	112
ML164	ML170	24 x 60	55	42	26	24 x 63 x 63	127
ML165	ML171	30 x 48	55	42	26	30 x 51 x 63	129
ML166	ML172	30 x 60	55	42	26	30 x 63 x 63	144
ML167	ML173	30 x 72	55	42	26	30 x 75 x 63	167
TWO-SIDED, THREE SHELVES							
ML174	ML180	24 x 36	55	42	16 1/2	24 x 39 x 63	120
ML175	ML181	24 x 48	55	42	16 1/2	24 x 51 x 63	137
ML176	ML182	24 x 60	55	42	16 1/2	24 x 63 x 63	152
ML177	ML183	30 x 48	55	42	16 1/2	30 x 51 x 63	154
ML178	ML184	30 x 60	55	42	16 1/2	30 x 63 x 63	169
ML179	ML185	30 x 72	55	42	16 1/2	30 x 75 x 63	192
THREE-SIDED, ONE SHELF							
ML220*	ML190*	24 x 36	55	42	-	24 x 39 x 63	102
ML221*	ML191*	24 x 48	55	42	-	24 x 51 x 63	110
ML222*	ML192*	24 x 60	55	42	-	24 x 63 x 63	120
ML223*	ML193*	30 x 48	55	42	-	30 x 51 x 63	135
ML224*	ML194*	30 x 60	55	42	-	30 x 63 x 63	145
ML225*	ML195*	30 x 72	55	42	-	30 x 75 x 63	155
THREE-SIDED, TWO SHELVES							
ML196	ML202	24 x 36	55	42	26	24 x 39 x 63	127
ML197	ML203	24 x 48	55	42	26	24 x 51 x 63	142
ML198	ML204	24 x 60	55	42	26	24 x 63 x 63	159
ML199	ML205	30 x 48	55	42	26	30 x 51 x 63	182
ML200	ML206	30 x 60	55	42	26	30 x 63 x 63	192
ML201	ML207	30 x 72	55	42	26	30 x 75 x 63	211
THREE-SIDED, THREE SHELVES							
ML208	ML214	24 x 36	55	42	16 1/2	24 x 39 x 63	152
ML209	ML215	24 x 48	55	42	16 1/2	24 x 51 x 63	174
ML210	ML216	24 x 60	55	42	16 1/2	24 x 63 x 63	198
ML211	ML217	30 x 48	55	42	16 1/2	30 x 51 x 63	229
ML212	ML218	30 x 60	55	42	16 1/2	30 x 63 x 63	239
ML213	ML219	30 x 72	55	42	16 1/2	30 x 75 x 63	267

* Base shelf only

SECURITY TRUCKS

- Rugged all-welded steel construction, ready to use
- Designed for efficient loading/unloading and transportation of merchandise
- 14-gauge steel shelves, 1 1/2" lip up
- Frame constructed from 1 1/2" angle iron and 2" x 2" wire mesh
- **Includes:** Two rigid and two swivel 5" or 6" bolted-on casters
- Comes with hasp for padlock
- Capacity: 1000-2000 lbs.
- Durable Kleton blue enamel finish

5" Non-Marking Rubber 1000-lb. Cap. Model No.	6" Polyurethane 2000-lb. Cap. Model No.	Base W" x L"	Inside Wall Height"	Handle Height"	Clearance Between Shelves"	Overall Dimensions W" x L" x H"	Wt. lbs.
TWO SHELVES							
ML238	ML244	24 x 36	55	42	25	24 x 39 x 62 1/2	157
ML239	ML245	24 x 48	55	42	25	24 x 51 x 62 1/2	172
ML241	ML247	30 x 48	55	42	25	30 x 51 x 62 1/2	212
ML242	ML248	30 x 60	55	42	25	30 x 63 x 62 1/2	222
ML243	ML249	30 x 72	55	42	25	30 x 75 x 62 1/2	241
THREE SHELVES							
ML250	ML256	24 x 36	55	42	16	24 x 39 x 62 1/2	182
ML251	ML257	24 x 48	55	42	16	24 x 51 x 62 1/2	204
ML253	ML259	30 x 48	55	42	16	30 x 51 x 62 1/2	259
ML254	ML260	30 x 60	55	42	16	30 x 63 x 62 1/2	269
ML255	ML261	30 x 72	55	42	16	30 x 75 x 62 1/2	297

BOX TRUCKS

- Rugged all-welded steel construction, ready to use
- Contain and transport small bulk parts or materials in your plant or warehouse
- Frame constructed from 1 1/2" angle iron construction and 2" x 2" wire mesh
- **Includes:** Two rigid and two swivel 5" non-marking bolted-on rubber casters
- Capacity: 1000 lbs.
- Durable Kleton blue enamel finish

Model No.	Base W" x L"	Inside Wall Height"	Handle Height"	Overall Dim. W" x L" x H"	Wt. lbs.
MB672	24 x 36	24	30	24 x 39 x 31 1/2	62
ML186	24 x 48	24	30	24 x 51 x 31 1/2	75
ML187	24 x 60	24	30	24 x 63 x 31 1/2	85

Model No.	Base W" x L"	Inside Wall Height"	Handle Height"	Overall Dim. W" x L" x H"	Wt. lbs.
ML188	30 x 48	24	30	30 x 51 x 31 1/2	86
MB680	30 x 60	24	30	30 x 63 x 31 1/2	95
ML189	30 x 72	24	30	30 x 75 x 31 1/2	107



ML163



ML200



ML254



CUSTOMISE IT TO YOUR SPECIFICATIONS. SEE PAGE B60 FOR DETAILS

WAREHOUSE TRUCKS & CARTS

FRAME SHEET/PANEL TRUCKS

- All-welded truck is ideal for handling long, flat, awkward loads
- Available with open or closed base
- Four bolted-on 5" non-marking rubber swivel casters
- Capacity: 1000 lbs.
- Durable *Kleton* blue enamel finish

MD217



ML064



Model No.	Base Type	Overall Dimensions			Wt. lbs.
		W"	L"	H"	
MD216	Open	24	x 36	x 48	50
ML063	Closed	24	x 36	x 48	60
MD217	Open	30	x 42	x 48	60
ML064	Closed	30	x 42	x 48	75
MD218	Open	36	x 72	x 48	85
ML065	Closed	36	x 72	x 48	110

REPLACEMENT CASTERS

ML337 5" Swivel Non-Marking Rubber Caster

DRYWALL CARTS

- All-welded multi-purpose cart is ideal for transporting drywall, wood or metal sheets
- 1 1/4" tubular rail handle and thick 11-gauge steel platform
- Two rigid and two swivel 8" bolted-on casters
- Deck dimensions: 15" W x 44" L x 14" H
- Overall dimensions: 24" W x 44" L x 44" H
- Durable *Kleton* blue enamel finish



MD214



Model No.	Caster Type	Deck Angle°	Cap. lbs.	Wt. lbs.
ML139	8" Mold-On Rubber	80	2000	115
MD214	8" Polyurethane	80	3500	110

LUMBER CARTS

- All-welded cart is ideal for transporting long and bulky items
- Welded 14-gauge 12" x 38" steel shelf
- Grey rubber bumpers protect walls and equipment
- Two rigid and two swivel bolted-on casters
- Capacity: 1000 lbs.
- Durable *Kleton* blue enamel finish



MB729



Model No.	Deck Dim.			Shelf Height"	Overall Dim.			Caster Type	Wt. lbs.
	W"	L"	H"		W"	L"	H"		
MB729	24	x 36	x 8	34	26	x 39	x 42	5" Rubber	80
ML140	24	x 36	x 10	36	26	x 39	x 45	6" Rubber	100

HIGH ENDS PLATFORM TRUCKS

- Tilt design allows truck to turn within its own radius
- 11-gauge steel deck is only 10" off the ground for easy loading
- Removable end racks constructed of 1 1/4" round steel tube
- Two 8" x 2" bolted-on rigid caster and four 5" swivel casters
- Capacity: 1500 lbs.
- Durable *Kleton* blue enamel finish

MK970



Model No.	Overall Dimensions			Wt. lbs.
	W"	L"	H"	
MK970	18	x 48	x 72	115
MK971	18	x 60	x 72	125

HEAVY-DUTY PANEL & LUMBER MOVER TRUCKS

- All-welded, ready to use
- Constructed from 1 1/4" round tubing and an 11-gauge deck
- Ideal for transporting large sheets and long parts
- Uprights extend 21" and 33" above deck
- Deck is 12" off the floor
- 8" clear space between tubes
- Two rigid and two swivel 8" casters
- Durable *Kleton* blue enamel finish



ML360



Model No.	Overall Dimensions			Caster Type	Cap. lbs.	Wt. lbs.
	W"	L"	H"			
ML360	30	x 48	x 45	Mold-On Rubber	2000	160
ML361	30	x 48	x 45	Polyurethane	2500	175
ML362	30	x 60	x 45	Mold-On Rubber	2000	160
ML363	30	x 60	x 45	Polyurethane	2500	175

SINGLE LEVEL RAILS HEAVY-DUTY PANEL MOVER TRUCKS

- All-welded truck ideal for transporting large sheets and long parts
- Construction from 1 1/4" round tubing and reinforced 11-gauge deck
- Uprights extend 33" above deck
- Deck is 12" off the floor
- Overall height is 45"
- 8" clear space between tubes
- Two rigid and two swivel 8" casters
- Durable *Kleton* blue enamel finish



ML549



Model No.	Overall Dimensions			Caster Type	Capacity lbs.	Wt. lbs.
	W"	L"	H"			
ML549	30	x 48	x 45	8" Mold-On Rubber	2000	139
ML550	30	x 48	x 45	8" Polyurethane	2500	139
ML551	30	x 60	x 45	8" Mold-On Rubber	2000	161
ML552	30	x 60	x 45	8" Polyurethane	2500	161



CUSTOMISE IT TO YOUR SPECIFICATIONS.
SEE PAGE B60 FOR DETAILS

COMMERCIAL DUTY SHELF CARTS

KNOCKED-DOWN SHELF CARTS

- 16-gauge steel shelves with 2 1/2" high lip
- 1 1/2" x 1 1/2" x 12-gauge formed steel posts
- 1 1/4" diameter tubular steel handle
- Top and middle shelves can be installed lip up or down
- Two rigid and two swivel bolted-on casters
- Easy-to-assemble shipped knocked-down design
- Capacity: 900 lbs. evenly distributed
- Durable Kleton blue powder coat finish



MB492



MB496

2-SHELF UTILITY CARTS

Model No.	Shelf Dim. W" x D"	Shelf Clearance"	Post Height"	Overall Height"	Wt. lbs.
5" BLUE ELASTIC RUBBER CASTERS					
MB492	18 x 30	25	30	36	43
MB493	24 x 36	25	30	36	54
MB494	24 x 48	25	30	36	69
5" POLYOLEFIN CASTERS					
MB482	18 x 30	25	30	36	42
MB483	24 x 36	25	30	36	53
MB484	24 x 48	25	30	36	68
8" PNEUMATIC CASTERS					
MB488	24 x 36	25	30	40	60
MB489	24 x 48	25	30	40	75

4-SHELF UTILITY CARTS

Model No.	Shelf Dim. W" x D"	Shelf Clearance"	Post Height"	Overall Height"	Wt. lbs.
5" BLUE ELASTIC RUBBER CASTERS					
ML145	18 x 30	10	42	48	66
ML146	24 x 36	10	42	48	85
ML147	24 x 48	10	42	48	115
ML148	18 x 30	15	55	61	68
ML149	24 x 36	15	55	61	87
ML150	24 x 48	15	55	61	117
5" POLYOLEFIN CASTERS					
MN148	18 x 30	10	42	48	65
MN149	24 x 36	10	42	48	84
MN150	24 x 48	10	42	48	114
MN151	18 x 30	15	55	61	67
MN152	24 x 36	15	55	61	86
MN153	24 x 48	15	55	61	116
8" PNEUMATIC CASTERS					
MN154	24 x 36	10	42	52	90
MN155	24 x 48	10	42	52	120
MN156	24 x 36	15	55	65	92
MN157	24 x 48	15	55	65	122

ERGONOMIC SHELF CARTS

- All-welded 16-gauge construction
- All-welded ergonomic handle placed at a comfortable working height
- Two rigid and two swivel 5" casters
- Capacity: 800 lbs.
- Durable Kleton blue enamel finish



Model No.	Number of Shelves	Caster Type	Overall Dimensions W" x D" x H"
ML561	2	Blue Rubber	20 x 32 x 37
MN056	2	Blue Rubber	26 x 38 x 37
ML562	3	Blue Rubber	20 x 32 x 37
MN055	3	Blue Rubber	26 x 38 x 37
ML563	2	Polyolefin	20 x 32 x 37
ML883	2	Polyolefin	26 x 38 x 37
ML564	3	Polyolefin	20 x 32 x 37
ML884	3	Polyolefin	26 x 38 x 37

3-SHELF UTILITY CARTS

Model No.	Shelf Dim. W" x D"	Shelf Clearance"	Post Height"	Overall Height"	Wt. lbs.
5" BLUE ELASTIC RUBBER CASTERS					
MB495	18 x 30	11	30	36	54
MB496	24 x 36	11	30	36	70
MB497	24 x 48	11	30	36	93
ML142	18 x 30	17	42	48	56
ML143	24 x 36	17	42	48	72
ML144	24 x 48	17	42	48	95
5" POLYOLEFIN CASTERS					
MB485	18 x 30	11	30	36	53
MB486	24 x 36	11	30	36	69
MB487	24 x 48	11	30	36	92
MN143	18 x 30	17	42	48	55
MN144	24 x 36	17	42	48	71
MN145	24 x 48	17	42	48	94
8" PNEUMATIC CASTERS					
MB490	24 x 36	11	30	40	77
MB491	24 x 48	11	30	40	100
MN146	24 x 36	17	42	52	79
MN147	24 x 48	17	42	52	102
5-SHELF UTILITY CARTS					
Model No.	Shelf Dim. W" x D"	Shelf Clearance"	Post Height"	Overall Height"	Wt. lbs.
5" BLUE ELASTIC RUBBER CASTERS					
ML151	18 x 30	10	55	61	80
ML152	24 x 36	10	55	61	100
ML153	24 x 48	10	55	61	135
5" POLYOLEFIN CASTERS					
MN158	18 x 30	10	55	61	79
MN159	24 x 36	10	55	61	99
MN160	24 x 48	10	55	61	134
8" PNEUMATIC CASTERS					
MN161	24 x 36	10	55	65	105
MN162	24 x 48	10	55	65	140



ML561



CUSTOMISE IT TO YOUR SPECIFICATIONS.
SEE PAGE B60 FOR DETAILS

COMMERCIAL DUTY SHELF CARTS

HEAVY-DUTY LOW PROFILE SHOP CARTS

- All-welded cart with low shelf means less distance to lift heavy objects
- Two 14-gauge steel shelves with a 1 1/2" lip down
- 1 1/4" diameter tubular steel handle
- Two rigid and two swivel bolted-on casters
- Durable *Kleton* blue enamel finish



5" RUBBER CASTERS

- Non-marking casters are quiet rolling and ideal for both institutional and industrial applications
- Casters are resistant to wet and corrosive chemical conditions
- Capacity: 1000 lbs.

Model No.	Shelf Dimensions W" x L"	Clearance Between Shelves"	Top Shelf Height"	O.A. Dim. W" x L" x H"	Wt. lbs.
MB421	18 x 30	16	26	18 x 34 x 40	90
MB425	24 x 36	16	26	24 x 40 x 40	110
MB429	24 x 48	16	26	24 x 52 x 40	125
ML097	24 x 60	16	26	24 x 64 x 40	155
ML098	30 x 48	16	26	30 x 52 x 40	155
MB434	30 x 60	16	26	30 x 64 x 40	165
ML099	30 x 72	16	26	30 x 76 x 40	175

6" HI-TEMP NYLON OR POLYURETHANE CASTERS

- Solid black hi-temp nylon casters handle heavy loads easily
- Solid polyurethane casters are non-marking and are highly resistant to wear
- Best choice in uneven floor applications
- Capacity: 2000 lbs.

6" Nylon Model No.	6" Polyurethane Model No.	Shelf Dim. W" x L"	Clearance Between Shelves"	Top Shelf Height"	O.A. Dim. W" x L" x H"	Wt. lbs.
MB422	ML103	18 x 30	16	27	18 x 34 x 41	100
MB426	ML104	24 x 36	16	27	24 x 40 x 41	130
MB430	ML105	24 x 48	16	27	24 x 52 x 41	145
ML100	ML106	24 x 60	16	27	24 x 64 x 41	155
ML101	ML107	30 x 48	16	27	30 x 52 x 41	155
MB435	ML108	30 x 60	16	27	30 x 64 x 41	165
ML102	ML109	30 x 72	16	27	30 x 76 x 41	175

STOCK PICKING CARTS

- All-welded design for durability and long life
- Pick and transport stock without the need for a separate ladder
- Slip-resistant steps and positive locking engagement for safety
- Step rise: 9 1/2"
- Three 14-gauge steel shelves with 1 1/2" lip, configured up
- Clearance between shelves: 12"
- Two rigid and two swivel bolted-on 5" non-marking rubber casters
- Capacity: 1000 lbs.
- Durable *Kleton* blue enamel finish



Model No.	Shelf Dim. W" x D"	Number of Steps	Step Dim. W" x D"	Overall Dimensions W" x D" x H"	Wt. lbs.
MD441	24 x 36	3	22 x 4	24 x 52 x 61	135
MB507	24 x 48	3	22 x 4	24 x 64 x 61	140
MD442	24 x 36	5	22 x 4	24 x 52 x 78	145
MB508	24 x 48	5	22 x 4	24 x 64 x 78	150

CUSTOMISE IT TO YOUR SPECIFICATIONS.
SEE PAGE B60 FOR DETAILS

SHELF/PLATFORM TRUCKS

- 2-in-1 shelf truck features removable top shelf and post assembly - converts into a platform truck when removed
- Standard features include: two front corner non-marking bumpers, four 5" non-marking rubber casters (two rigid and two swivel), two crossbars on push handle, all-welded heavy gauge steel assembly
- Shelf dimensions: 24" W x 36" L
- Capacity: 1000 lbs.
- Durable *Kleton* blue enamel finish



Model No.	O.A. Dim. W" x L" x H"	Top Shelf H"	Wt. lbs.
MB391	26 x 38 x 40	32	105

DEEP-LIPPED SERVICE CARTS

- All-welded design, ready-to-use
- Deep shelf lips for retention
- Two 14-gauge steel shelves welded to 1 1/2" x 1 1/2" x 1/8" steel posts
- 1" diameter tubular ergonomic handle
- Two rigid and two swivel 5" non-marking rubber casters
- Overall dimensions: 24" W x 42" D x 47" H
- Capacity: 1000 lbs.
- Durable *Kleton* blue enamel finish



Model No.	Shelf Dim. W" x D"	Shelf Lip Depth	Clearance Between Shelves	Wt. lbs.
MN393	24 x 36	Top 6"/Bottom 1 1/2"	22 1/2	85
MN394	24 x 36	Top 12"/Bottom 1 1/2"	16	90
MN395	24 x 36	Top 6"/Bottom 6"	18	90

MOBILE SERVICE CARTS

- All-welded design, ready-to-use
- Louvered panels for small parts bins and lockable drawer for supplies
- Two 14-gauge steel shelves welded to 1 1/2" x 1 1/2" x 1/8" steel posts
- 1" diameter tubular handle
- Two rigid and two swivel with brake bolted-on 5" non-marking rubber casters
- Overall dimensions: 24" W x 40" D x 57" H
- Capacity: 1000 lbs.
- Durable *Kleton* blue enamel finish



Model No.	Shelf Dim. W" x D"	Description	Clearance Between Shelves	Wt. lbs.
MN396	24 x 36	Top Lip Down/Bottom Lip Up	18	88

ELEVATED PLATFORM TRUCKS

- All-welded steel construction, ready-to-use
- 11-gauge steel deck with 2" square tube frames
- 1 1/4" round tube handle extends 14" above deck
- Removable handle
- Durable *Kleton* blue enamel finish



Model No.	Platform Dimensions W" x L"	Deck Height	Wheel Type	Capacity lbs.	Wt. lbs.
MN413	24 x 48	28	8" Hi-Temp Nylon	2000	140
MN414	30 x 60	28	8" Hi-Temp Nylon	2000	172
MN415	24 x 48	28	8" Mold-On Rubber	1800	140
MN416	30 x 60	28	8" Mold-On Rubber	1800	172
MN417	24 x 48	31	10" Pneumatic	1000	140
MN418	30 x 60	31	10" Pneumatic	1000	172

HEAVY-DUTY SHELF CARTS

HEAVY-DUTY SHELF CARTS

- All-welded design ready to use
- Cart constructed from 14-gauge steel shelves welded to 1 1/2" x 1 1/2" x 1/8" steel angle posts
- Versatile for all material transport
- 1" diameter tubular steel handle
- Shelves are available with a 1 1/2" lip configured up or down
- Two rigid and two swivel bolted-on 5" non-marking casters
- Capacity: 1000 lbs.
- Durable *Kleton* blue enamel finish



MB461



MB476

OVERALL HEIGHT: 36"

Lip Up Model No.	Lip Down Model No.	Shelf Dimensions			No. Shelves	Clearance Between Shelves"	Handle Height"	Overall Dimensions			Wt. lbs.
		W"	x	D"				W"	x	D" x H"	
MB445	MB444	18	x	30	2	27	36	18	x	33 x 36	60
MB447	MB446	24	x	36	2	27	36	24	x	39 x 36	65
MB449	MB448	24	x	48	2	27	36	24	x	51 x 36	100
MB456	MB455	18	x	30	3	12	36	18	x	33 x 36	75
MB459	MB458	24	x	36	3	12	36	24	x	39 x 36	85
MB461	MB460	24	x	48	3	12	36	24	x	51 x 36	110

OVERALL HEIGHT: 48"

Lip Up Model No.	Lip Down Model No.	Shelf Dimensions			No. Shelves	Clearance Between Shelves"	Handle Height"	Overall Dimensions			Wt. lbs.
		W"	x	D"				W"	x	D" x H"	
ML084	ML083	18	x	30	3	18	42	18	x	33 x 48	80
ML086	ML085	24	x	36	3	18	42	24	x	39 x 48	90
ML088	ML087	24	x	48	3	18	42	24	x	51 x 48	115
ML090	ML089	18	x	30	4	12	42	18	x	33 x 48	110
ML092	ML091	24	x	36	4	12	42	24	x	39 x 48	135
ML094	ML093	24	x	48	4	12	42	24	x	51 x 48	160

OVERALL HEIGHT: 61"

Lip Up Model No.	Lip Down Model No.	Shelf Dimensions			No. Shelves	Clearance Between Shelves"	Handle Height"	Overall Dimensions			Wt. lbs.
		W"	x	D"				W"	x	D" x H"	
MB468	MB467	18	x	30	4	16	42	18	x	33 x 61	115
MB470	MB469	24	x	36	4	16	42	24	x	39 x 61	140
MB472	MB471	24	x	48	4	16	42	24	x	51 x 61	165
MB474	MB473	18	x	30	5	11	42	18	x	33 x 61	125
MB476	MB475	24	x	36	5	11	42	24	x	39 x 61	155
MB478	MB477	24	x	48	5	11	42	24	x	51 x 61	184



ML092

HEAVY-DUTY SHELF CARTS WITH DRAWER

- All-welded design ready to use
- Carts constructed from 14-gauge steel shelves welded to 1 1/2" x 1 1/2" x 1/8" steel angle posts
- 1" diameter tubular steel handle
- Drawer dimensions: 15 1/4" W x 20" L x 6" H, 100-lb. capacity
- Available with two or three shelves with 1 1/2" lip configured up
- Two rigid and two swivel bolted-on 5" non-marking casters
- Capacity: 1000 lbs.
- Durable *Kleton* blue enamel finish



Model No.	Shelf Dimensions			Number of Shelves	Clearance Between Shelves"	Drawer to Shelf Clearance"	Handle Height"	Overall Dimensions			Wt. lbs.
	W"	x	D"					W"	x	D" x H"	
MH255	24	x	36	2	27	18	36	24	x	39 x 36	75
MH256	24	x	36	3	12	3	36	24	x	39 x 36	95



MH255

ORDER PICKING CARTS

- All-welded design for durability and long life
- Picking list holder eliminates the need to handle loose papers
- 14-gauge steel shelves with 1 1/2" lip, configured up
- Two rigid and two swivel bolted 5" non-marking rubber casters
- Capacity: 1000 lbs.
- Durable *Kleton* blue enamel finish



Model No.	Shelf Dimensions			No. Shelves	Between Shelves"	Handle Height"	Overall Dimensions			Wt. lbs.
	W"	x	D"				W"	x	D" x H"	
MB440	18	x	30	2	27	36	18	x	46 x 36	70
MB441	24	x	36	2	27	36	24	x	52 x 36	80
ML095	24	x	48	2	27	36	24	x	64 x 36	110
MB442	18	x	30	3	12	36	18	x	46 x 36	85
MB443	24	x	36	3	12	36	24	x	52 x 36	100
ML096	24	x	48	3	12	36	24	x	64 x 36	120



MB442



CUSTOMISE IT TO YOUR SPECIFICATIONS.
SEE PAGE B60 FOR DETAILS

SERVICE & UTILITY CARTS

PLASTIC FLAT SHELF UTILITY SERVICE CART

- Durable structural foam construction will not dent, rust or bend
- Non-marking 4" casters
- Flat top shelf makes loading and unloading of heavy boxes easy
- Overall dimensions: 25 1/2" W x 40 1/4" L x 32" H
- Capacity: 500 lbs.

Model No. ML620



PLASTIC UTILITY SERVICE CARTS

- Durable structural foam construction will not dent, rust or bend
- Non-marking 4" casters
- Capacity: 500 lbs



ML619



ML618



Model No.	Overall Dimensions				
	W"	x	L"	x	H"
ML618	17 1/2	x	34 1/4	x	32
ML619	25 3/4	x	40 1/4	x	32

LIGHT-DUTY UTILITY CARTS

- Durable plastic construction
- Comes with middle shelf and two convenient handles
- Shelves are flat with retaining beaded edges
- Platinum



Model No.	Shelf Dimensions				Capacity lbs.	Wt. lbs.	
	W"	x	L"	x			H"
MH223	19	x	34	x	38	200	30
CART W/ENCLOSED END PANELS							
MH829	18	x	31	x	37 1/2	300	37



MH223

STANDARD/MEDIUM DUTY STAINLESS STEEL CARTS

- Durable chassis frame with protective bumpers on legs and handle
- Ideal for constant usage with light to moderate loads
- 1" edge on three sides of top and middle shelves
- All edges down on bottom shelf
- All rubber swivel casters standard



Model No.	Shelf Dimensions			No. of Shelves	Overall Dimensions			Caster Dim."	Cap. lbs.	Wt. lbs.
	W"	x	L"		W"	x	L"			
MI812	15 1/2	x	24	3	16 1/4	x	27 1/2	x	32 1/8	29
MI813	18	x	27	3	18 3/8	x	30 3/4	x	33	32
MI816	15 1/2	x	24	3	16 3/4	x	27 5/8	x	32 1/8	39
MI817	18	x	27	3	19	x	31	x	32 1/8	42
MI818	21	x	35	3	22 3/8	x	39 1/4	x	37 1/4	68



MI813

TRADES CARTS

- Use as mobile workbench
- Sized to hold large tools and supplies yet fits in tight spaces
- Four compartmentalized parts box and two versatile storage bins
- Mounting bracket to serve as an electrical cord wrap and convenient handle bin to keep small tools/parts
- Constructed of black plastic for lightness and durability
- 6" casters (two with brakes)
- Also available with a fully enclosed, lockable storage compartment
- 19 1/4" W x 38" L x 33 3/8" H
- Capacity: 180 lbs. (top shelf), 150 lbs. (bottom shelf)
- Assembly required

Model No. MK744

Trades Cart Wt.: 50 lbs.

Model No. MK745

Trades Cart w/Lockable Cabinet Wt.: 68 lbs



MK744



MK745



FLAT SHELF UTILITY CARTS

- Ergonomic handle design improves control and worker safety
- Flat design makes loading and unloading of heavy boxes and parts easier
- Easy to reach tool/accessory hooks and storage area enhances productivity and organization
- Top shelf perimeter channel retains small items
- Constructed from sturdy structural foam that will not rust, dent, chip nor splinter
- Two rigid and two swivel 5" non-marking TPR casters
- Assembly required



Model No.	Beige	Dimensions			Capacity lbs.	Wt. lbs.		
		W"	x	L"			x	H"
ML456	ML457	19	x	37 7/8	x	33 1/4	500	33
ML458	ML459	25 7/8	x	43 7/8	x	33 1/4	500	42
ML460	ML461	25 1/4	x	54	x	38	750	52



ML456

HEAVY-DUTY UTILITY CARTS

- Ergonomic handle design improves control and worker safety
- Easy to reach tool/accessory hooks and storage area enhances productivity and organization
- 2 3/4" deep top shelf securely holds contents
- Constructed from sturdy structural foam that will not rust, dent, chip nor splinter
- Two rigid and two swivel casters
- Assembly required



Model No.	Caster Type	Dimensions			Capacity lbs.	Wt. lbs.			
		W"	x	L"			x	H"	
ML448	ML449	5" Non-Marking TPR	17 7/8	x	39	x	33 1/4	500	31
ML450	ML451	5" Non-Marking TPR	25 7/8	x	45 1/4	x	33 1/4	500	44
ML452	-	8" Pneumatic	25 7/8	x	45 1/4	x	37 1/8	500	66
ML453	-	5" Non-Marking TPR	26	x	55	x	33 1/4	750	52
ML455	-	8" Pneumatic	26	x	55	x	33 1/4	750	74



ML448

GENERAL USE CASTERS

POLYOLEFIN CASTERS

- Rolls easily and quietly on all floors
- Lightweight and economical
- Non-marking, easy to maintain, steam cleanable
- High impact strength
- Superior resistance to most oils, chemicals, grease and acids

Applications:

For food service equipment, mobile warehouse equipment, factories and abusive environments.

Plate dimensions: 2 5/8" x 3 3/4"
Bolt hole centres: 1 3/4" x 2 7/8"
Bolt hole dimension: 5/16"



ML391



Model No.	Wheel Dia."	Caster Type	Capacity lbs.	Tread Width"	Overall Height"
ML391	3	Swivel	250	1 1/4	4 1/2
ML392	3	Rigid	250	1 1/4	4 1/2
ML393	4	Swivel	250	1 1/4	5 1/4
ML394	4	Rigid	250	1 1/4	5 1/4
ML395	5	Swivel	250	1 1/4	6 1/8
ML396	5	Rigid	250	1 1/4	6 1/8

POLYURETHANE CASTERS

- Smooth rolling, low noise operation
- Non-marking, cut and tear resistant
- Die cast aluminum core with brown polyurethane tread
- Resistant to most chemicals, moisture friendly
- Double ball raceway
- Annular ball bearing
- Brake type: Total locking

Applications:

Food service equipment, factory use, mobile warehouse equipment.

Plate dimensions:	Bolt hole centres:	Bolt hole dimension:
3 = 2 5/8" x 3 3/4"	3 = 1 3/4" x 2 3/4"	3 = 5/16"
4 = 3 1/8" x 4 1/8"	4 = 2 3/8" x 3 1/16"	4 = 5/16"
4 HD = 4" x 4 1/2"	4 HD = 3 1/4" x 2 3/4"	4 HD = 3/8"
5 = 4" x 4 1/2"	5 = 3 1/4" x 2 3/4"	5 = 3/8"
6 = 4" x 4 1/2"	6 = 3 1/4" x 2 3/4"	6 = 3/8"
8 = 4" x 4 1/2"	8 = 3 1/4" x 2 3/4"	8 = 3/8"



ML045

ML441

BLUE ELASTIC RUBBER CASTERS

- High load capacity, rolls easily and quietly on all floors
- Non-marking, excellent floor protection
- Zinc-chromed plated finish provides corrosion resistance
- Elastic rubber tread rejects floor debris
- Sealed double ball raceway
- Tread guards
- Ball bearing
- Brake type: Total locking

Applications:

General duty applications in mobile warehouse equipment and factory use.

Plate dimensions: 3 3/8" x 4"
Bolt hole centres: 2 3/8" x 3 1/8"
Bolt hole dimension: 5/16"



ML333



Model No.	Wheel Dia."	Caster Type	Capacity lbs.	Tread Width"	Overall Height"
ML333	4	Swivel	350	1 3/8	5
ML334	4	Rigid	350	1 3/8	5
ML342	4	Swivel w/Brake	350	1 3/8	5
ML337	5	Swivel	400	1 3/8	6
ML338	5	Rigid	400	1 3/8	6
ML345	5	Swivel w/Brake	400	1 3/8	6

Model No.	Wheel Dia."	Caster Type	Capacity lbs.	Tread Width"	Overall Height"
ML044	3	Swivel	230	1 1/4	4 1/4
ML043	3	Rigid	230	1 1/4	4 1/4
ML045	4	Swivel	440	1 1/2	5 3/8
ML046	4	Rigid	440	1 1/2	5 3/8
ML441	4HD	Swivel	550	1 5/8	5 5/8
ML442	4HD	Rigid	550	1 5/8	5 5/8
MN264	4HD	Swivel w/Brake	550	1 5/8	5 5/8
ML397	5	Swivel	650	1 1/2	6 1/2
ML398	5	Rigid	650	1 1/2	6 1/2
MN265	5	Swivel w/Brake	650	1 1/2	6 1/2
ML399	6	Swivel	850	1 1/2	7 1/2
ML400	6	Rigid	850	1 1/2	7 1/2
MN266	6	Swivel w/Brake	850	1 1/2	7 1/2
ML401	8	Swivel	1000	1 5/8	9 1/2
ML402	8	Rigid	1000	1 5/8	9 1/2
MN267	8	Swivel w/Brake	1000	1 5/8	9 1/2



MOLD-ON RUBBER CASTERS

- Molded rubber wheel permanently bonded to spoked cast iron core
- Iron centre gives it strength while the molded rubber offers smooth and quiet operation
- Protects loads and surfaces
- Won't damage warehouse or factory floors
- Brake type: Total locking

Surface Applications:

Concrete, brick, carpet, steel, tile, asphalt, wood and linoleum

Plate dimensions: 4" x 4 1/2"
Bolt hole centres: 2 7/8" x 3 1/3"
Bolt hole dimension: 7/16"



ML851



Model No.	Wheel Dia."	Caster Type	Capacity lbs.	Tread Width"	Bearing Type
ML846	5	Swivel	400	2	Roller
ML847	5	Rigid	400	2	Roller
ML849	6	Swivel	500	2	Roller
ML850	6	Rigid	500	2	Roller
ML851	6	Swivel w/Brake	500	2	Roller
ML852	8	Swivel	600	2	Roller
ML853	8	Rigid	600	2	Roller
ML854	8	Swivel w/Brake	600	2	Roller

HI-TEMP NYLON CASTERS

- Smooth rolling, non-marking
- Zinc chrome plated finish provides corrosion resistance
- Superior resistance to most oils, chemicals, and grease
- Double ball raceway
- Ball bearing
- Total lock brake
- Maximum temperature 230°C

Surface Applications:

Concrete, brick, carpet and steel

Plate dimensions: 4" x 4 1/2"
Bolt hole centres: 3" x 3 1/3"
Bolt hole dimension: 7/16"



ML863



Model No.	Wheel Dia."	Caster Type	Capacity lbs.	Tread Width"	Overall Height"
ML861	6	Swivel	800	1 3/4	7 5/8
ML862	6	Rigid	800	1 3/4	7 5/8
ML863	6	Swivel w/Brake	800	1 3/4	7 5/8
ML864	8	Swivel	850	1 3/4	9 1/2
ML865	8	Rigid	850	1 3/4	9 1/2
ML866	8	Swivel w/Brake	850	1 3/4	9 1/2

CASTERS

NYLON SANDWICH CASTERS

- Non-marking white nylon elastic rubber
- Cushion ring layer reduces noise and vibration
- Chrome zinc-finish for corrosion resistance
- Double raceway
- Ball bearing
- Brake type: Total locking



ML869

Surface Applications:

Concrete, brick, carpet and steel

Plate dimensions: 3 1/3" x 4 1/8"
Bolt hole centres: 3 1/8" x 2 1/3"
Bolt hole dimension: 5/16"



Model No.	Wheel Dia."	Caster Type	Capacity lbs.	Swivel Radius"	Tread Width"	Overall Height"
ML867	4	Swivel	440	3 4/5	1 3/8	5 1/8
ML868	4	Rigid	440	3 4/5	1 3/8	5 1/8
ML869	4	Swivel w/Brake	440	3 4/5	1 3/8	5 1/8
ML870	5	Swivel	500	3 4/5	1 3/8	6 1/8
ML871	5	Rigid	500	3 4/5	1 3/8	6 1/8
ML872	5	Swivel w/Brake	500	3 4/5	1 3/8	6 1/8

PNEUMATIC CASTERS

- Four ply pneumatic casters offer smooth and quiet rolling over the roughest surfaces and outdoor terrain
- Shock absorbing properties give the greatest possible protection to both the load and floor
- The "Air cushion" feature will transport the most fragile material and instruments without damage
- Not recommended for floors with metal shavings or corrosive chemicals

Surface Applications:

Concrete, brick, carpet, steel, tile, asphalt, wood and linoleum

Plate dimensions: 4" x 4 1/2"
Bolt hole centres: 2 3/4" x 3 3/8"
Bolt hole dimension: 13/32"



MN221

MN222



Model No.	Wheel Dia."	Caster Type	Capacity lbs.	Tread Width"	Overall Height"
MN222	8	Swivel	350	2	10
MN221	8	Rigid	350	2	10
MN224	10	Swivel	400	3	12
MN223	10	Rigid	400	3	12

For optimum use pneumatic wheels must be properly inflated

ENVIROTHANE™ WHEELS

- Solid non-marking polyurethane used for high load capacities
- Harder than soft rubber and softer than hard rubber
- Top quality wheel that will not damage your floors and will not develop flat spots under standing loads
- Government approved
- Temperature: -43°C to 110°C
- Durometer: 45 - 65 D Scale

Excellent for:

- Platform trucks
- Food service equipment
- Hotel equipment
- Small waste bins
- Large stock trucks
- Factory use
- Textile carts
- Abusive applications



Model No.	Wheel Dia."	Bearing Type	Cap. lbs.	Tread Width"	Hub Length"	Bearing Bore"
MG534	3	Nylon/Steel	100	7/8	1	5/16
MG535	3	Nylon	150	1	1 3/8	5/16
MG536	3	Nylon	250	1 1/4	1 5/8	5/16
MG537	4	Nylon	150	1	1 3/8	5/16
MG538	4	Nylon	250	1 1/4	1 5/8	5/16
MG539	4	Plain	500	1 1/2	1 3/4	3/8
MG540	4	Roller	650	2	2 3/16	1/2

THERMOPLASTIC CASTERS

- Heavy-duty double swivel raceway
- Grey thermoplastic rubber is non-marking and includes synthetic tread guards to protect roller bearings
- Durable zinc-plated pressed steel assembly for durability



ML017

Plate dimensions: 3 1/2" x 2 1/2"
Bolt hole centres: 2 3/4" x 1 3/4" centre-to-centre
Bolt hole dimension: 5/16"

Model No.	Wheel Dia."	Caster Type	Capacity lbs.	Tread Width"	Overall Height"	Bearing Type
ML014	3 1/8	Swivel	130	1 1/4	4 1/4	Ball
ML020	3 1/8	Rigid	130	1 1/4	4 1/4	Ball
ML017	3 1/8	Swivel w/Brake	130	1 1/4	4 1/4	Ball
ML015	4	Swivel	200	1 1/8	5 1/4	Ball
ML021	4	Rigid	200	1 1/8	5 1/4	Ball
ML018	4	Swivel w/Brake	200	1 1/8	5 1/4	Ball
ML016	5	Swivel	220	1 1/8	6 1/4	Ball
ML022	5	Rigid	220	1 1/8	6 1/4	Ball
ML019	5	Swivel w/Brake	220	1 1/8	6 1/4	Ball

FLAT-FREE CASTERS

- Solid polyurethane wheel never runs flat
- Same bounce feel and weight of a pneumatic caster
- Smooth and quiet rolling over rough terrain and surfaces
- Less costly than traditional foam-filled tires
- Ball bearing

Surface Applications:

Concrete, brick, carpet, steel, tile, asphalt, wood and linoleum

Plate dimensions: 4" x 4 1/2"
Bolt hole centres: 2 3/4" x 3 3/8"
Bolt hole dimension: 13/32"



MN226

MN225



Model No.	Wheel Dia."	Caster Type	Capacity lbs.	Tread Width"	Overall Height"
MN226	8	Swivel	275	2	10
MN225	8	Rigid	275	2	10
MN228	10	Swivel	300	3	12
MN227	10	Rigid	300	3	12

WHEELS

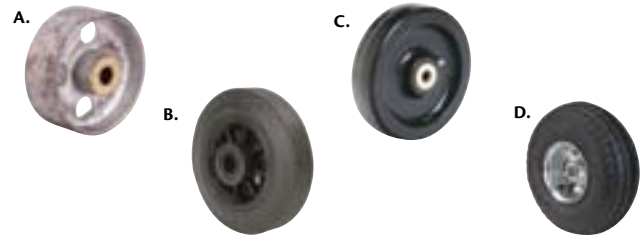

Model No.	Wheel Dia."	Bearing Type	Cap. lbs.	Tread Width"	Bearing Bore"	Wheel Type
A. MC298	5	Roller	1500	2	3/4	Cast Iron
B. MH296	6	Roller	400	1 1/2	3/4	Rubber
B. MH297	8	Roller	595	2	3/4	Rubber
B. MH298	10	Roller	400	2	3/4	Rubber
C. MC337	8	Roller	1000	2	3/4	Phenolic
C. MC340	12	Roller	3000	2 1/2	1	Phenolic
D. ML069	10	Ball	350	3 1/2	3/4	Pneumatic

MODULAR CABLE & HOSE PROTECTION SYSTEMS

Benefits:

- Weather and abrasion resistant; high load-bearing capacity
- Insulates electrical cables from human contact
- Makes length-of-run calculations easy
- Increases traction
- Lightweight; easy to transport, set-up, breakdown, and store; multi-length applications
- Allows for moving with ease
- High visibility

Features:

- Polyurethane construction, non-conductive material
- 36" length per lineal protector
- Five bar tread plate surface
- Safety warning symbols molded into protector
- Modular interlocking design
- Recessed carrying handle
- Universal safety colours

EXTRA HEAVY-DUTY 2, 3, 4, 5 CHANNEL SYSTEMS

For heavy trucks and forklifts in industrial environments.
Colour: Yellow lid/Orange base.

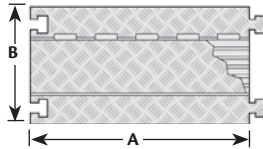

Female end cap

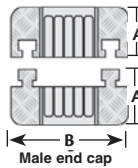

Male end cap



Model No.	Description	A Length"	B Width"	C Height"	D Channel Width"	E Channel Height"	Max Load Lbs. Per Tire	Wt. lbs.
KH687	5 Channel Protector	36	20	2 5/16	1 1/4	1 1/4	20 150	25
KH688	5 Channel End Caps (Female)	7 1/2	20	2 5/16	1 1/4	1 1/4		3.5
	5 Channel End Caps (Male)	5 1/4	20	2 5/16	1 1/4	1 1/4		3.5
KH691	4 Channel Protector	36	20	2 5/16	1 5/8	1 1/4	20 150	26
KH692	4 Channel End Caps (Female)	7 1/2	20	2 5/16	1 5/8	1 1/4		3.5
	4 Channel End Caps (Male)	5 1/4	20	2 5/16	1 5/8	1 1/4		3.5
KH695	3 Channel Protector	36	20	3 1/16	2 1/4	2 1/4	14 210	28
KH696	3 Channel End Caps (Female)	8 1/4	20	3 1/16	2 1/4	2 1/4		4
	3 Channel End Caps (Male)	6	20	3 1/16	2 1/4	2 1/4		4
KH699	2 Channel End Protector	36	22	4 1/8	3 1/4	3 1/4	10 880	33

HEAVY-DUTY GENERAL PURPOSE CHANNEL SYSTEMS

For vehicle and pedestrian traffic. Protects cable and hose lines up to 1 1/4" outside diameter.
Colour: Orange lid/Yellow base.

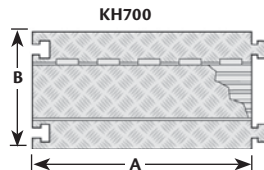

Female end cap

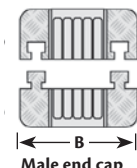

Male end cap



Model No.	Description	A Length"	B Width"	C Height"	D Channel Width"	E Channel Height"	Max Load Lbs. Per Tire	Wt. lbs.
KH700	5 Channel Protector	36	17 1/4	1 15/16	1 5/16	1 5/16	10 500	22
KH701	5 Channel End Caps (Female)	4 3/4	17 1/4	1 15/16	1 5/16	1 5/16		2.7
	5 Channel End Caps (Male)	4 3/4	17 1/4	1 15/16	1 5/16	1 5/16		2.7
KH702	1 Channel Protector	36	11 1/2	1 5/8	1 1/4	-	11 700	13

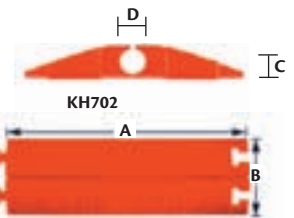

UTILITY CROSSOVER PADS

These lightweight and portable crossovers are manufactured from durable polyurethane and are ideal during maintenance operations or in emergency situations. Complete with carrying handle for easy positioning. Crossover pads are for rubber tired vehicles only and not equipment with metal tracks.



Model No.	Dimensions L" x W" x H"	Tunnel Dim."	Wt. lbs.
KH703	18 x 30 x 5	3	35
KH704	18 x 30 x 6	4 1/2	35



INDUSTRIAL RUBBER CORD COVERS

- Protect your cables from foot and vehicular traffic
- Constructed from non-conductive vulcanized rubber
- Suitable for indoor and outdoor use
- Stronger and longer lasting than PVC covers
- Excellent in temperatures from -40°C to 150°C
- Capacity: 5000 lbs. per axle

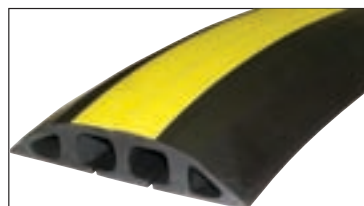

5' Length Model No.	10' Length Model No.	Description	Dimensions W" x H"	Channel W" x H"
KH907	KH908	1 channel	3 1/4 x 3/4	3/4 x 1/2
KH909	KH910	1 channel	3 x 1	1 x 3/4
KH911	KH912	2 channels	5 1/2 x 1 1/8	7/8 x 3/4
KH913	-	1 channel	6 x 1 7/8	1 1/2 x 1 1/2

DOCK EQUIPMENT

ALUMINUM DOCKBOARDS

- For truck or rail applications
- Curb design adds strength and prevents equipment run-off
- Skid resistant safety tread deck
- Bevelled edges for smooth access from either end
- Bend at upper end permits both ends of plate to lie flat
- Steel legs fit between dock and truck or railcar, prevent movement when in use
- High tensile aluminum alloy construction

Model No.	Cap. lbs.	Inside Curbs"	Overall Width"	Length"	Diff. Height"	Wt. lbs.
KH149	4000	51	54	60	9	164
KH150	4000	51	54	72	11	210
KH151	4000	57	60	60	9	177
KH152	4000	57	60	72	11	225
KH161	6000	51	54	48	7	143
KH162	6000	50	54	60	9	177
KH163	6000	50	54	72	11	225
KH164	6000	57	60	48	7	153
KH165	6000	56	60	72	11	240
KH166	6000	63	66	36	5	123
KH167	6000	63	66	48	7	163
KH168	6000	62	66	60	9	203
KH169	6000	69	72	48	7	174
KH177	8000	51	54	36	5	106
KH178	8000	50	54	48	7	149
KH179	8000	50	54	60	9	188
KH180	8000	50	54	72	11	236
KH181	8000	57	60	36	5	115
KH182	8000	56	60	48	7	160
KH183	8000	56	60	60	9	201
KH184	8000	56	60	72	11	251
KH185	8000	69	72	30	4	110
KH186	8000	68	72	48	7	181
KH187	8000	68	72	60	9	227
KH188	8000	68	72	72	11	282
KH189	8000	68	72	84	13	340
KH105	10000	51	54	36	5	127
KH106	10000	50	54	48	7	176
KH107	10000	50	54	60	9	222
KH108	10000	50	54	72	11	276
KH109	10000	56	60	60	9	239
KH110	10000	56	60	72	11	297
KH111	10000	63	66	36	5	148
KH112	10000	62	66	48	7	197
KH113	10000	62	66	60	9	256
KH115	10000	69	72	48	7	210
KH116	10000	68	72	60	9	273
KH117	10000	68	72	72	11	337
KH118	10000	68	72	84	13	403
KH119	12000	57	60	36	5	137
KH120	12000	56	60	48	7	190
KH121	12000	56	60	60	9	249
KH122	12000	69	72	36	5	158
KH123	12000	68	72	48	7	217
KH125	12000	68	72	84	13	192
KH126	14000	56	60	36	5	143
KH127	14000	56	60	48	7	190
KH128	14000	56	60	60	9	249
KH129	14000	56	60	72	11	313
KH130	14000	62	66	36	5	148
KH131	14000	62	66	48	7	204
KH132	14000	62	66	60	9	266
KH133	14000	62	66	72	11	333
KH134	14000	68	72	36	5	160
KH135	14000	68	72	48	7	220
KH136	14000	68	72	60	9	283
KH137	14000	68	72	72	11	353
KH138	14000	68	72	84	13	456
KH139	16000	68	72	60	9	330
KH140	16000	68	72	72	11	412
KH141	16000	68	72	84	13	540
KH142	18000	69	72	36	5	187
KH143	20000	68	72	36	5	187
KH144	20000	68	72	48	7	267
KH145	20000	68	72	60	9	344
KH146	20000	68	72	72	11	412
KH147	20000	67	72	84	13	564

FOB Weston, ON.

All dockboards are made to order (non-returnable)



Bevelled Edges

OPTIONS:

RAIL DOCKBOARDS

Fixed Spanlocks

- Provide quick and safe access between dock and railcar, or between railcars
- Sold in pairs

Model No. KH192

Adjustable Spanlocks

- Permit use of same board on truck or rail docks
- Easily adjusted for various spans
- Sold in pairs

Model No. KH190

FORKLIFT HANDLES

- Makes movement of heavy boards and plates easy and safe
- Recommended for boards and plates over 140 lbs.
- Sold in pairs
- Must be factory installed

Model No. KH191

HOW TO ORDER:

1. Determine required capacity:

90% of gross weight for forklift trucks;
67% of gross weight for powered pallet trucks

Example:

Wt. of Forklift + Wt. of Heaviest Load =
Gross Weight x .90 = Required Capacity
5500 lbs. + 10,000 lbs. = 15500 x .90 = 13500 lbs.

2. Select dockboard width: Add 12" to width of equipment to be used on dockboard.

3. Determine height differential: The vertical distance from dock floor to truck floor.

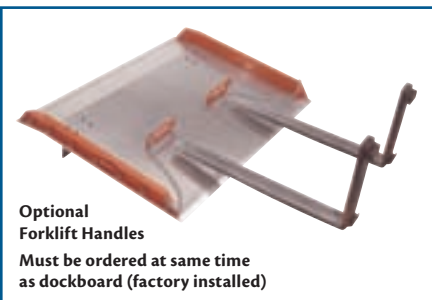

Optional Forklift Handles

Must be ordered at same time as dockboard (factory installed)

DOCKBOARD/RAMP COMBINATION

For a height differential exceeding 11", use a ramp in combination with dockboard. Each board can be converted to an equivalent-size ramp. Call us with your requirements.

ALUMINUM WHEEL RISERS

- Ideal for use when the loading dock is higher than the trailer bed
- Levels out trailer with dock
- Facilitates loading and unloading
- 24" wide
- 25 000 lbs. capacity per pair
- Sold in pairs



Model No.	Height"	Deck Length"	Approach Length"	Overall Length"	Wt. lbs. per pair
KH061	6	24	21	45	124
KH062	8	24	28	52	150
KH064	10	24	35	59	178
KH066	12	24	42	66	210
KH063	6	36	21	57	164
KH065	8	36	28	64	194
KH068	10	36	35	71	226
KH070	12	36	42	78	263
KH067	6	48	21	69	204
KH069	8	48	28	76	238
KH071	10	48	35	83	274
KH072	12	48	42	90	316

FOB Weston, ON.

All wheel risers are made to order (non-returnable)

ALUMINUM DOCKPLATES

Skid resistant safety tread deck. Bevelled edges allow smooth access from either end. Bend at upper end permits both ends of plate to lie flat. Steel legs fit between dock and truck; prevent movement when in use. High tensile aluminum alloy construction; no welds to break.

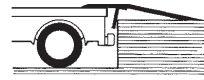
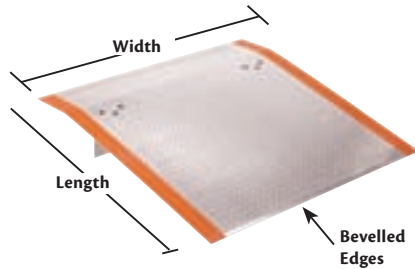

ABOVE DOCK LEVEL



Height Differential

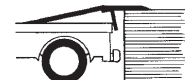

BELOW DOCK LEVEL

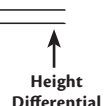

Height Differential

HOW TO ORDER:

- SELECT DOCKPLATE WIDTH:**
Add 12" to width of equipment to be used on dockplate.
- DETERMINE HEIGHT DIFFERENTIAL:**
The vertical distance from dock floor to truck floor. The height differential decides the necessary plate length.
- DETERMINE REQUIRED CAPACITY**

LIGHT-DUTY - 1/4" GA.

REGULAR-DUTY - 3/8" GA.

HEAVY-DUTY - 1/2" GA

EXTRA-HEAVY DUTY - 5/8" GA.

Model No.	Cap. lbs.	Wt. lbs.	Model No.	Cap. lbs.	Wt. lbs.	Model No.	Cap. lbs.	Wt. lbs.	Model No.	Cap. lbs.	Wt. lbs.	Dimensions W" x L"	Diff. Height"
KH206	700	53	KH148	1700	71	KH193	3000	97	-	-	-	36 x 48	7
KH207	800	60	KH153	2000	82	KH194	3500	110	-	-	-	42 x 48	7
KH208	1800	36	KH154	4500	48	-	-	-	-	-	-	48 x 24	3
KH209	1450	44	KH155	3600	60	-	-	-	-	-	-	48 x 30	4
KH210	1250	52	KH156	3000	70	KH195	5400	94	-	-	-	48 x 36	5
KH211	1050	60	KH157	2600	82	KH196	4600	110	-	-	-	48 x 42	6
KH212	900	67	KH158	2200	92	KH197	4000	124	-	-	-	48 x 48	7
KH213	760	76	-	-	-	-	-	-	-	-	-	48 x 54	8
KH214	600	83	KH159	1500	114	KH198	2700	155	-	-	-	48 x 60	9
KH215	400	100	KH160	1100	136	KH199	2000	184	-	-	-	48 x 72	11
KH216	2200	43	KH170	5600	59	KH200	10000	79	KH328	15600	98	60 x 24	3
KH217	1800	54	-	-	-	-	-	-	-	-	-	60 x 30	4
KH218	1500	63	KH171	3700	86	KH201	6700	114	KH329	10500	141	60 x 36	5
KH219	1300	73	-	-	-	-	-	-	-	-	-	60 x 42	6
KH220	1100	83	KH172	2800	113	KH202	5000	151	KH330	7800	186	60 x 48	7
KH221	880	102	KH173	2200	140	-	-	-	-	-	-	60 x 60	9
KH222	2600	51	KH174	6700	76	KH203	12000	94	KH331	18700	115	72 x 24	3
KH223	1950	63	-	-	-	-	-	-	-	-	-	72 x 30	4
KH224	1650	74	KH175	4500	105	KH204	8000	135	KH332	12600	166	72 x 36	5
KH225	1300	97	KH176	3300	135	KH205	6000	178	KH333	9400	220	72 x 48	7
KH226	900	121	-	-	-	-	-	-	-	-	-	72 x 60	9

FOB Weston, ON.

All dockplates are made to order (non-returnable)

RAIL CHOCKS

- Provides effective means of blocking railcars for safe loading and unloading
- Steel points on chock heads bite into rail to prevent sliding
- Integral 7 1/2" x 9 1/2" sign
- Single rail chock for stoppage in one direction; double rail chock for stoppage in both directions
- Choice of exposed (above ground) or flush (level with ground) chocks
- Standard finish in yellow

Model No.	Description	Wt. lbs.
FOR EXPOSED RAIL		
KH016	Single Chock	12
KH021	Double Chock	16
FOR FLUSH RAIL		
KH015	Single Chock	12
KH020	Double Chock	16

KH016



KH021

POLYETHYLENE BOLLARD COVERS

- Enhance and protect the appearance of your steel bollards
- Reduce maintenance; avoid scraping and painting each spring
- Constructed of 1/8" UV stable polyethylene for durability
- Easy installation with patented *GripperTabs™* included
- Safety yellow with reflective red tape or high visibility red with white reflective tape, for great visibility day or night
- 5-year warranty against fading and cracking

Yellow Model No.	Red Model No.	Fits Bollard Diameter"	Fits Bollard Length"	Wt. lbs.
KH806	KH836	4	52	7
KH808	KH838	4	64	9
KH809	KH839	6	52	8
KH810	KH840	6	60	9
KH811	KH841	6	72	10



Before



After

DOCK EQUIPMENT

TRAILER STABILIZING JACKS

- Keeps tractorless trailers leveled while being loaded or unloaded
- Prevents accidents if wheel support collapses
- Stabilizes vehicle against load shifts
- Lowered height: 39 1/2"
- Raised height: 51"
- Removeable 37 1/2" positioning and ratcheting handle
- 8" diameter support pad
- 8" wheels
- 100 000-lb. supporting capacity each and 40 000-lb. lifting capacity
- Recommended use in pairs**
- 1-year warranty**

Model No. KH777



AUTO STAND TRAILER STABILIZING JACKS

- Heavy gauge steel construction
- Large base pad (17" x 18 1/2")
- Gas activated, self levelling system
- 10" diameter semi-pneumatic rubber tires for easy handling
- 41"- 50 1/2" height range
- Large trailer contact pad
- Capacity: 100 000 lbs.
- Only one required per trailer
- 1-year warranty**

Model No. KH791



MOLDED DOCK BUMPERS

- Protects building and dock areas
- Shockproof, tear and freeze resistant



KH005

Model No.	Type	Face Dim. W" x H"	Overall Projection"	Wt. lbs.
KH005	Rectangular	13 x 10	4	16
KH009	Rectangular	18 x 10	4	32

EXTRUDED RUBBER DOCK FENDERS

D-4 DOCK FENDERS

- Guard against damaging impact
- Made of age, weather and abrasion-resistant synthetic rubber
- Easy to install and the trim appearance makes them well suited for use on trucks and truck docks
- Half oval shape allows radius to widen upon impact creating better deflection
- Easily installed manually or by power tools
- Hardware is concealed when installation is complete

Note: All given dimensions are nominal and may vary an average of 5% in manufacturing process.

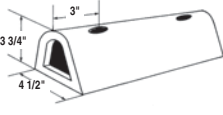
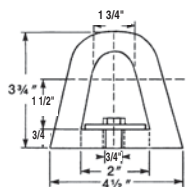

PALLET PULLERS

- Efficient way to unload pallets from trucks
- Hardened teeth give positive grip in any pallet
- One-person operation
- Pulls pallets straight or sideways to get out of tight spots
- Capacity: 5000 lbs.



KH863

Optional 20' hook and chain



ML319

Model No.	Description	Wt. lbs.
KH863	Pallet Puller	16
ML319	20' Hook and Chain	5

AUTO STAND PLUS

- Heavy gauge steel construction
- Gas activated, self-levelling system
- Ergonomic lever action to safely pin, removing the need to bend over
- 16" diameter semi-pneumatic wheels allow for easy outdoor manoeuvring
- Large base pad: 17" x 18 1/2"
- Large trailer contact pad
- Capacity: 100 000 lbs.
- Only one required per trailer

Model No. ML786



CARGO BARS & HOOPS

- Prevent cargo from shifting and damage
- No permanent installation or adaptation required
- Quick installation and removal
- One-piece cargo bar aluminum 1 1/2" square 14-gauge tubing
- Mechanical ratchet will not slip or vibrate loose
- 4" square rubber protected end pads
- Adjusts from 89" to 105"
- Galvanized steel cargo hoops measure 29" L x 24" W
- Expands the retention area to secure a large area of smaller boxes or cartons
- Hardware included

One piece cargo bar adjusts from 89" to 105" long



Hoops come complete with installation hardware



Model No.	Description	Wt. lbs.
KH574	Aluminum Bar	17
KH575	Hoops (pair)	15

MOUNTING D-4 DOCK FENDERS

- On Wood:** Use 1/2" lag screws
- On Concrete:** Use 1/2" self-drilling fasteners
- On Steel:** Weld 1/2" studs on centers as required



Mounting Bar

In all cases, a drilled metal bar 3/16" x 1 1/2" should be inserted in the bore of the fender to act as a continuous washer.



Diagonal



Horizontal



Vertical

Fender Drilled Model No.	Mounting Drilled Model No.	Dimensions L" x W" x H"	Anchor Holes	Approx. Wt. lbs.
KH658	KH662	12 x 4 1/2 x 3 3/4	2 req., 6" *	4
KH659	KH663	18 x 4 1/2 x 3 3/4	2 req., 12" *	6
KH660	KH664	24 x 4 1/2 x 3 3/4	2 req., 18" *	9
KH661	KH665	36 x 4 1/2 x 3 3/4	3 req., 15" *	11

* Between holes

WHEEL CHOCKS

RUBBER WHEEL CHOCKS

- Highly resistant to abrasion, impacts, corrosion, sun, salt, ozone and oil
- Steel ring on back
- 9 1/2" L x 6 1/2" W x 8 1/2" H
- Weight: 11 lbs.

Model No. KH032



LAMINATED RUBBER CHOCKS

- Designed to fit curvature of tire for a strong grip
- Extra heavy-duty laminated rubber and steel construction for use with heavy utility trucks and equipment
- Load capacity: Up to 40000 lbs.

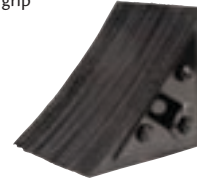

Model No.	Approximate Dimensions					Wt. lbs.
	L"	x	W"	x	H"	
KH603	8	x	8	x	8	14

IRON WHEEL CHOCKS

- Suited for your toughest jobs



KH799



KH951

Model No.	Chock Material	Dimensions					Colour	Wt. lbs.
		L"	x	W"	x	H"		
KH799	Ductile Iron	12	x	8	x	9	Blue	19
KH951	Ductile Iron	7 1/4	x	8 1/2	x	8 1/2	Safety Yellow	14

RUBBER CHOCKS

Fabricated of a tough rubber compound, reinforced for maximum wearability and strength.

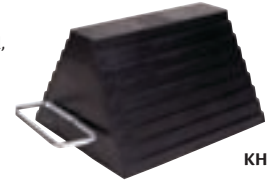

KH600

Model No.	Type	Approximate Dimensions					Wt. lbs.
		L"	x	W"	x	H"	
KH600	Handle	9	x	8	x	6	10
KH601	Eyebolt	9	x	8	x	6	10

ALUMINUM WHEEL CHOCKS

- High in strength but lightweight
- Resists the effects of oil, salt, corrosion and weather
- Non-sparking

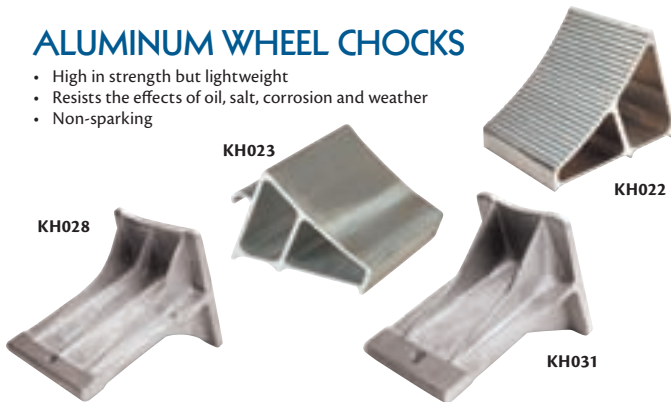

Model No.	Dimensions					Wt. lbs.
	L"	x	W"	x	H"	
KH023	6	x	7	x	6	4
KH022	7	x	10 3/4	x	8	7
KH031	6	x	9	x	7	4
KH028	8	x	11 1/2	x	9	9

ICE CHOCKS

- Formed steel
- "Tooth" like bottom assures reliable grip
- Lightweight and dependable
- Maximum holding power for snow and ice
- Overall dimensions: 10 1/2" L x 8" W x 9 1/4" H
- Powder-coated safety yellow finish for high visibility

Model No. KH964

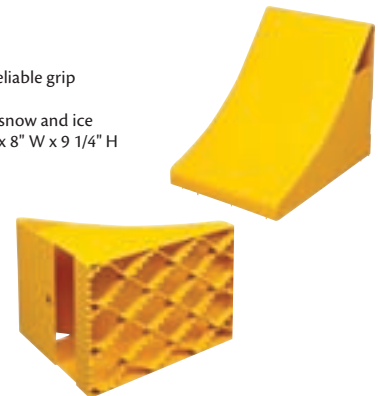

WHEEL CHOCK ACCESSORIES

SECURITY CHAINS

- 18' steel chain attaches chock to dock
- Prevents misplacement, theft
- Zinc plated for corrosion resistance
- Diameter: 0.14 (3 mm)
- Working load limit: 255 lbs. (116 kg)
- Comes with hook
- Weight: 4 lbs.

Model No. KH027

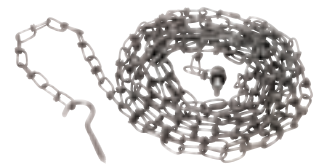

CAUTION SIGNS

- 10" x 14"
- Black letters on yellow field
- Weight: 6 oz.

Model No. SAT137 English

Model No. SEE554 French



URETHANE WHEEL CHOCKS

- Safety orange for greater visibility
- Molded-in hole through width of chock for attaching chain (sold separately)
- For use with off road vehicles
- 17" L x 14" W x 14" H
- Weight: 25 lbs.

Model No. KH025



URETHANE WHEEL CHOCKS

- Safety orange for greater visibility
- Molded-in hole through width of chock for attaching security chain (chain sold separately)
- Overall dimensions: 11" L x 8" W x 8" H

Model No. KH897

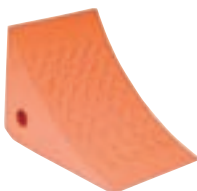

WHEEL CHOCK WALL BRACKETS

- Sturdy yellow metal construction
- Fits chocks up to 10" wide
- Prevents loss of chock

Model No. KH963



DOCK LIGHTS

DOCK LIGHTS

- The adjustable models allow flexible horizontal and vertical positioning
- 1 1/2" 14-gauge square steel tubing
- Two-piece wall bracket assures secure mounting
- Available with either metal or polycarbonate head will not dent, bend or break, and stays cool to the touch
- Comes with wire lamp guard
- PAR-38 lamp not included
- Certified for sale in Canada by an accredited certification body

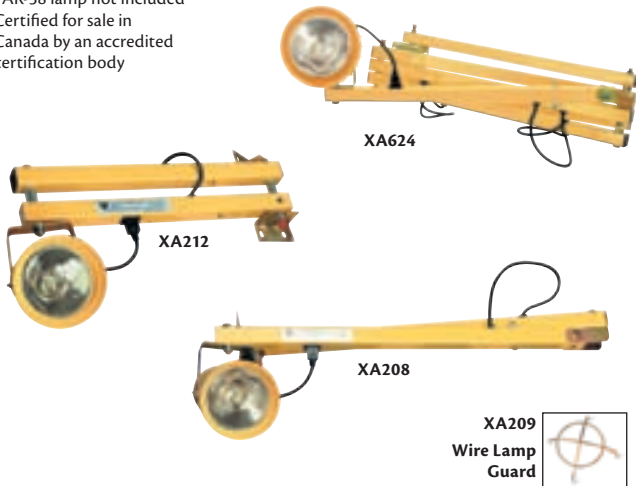

LED DOCK LIGHTS

- Designed to light up the longest of trailers with no wasted light
- LEDs last over 50,000 hours with low heat emission
- Flexible arm allows for unlimited positioning
- Housing is made from durable polycarbonate polymer resistant to cold temperatures
- Low energy usage of 16 W
- Light output equivalent to a 150 W PAR28 bulb
- 42 1/2" L x 6" H
- Weight: 12 lbs.
- Certified for sale in Canada by an accredited certification body

Model No. XC756



HALOGEN DOCK LIGHTS

- 40" full extension
- Tempered glass lens with protective wire guard
- Light fixture can pivot up and down
- Arm has spare bulb holder built in
- Suitable for wet areas
- On/Off toggle switch
- 6' cord with ground
- Includes two 500 W quartz halogen bulbs
- Certified for sale in Canada by an accredited certification body



Model No.	Description	Wt. lbs.
XA673	Dock Light	15
XC464	Replacement Bulb	-

Model No.	Arm Length"	Head Type	Wt. lbs.
ADJUSTABLE SINGLE STRUT			
XA213	40	Metal	13
XA208	60	Metal	16
XC446	40	Polycarbonate	12
XC447	60	Polycarbonate	15
DOUBLE STRUT - HORIZONTAL POSITIONING ONLY			
XA212	24	Metal	13
XA211	40	Metal	16
XA214	60	Metal	20
XA349	90	Metal	29
XC448	24	Polycarbonate	12
XC449	40	Polycarbonate	15
XC450	60	Polycarbonate	19
XC451	90	Polycarbonate	28
ADJUSTABLE DOUBLE STRUT			
XA619	40	Metal	18
XA620	60	Metal	21
XA621	90	Metal	31
XA623	40	Polycarbonate	17
XA624	60	Polycarbonate	20
XA625	90	Polycarbonate	30

ACCESSORIES

Model No.	Description
XA209	Replacement Wire Guard for Metal Head
XC731	Replacement Wire Guard for Polycarbonate Head
XB235	Replacement PAR-38 Lamp
XC224	Replacement Metal Head
XC445	Replacement Polycarbonate Head

LED STOP & GO LIGHTS

Loading dock Stop & Go light is a safety signaling device that alerts truck drivers and loading dock personnel to the safety status of docked or docking trucks.

- Simple, reliable and cost-effective warning system that reduces the risk of accidents
- Establishes a clear line of communication between drivers and dock personnel
- Safety yellow polypropylene housing will not rust, pit, dent or corrode
- Shallow depth of unit (less than most dock bumpers) prevents damage to the Stop & Go light
- Integral eyebrow-type sun visors create extended visibility
- Mounting holes conform to standard building specifications
- Units can be used indoors or outdoors
- 6 3/8" W x 3 3/4" D x 11 3/8" H
- Lens diameter: 4 1/4"
- Certified for sale in Canada by an accredited certification body



12 VDC	Model No.			Description	Wt. lbs.
	24 VDC	115 VAC			
XC100	XC101	XC102		Without Flasher or Switch	2
XC103	XC104	XC105		With Flasher and Switch	2
XC106	XC107	XC108		Set, Including One of Each of the Above	4

SEE PAGE B194 FOR OUR SELECTION OF LIND EQUIPMENT WORK REELS



STEEL DRUMS

- Open head 55 U.S. gallon design complies with stringent UN regulations for packing non-dangerous and dangerous goods in packing groups II and III; salvage drum is good for packing groups I, II and III in solids only
- Closed head 55 U.S. gallon design meets UN regulations for packing of dangerous and non-dangerous goods in the packaging groups II and III and also complies with ISO 15750 standard and other major international standards for steel drums (ANSI, EN)
- Drums feature 2" x 3/4" *Tri-Sure*® fittings and are available in lined or unlined, except 85 U.S. gallon salvage drums which have a plain cover and no lining
- Colours: 55 U.S. gallon open and closed head drums are standard black; 85 U.S. gallon salvage drum is yellow with "Salvage Drum" printed in black

UN Regulations:

- A) UN1A1Y1.4140
- B) UN1A1Y2755
- C) UN1A1X1.8300



Unlined Model No.	UN Compliance	Lined Model No.	UN Compliance	Head Type	Capacity U.S. Gallons	Wt lbs.
DC145	A	DC146	B	Open	55	37
DC147	C	DC461*	C	Closed	55	35
SALVAGE DRUM						
DC130	C	-	-	Open	85	77

* Unit is painted white

ACCESSORIES

Model No.	Description
DC450	2" Steel Plug with Buna Gasket
DC460	Lid for Open Head Steel Drum, No Fittings
DC455	Bolt Ring for Open Head Steel Drum

LOK-RIM® FIBRE DRUMS

- Provides thermal insulation and protects sensitive products
- Full-open top assures quick filling and dispensing, while the fibre covers and steel chimes reinforce top and bottom
- Unique *Lok-Rim*® closure allows easy opening and closing and has a tamper evident sealing feature
- Will not corrode and contaminate product
- Compatible with a variety of non hazardous dry and solid products*
- Economical and stackable
- Made of FDA compliant materials



Model No.	Capacity Gal.	Capacity lbs.	Wt. lbs.
DC427	30	225	9.4
DC425	55	300	17
DC426	55	550	19

* Compatible with semi-liquids when a polyethylene liner/bag is applied

POLYETHYLENE DRUMS

UN-approved plastic drums are manufactured using state-of-the-art technologies to meet the stringent demands of chemical compatibility with hazardous and non-hazardous products as well as reliability and safety requirements. Drums are made from a high molecular weight, high-density polyethylene resin which makes them extremely strong and rigid, allowing for easy handling and low shipping cost. Plastic drums save warehouse space because they are stackable and can be stored outside without rusting. In addition, total packaging costs are decreased when they are reused.



Drums are manufactured in accordance with one of the following UN regulations:

- A) 1H1/Y1.9/150
- B) 1H2/Y250/S

Blue Model No.	Black Model No.	Natural Model No.	Head Type	Cap U.S. Gallons	Fittings	UN Regulation	Wt lbs.
DC139	DC140	DC141	Closed	30	2" BTR & 2" NPS	A	14
DC142	DC143	DC144	Closed	55	2" BTR & 2" NPS	A	21
DC137*	DC138*	-	Open Straight	55	-	B	22

ACCESSORIES

Model No.	Description
DC149	2" Buttress Coarse Thread
DC150	2" NPS Fine Thread

* Comes standard with cover and steel lever-locking ring

LIQUIPAK® FIBRE DRUMS

- Interior is lined with heavy duty polyethylene, making it the perfect solution for non-hazardous liquids
- Full-open top assures quick filling and dispensing, while the plastic covers and steel chimes reinforce top and bottom
- Will not corrode and contaminate product
- Economical and stackable
- Complete with bung and vent poly cover fully assembled with locking ring
- Made of FDA compliant materials



Model No.	Capacity Gal.	Capacity lbs.	Wt. lbs.
DC428	30	400	12
DC429	55	600	17.5
DC430	55	600	17.5

RECTANGULAR POLY TIGHT HEAD CONTAINERS

- Suitable for storing and shipping liquid, granular and semi-solid chemicals, detergents, petroleum products, food products, pharmaceuticals and acids
- Recessed handle and anchoring system ensure safe multiple stacking
- Protruding stabilisers prevent tipping
- Vents are included but leakproof screw caps are extra
- Container capacity of 20 litres
- 11 1/2" L x 9 1/2" D x 9 3/4" H



Model No.	Mfg. No.	Description	Opening mm
DC163*	158	Yellow Container Only	63
DA684*	240	Natural Container Only	60
DA685	284	Security Cap	60

* Regular cap not included

DRUM LINERS

ACCORDION LINERS FOR 55-GALLON DRUMS

- Seamless insert made of FDA-compliant materials
- Accordion pleat design adjusts to varying heights of reconditioned drums
- Formed lip grips chime of drum and stays in place during follower plate pumping

Model No.	Wall Thickness	Qty /Case
DC338	15 mils	20
DC340	18 mils	15
DC339*	15 mils	20

* Anti-static



STRAIGHT-SIDED LINERS FOR 16, 30 & 55-GALLON OPEN HEAD STEEL DRUMS

- Made of FDA-compliant materials
- Smooth wall inserts withstand mixing and pumping applications
- Available in anti-static
- Available in polypropylene for hot-fill applications to 440°F
- DC344 used for hot-fill applications

Model No.	Wall Thickness	Drum Gallons	Qty /Case
DC352	15 mils	16	15
DC336	15 mils	30	25
DC337	15 mils	55	20
DC342*	18 mils	55	15
DC343	24 mils	55	15
DC344	15 mils	55	10

* Anti-static



LINERS FOR 5-GALLON STEEL PAILS

- Made of FDA-compliant materials
- Straight-sided inserts for steel pails are ideal for small batch mixing
- Choose from pliable LDPE or solvent-resistant HDPE
- Available in anti-static
- Available in polypropylene for hot-fill applications to 300°F
- DC349 used for hot-fill applications

Model No.	Wall Thickness	Material	Qty /Case
DC347	15 mils	LDPE	100
DC348	15 mils	HDPE	100
DC349	15 mils	Polypropylene	100



PLASTIC PAIL LINERS

- Seamless 14" tall tapered insert provides custom fit for plastic pail
- Average 15-mil thick
- FDA-compliant materials

Model No.	Material	Gallons	Qty/Case
DC350	HDPE	5	100
DC351	LDPE	5	100



ULTRALINER DRUM LINERS FOR 55-GALLON STEEL & FIBRE DRUMS

- Heavy-duty 18-mil insert with ultra thin lip for easy lid closure

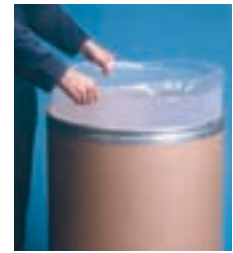

Model No.	Dia"	Wall Thickness	Drum Type	Qty /Case
DC345	21 1/2	18-mil LDPE	Fibre	32
DC346	22 1/2	18-mil LDPE	Steel	15

FORMFIT LINERS FOR 55-GALLON DRUMS

- Cylindrical film liners are heat-sealed and made of FDA-compliant materials
- Available in 40" height to fold over drum or 53" height to tie off
- Available in mil thickness of 4, 8 or 10
- Available in anti-static for solvent-based applications



Model No.	Height"	Wall Thickness	Qty /Case
DC353	40	4 mils	100
DC354	40	8 mils	50
DC355	40	10 mils	50
DC356	53	4 mils	100
DC357	53	8 mils	50
DC358	53	10 mils	50
DC359*	53	8 mils	50

* Anti-static

ELASTICIZED DUST CAPS FOR 5, 30 & 55-GALLON CONTAINERS

- Clear 4-mil LDPE caps with elasticized band for easy installation
- Available in anti-static

Model No.	Drum Gallons
DC371	5
DC375*	5
DC372	30
DC376*	30
DC373	45
DC377*	45

* Anti-static



FUSIBLE LINK SELF-CLOSING DRUM COVERS

Convert open top 45-gallon steel drums into fire-safe receptacles for combustible trash. A replaceable fusible link assembly inside the cover melts at 160°F, automatically slamming the cover shut if a fire occurs in the drum. Steel construction; solvent resistant, red baked-on-enamel finish. Fits drums from 22 1/2" to 22 3/4" in diameter. FM approved. Wt. 16 lbs.

Model No. DA097 Mfg. No 26750



DRUM WRENCHES & ACCESSORIES

BUNG NUT WRENCHES

- Fits almost any metal or plastic, male or female bung nuts or plugs
- 13" overall length
- Offset handle
- Weight: 4 lbs.

Model No. DA637

Annealed ductile iron

Model No. DA638

Non-sparking, manganese bronze alloy

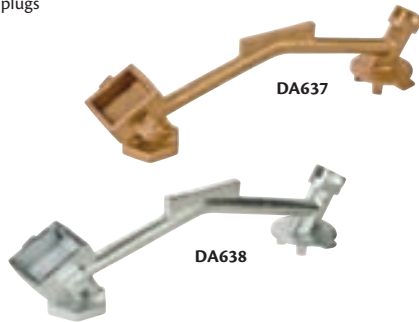

KLETON

DELUXE PLUG WRENCHES

- Non-sparking bronze alloy wrench fits virtually all industrial drums including those with square or hex plugs, male or female bung nuts or plugs and fittings with lugs and crossbars
- Built-in 1 1/4" wrench for tightening faucets into drums; eliminates the need for extra tools
- Weight: 2 lbs.

Model No. PE359



KLETON

UNIVERSAL PLUG WRENCHES

- Fits virtually all steel, plastic and fibre drum plugs
- 15 1/2" long for extra leverage and hand clearance
- Weight: 4 lbs.

Model No. DA635

Solid ductile iron

Model No. DA636

Non-sparking, zinc aluminum alloy



MORSE

DRUM WRENCHES

- Socket head which fits over 3/4" and 2" steel and plastic hex-head plugs
- Also fits other types of closures

Model No. DA647 Non sparking - 2.5 lbs.

Model No. DA643 Socket head - 2.0 lbs.



DRUM DEHEADERS

- Opens any standard size and gauge drum in minutes
- Contoured to drum radius; fast, one-hand operation
- Leaves edge smooth
- Constructed of fine forged steel with a precision quality steel blade
- Weight: 6 lbs.

Model No. DA312

Drum deheader

Model No. DA299

Replacement blade



DRUM UPENDERS

- 40" long upender provides the necessary leverage for moving horizontal drums to a standing position
- 2 1/2" wide toe plate prevents denting of drum
- 1 1/2" hook fits over most drum heads
- Weight: 12 lbs.

Model No. DA653



MORSE

CAN TIPPERS

- Handles 5-gallon round cans
- Safety lock holds drums securely
- Dispensing height of 10"
- Folds for easy storage
- Capacity: 75 lbs.
- Weight: 9 lbs.

Model No. DA651



MORSE

PLASTIC PAIL OPENERS

- Ideal for opening plastic buckets and pails
- Unique leverage point ends cover distortion and cutting
- Holds pail down while it lifts lid evenly; lid lifts off in seconds
- Aluminum construction
- 16" long
- Weight: 0.5 lbs.

Model No. DA639



PAIL PALS

- Designed to open and close virtually any type of steel or plastic pail
- Cast steel construction for durability
- Yellow zinc-plated finish with molded blue plastic hand grip
- Includes a special cutting tool to open sealed lids on plastic pails

Model No. DC041



DRUM ACCESSORIES

POLY-DRUM TOPPER™

Snaps directly onto any 45-gallon open or closed-head drum to keep out debris and protect drum tops.

Exterior dimensions:
25 1/2" dia. x 3 3/4" H



Model No.	Mfg. No.	Description	Wt. lbs.
SAQ193	3065-BK	Poly-Drum Topper™	1.5

DRUMS-UP™ TRAYS

THE INCIDENTAL SPILL SOLUTION!

- Catch liquid before it reaches the floor, reducing the risk of slip and fall injuries
- Ideal for use as a drum pumping station
- Secondary containment unit features a unique geometric design covering more floor area
- Drain hole makes emptying easy

DRUMS-UP™

- Contains drips for containers up to 55 US gallons
- Control nuisance spills from drums with a 20 US gallon capacity

DRUMS-UP JR™

- Containment for 16 to 30 US gallon drums and 5-gallon pails
- 7 1/2 US gallon capacity



DA104

Drum or pail not included



SD361



Model No.	Mfg. No.	Description	Dimensions			Wt. lbs.
			Dia."	x	H"	
DA104	8091-YE	Drums-Up™	34	x	7 1/4	12
SD361	8200-YE	Drums-Up Jr™	21 1/2	x	7 1/2	4

SAFETY DRUM FUNNELS

- Suitable for handling flammables, minimise potentially dangerous spills
- Large 10 3/4" mouth provides quick dumping
- Steel construction with 6" flame arrestor for the DA102 and 32" flame arrestor for the DA101
- Hinged cover with fusible link reduces spread of vapours
- 2" NPS
- FM approved



Model No.	Mfg. No.	Flame Arrestor"	Wt. lbs.
DA102	8207	6	12
DA101	8205	32	12

UNIVERSAL POLY-DRUM FUNNEL™

- Patented scalloped design, high sidewall and bung fitting holders
- For use with 30 and 55 US gallon drums
- Funnel's nest for compact shipment
- Safety funnel includes a non-sparking safety bung closure with flame arrestor for use with flammable liquids
- Optional cover keeps the weather out
- Dimensions: **Exterior** - 26" dia. x 5 1/2" H; **Interior** - 22" dia. x 4" H

SAH566



SAH567/SAH565

Model No.	Mfg. No.	Description	Wt. lbs.
SAH565	3004-4E	Funnel	3
SAH566	3004-YE-SF	Safety Funnel	5
SAH567	3040-YE	Funnel Cover	3



POLY-PAIL FUNNELS™

Mounts to 3 1/2, 5 and 6-gallon tight-head pails. Also fits open top pails with 12" diameter. Optional Poly-Pail Funnel™ cover available.

POLY-PAIL FUNNEL™

- **Exterior Dimensions:** 9 1/4" top dia. x 11" bottom dia. x 2 3/4" H
- **Interior Dimensions:** 8 1/2" x 2 3/8" side wall height

POLY-PAIL FUNNEL™ COVER

- **Exterior Dimensions:** 9 1/4" dia. x 2 3/8" H



Model No.	Mfg. No.	Description	Wt. lbs.
DA098	3005-YE	Poly-Pail Funnel™	2
SG291	3051-YE	Poly-Pail Funnel™ Cover	3

SAFETY FUNNELS WITH VENT

- Provides safe waste solvent disposal due to automatic pressure and vacuum relief
- 9" diameter polyethylene funnel comes with brass safety vent and 6" flame arrestor
- Cap comes with safety chain to prevent loss
- 2" NPS
- FM approved
- Wt.: 4 lbs.

Model No. DA103 Mfg. No. 8211



MANUAL-CLOSING MOLASSES GATE VALVES

- Excellent for dispensing heavy oils, light grease, varnish, molasses, honey, cream and other non-flammable heavy viscous fluids from drums and containers
- All gates have 45-60° discharge for optimum flow control
- Durable cast iron body, painted black enamel finish
- Machined and lapped brass faceplate for smooth operation and perfect seal
- Can be padlocked in sizes up to and including 2"

Model No.	NPT Inlet Size"	Wt. lbs.
STANDARD GATE WITH 2" HANDLE		
DA059	3/4	1.5
DA060	1	2.0
DA061	1 1/4	2.4
DA062	1 1/2	2.9
DA063	2	3.2
DA057	3	6.8
DA058	4	15.5

Model No.	NPT Inlet Size"	Wt. lbs.
STANDARD GATE WITH 4" HANDLE		
DA055	1 1/2	4.3
DA056	2	4.6
DA054	3	7.7
GATE VALVE WITH LOCK NUT, 2" HANDLE		
DA051	3/4	1.6
DA052	1 1/2	3.2
DA053	2	3.6

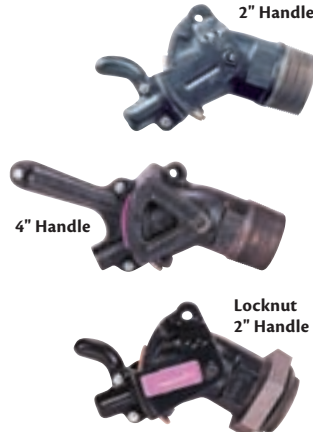

Note: These faucets are intended for use with non-flammable viscous liquids stored in or dispensed from non-pressurized containers at ambient room temperature.

SELF-CLOSING FAUCETS

- For non-flammable liquids only
- No flame arrestor
- 3/4" pipe thread
- Can be padlocked closed
- Natural zinc die cast finish

Model No. PE365



SELF-CLOSING FAUCETS W/SCREEN

- For use with flammable and non-flammable liquids
- Flame arrestor safety faucet
- Standard 3/4" tapered pipe thread
- Can be padlocked closed
- Natural zinc die cast finish

Model No. PE364



MANUAL-CLOSING POLY FAUCETS

- Ideal for use with non-flammable, often corrosive liquids
- Half turn on/off; stays open until shut-off
- Use 2" size for thick, viscous liquids or larger volume flow of thin liquid



Model No.	Bung"	Wt. lbs.
DA048	2	0.50
DA049	3/4	0.08

FAUCETS

- Approved for use with oils and non-flammables compatible with stainless steel
- Internal flame arrestor
- Teflon[®] gasket, 3/4" NPT connection
- FM approved

Model No.	Description	Wt. lbs.
DC404	Natural Die Cast	0.5
DA043	Stainless Steel	2.00



HORIZONTAL BRASS VENTS

- Horizontal vents are for use with drums in the horizontal pouring position
- Automatically relieves pressure at 5 PSI
- Flame arrestor prevents sparks and flame from igniting contents
- Manual vacuum relief by lifting and rotating the valve stem
- Maximum flow of 220 CFM at 20 PSI
- Fits 2" NPS bung in steel or plastic drums

Model No. PE362



SELF CLOSING GATE VALVES

- For use with viscous non-corrosive fluids heavier than SAE30 motor oil
- Heavy-duty brass construction
- Self-closing Teflon[®] blade has fast, positive shut off when handle is released
- 4 1/2" wide handle
- Wide opening permits maximum flow
- Fits 2" bung in steel or plastic drums
- Weight: 7 lbs.

Model No. PE363



UNIVERSAL DRIP PANS

- Absorbs problem leaks and helps keep floors clean and safe
- Holds up to one gallon of liquid
- Pan is filled with polypropylene sorbent for oils, water-based and other non-aggressive liquids
- Rigid, sturdy construction helps prevent spillage during handling
- Dimensions: 10 1/2" square x 3" D
- Weight: 0.08 lbs.

Model No. DA105



GRADUATED DRUM GAUGES VERTICAL DRUM GAUGES

- Constructed of heavy gauge glass in plated steel body with Buna-N seals
- Excellent for most oils, solvents and chemicals
- Combination gauge and faucet permits uninterrupted draining of drum contents with gauge in place
- Mounts through 3/4" bung hole
- Weight: 3 lbs.



- Graduated in gallons, litres and percentage remaining in drum
- Heavy steel and plastic construction with leak proof neoprene gaskets
- Resistant to oil and many chemicals
- Available for 3/4" or 2" NPT bung opening
- Weight: 1 lbs.



DRUM FILL GAUGES

- When drum is almost full, indicator "pops up" to warn you
- Fits in standard 3/4" bung opening
- Length: 5"
- Bright red and yellow molded polyethylene
- Weight: 0.2 oz.
- FM approved

Model No. DA066

Mfg. No. 8530



WESCO[®]

Model No.	Description
DA064	Gauge Only
DA065*	Gauge with Faucet

* Zinc die cast faucet FM approved for viscous liquids only; no flame arrestor.

Model No.	Bung"
DA069	3/4
DA068	2

JUSTRITE[®]

DRUM HEATERS

NEMA CONFIGURATION



NOTE: DO NOT USE THESE HEATERS IN HAZARDOUS AREAS OR TO HEAT FLAMMABLE MATERIALS. FOR INDOOR USE ONLY.

FLEXIBLE DRUM & PAIL HEATERS

APPLICATIONS

- Preheating • Viscosity control
- Mixing, dipping or pouring
- Temperature control • Freeze protection

FEATURES

- Durable and tough reinforced fiberglass silicone rubber
- Resists moisture, mildew and most chemicals
- Easy to clean and store
- Heavy-duty spring latch assembly, installs or removes in seconds
- 6' power cable w/ NEMA 5-15P plug for the 120 V models
- 6' bare end power cable for the 220 V models



Description	Drum Material	Thermostat range					
		70°-160°F		75°-205°F		75°-425°F	
		120 V	220 V	120 V	220 V	120 V	220 V
5 US GALLONS							
6" wide 300 W	Polyethylene	DC295	DC296	*	*	*	*
3" wide 300 W	Metal	DC297	DC298	DC299	DC300	DC301	DC302
15 US GALLONS							
6" wide 375 W	Polyethylene	DC303	DC304	*	*	*	*
3" wide 500 W	Metal	DC305	DC306	DC307	DC308	DC309	DC310
30 US GALLONS							
6" wide 500 W	Polyethylene	DC311	DC312	*	*	*	*
3" wide 750 W	Metal	DC313	DC314	DC315	DC316	DC317	DC318
55 US GALLONS							
6" wide 750 W	Polyethylene	DC319	DC320	*	*	*	*
3.25" wide 1000 W	Metal	DC321	DC322	DC323	DC324	DC325	DC326
4.75" wide 1500 W	Metal	DC327	DC328	DC329	DC330	DC331	DC332

* Polyethylene pails should not be heated beyond 160°F

THERMOSTAT CONTROL HEATERS

- Heats materials with good heat receptivity
- Made of aluminised steel; conjunction box made of galvanised steel
- Increases flow rate of viscous material
- Reaches and maintains a given temperature
- Thermostat bulb senses temperature and controls pre-set heat
- Three-heat switch allows three wattage ratings per thermostat setting
- HIGH setting uses Max. Watts; MEDIUM, 1/2 Max. Watts; LOW, 1/4 Max. Watts
- Neon pilot light
- 6' power cord



Model No.	Drum Cap. Gal.	Drum Dia. "	Temp Range	Plug Type NEMA no.	Volts	Watts	Wt. lbs.
DA072	55	22 1/2	60-250°F	5-15	120	1750	15
DA073	55	22 1/2	200-400°F	5-15	120	1750	15
DA092	55	22 1/2	60-250°F	5-20	120	1920	15
DA093	55	22 1/2	200-400°F	5-20	120	1920	15
DA094	55	22 1/2	60-250°F	6-15	240	3000	15
DA095	55	22 1/2	200-400°F	6-15	240	3000	15
DA090	5	11 1/4	60-250°F	5-15	120	1500	5
DA091	5	11 1/4	200-400°F	5-15	120	1500	5
DA087	16	14 1/2	60-250°F	5-15	120	1500	8
DA088	16	14 1/2	200-400°F	5-15	120	1500	8

WATER BOIL-OFF HEATERS

- For use with 55-gallon steel drums only
- Features a 70-300°F thermostat range and a high limit cut off-switch that can be reset
- When water is reduced below the level of the heater the unit shuts off
- Plug type is NEMA no. 6-15
- 240 V, 3000 W, 6' power cord
- Weight: 14 lbs.

Model No. DA096



5-GALLON PAIL HEATERS

- Economy 5-gallon heater is suitable for use with plastic and metal pails
- For light duty applications like increasing flow of viscous fluids or heating water
- Aluminised construction
- Adjustable strap clamp allows heater to fit pails with straight or tapered sides from 9 1/2" to 12" in diameter
- 120 V, 100 W
- 6' power cord with standard three pin grounded plug
- Weight: 0.5 lb

Model No. DA074



PLASTIC DRUM HEATERS

- Specifically designed to heat materials contained in polyethylene drums or pails
- Pre-set bimetal thermostat is mounted directly on heating band; activated with on-off switch
- Heat delivered to drum does not exceed 165°F
- 9" wide heating band on 55-gallon model is double the width of standard heaters; increases heater surface area for a shorter heat-up time
- On-off indicator light
- 6' power cord



Model No.	Drum Cap. Gal.	Drum Dia. "	Plug Type NEMA No.	Volts	Watts	Wt. lbs.
DA080	5	11 1/4	5-15	120	100	7
DA081	55	22 1/2	5-15	120	800	15

VARIABLE CYCLE CONTROL HEATERS

- Designed to heat materials that have a tendency to burn or cook such as light oils, chemicals, food, and undercoating material
- Variable control cycles heat current on and off
- Ratio of 'time on' to 'time off' increases as setting switch is moved higher
- Cycling allows for a gentle heating of drum contents
- Three heat switch allows three wattage ratings per thermostat setting
- HIGH setting uses Max. Watts; MEDIUM, 1/2 Max. Watts; LOW, 1/4 Max. Watts
- Neon pilot light
- 6' power cord



Model No.	Drum Cap. Gal.	Drum Dia. "	Plug Type NEMA no.	Volts	Watts	Wt. lbs.
DA084	5	11 1/4	5-15	120	1500	5
DA082	16	14 1/2	5-15	120	1500	8
DA085	55	22 1/2	5-20	120	1750	15
DA086	55	22 1/2	6-15	240	3000	15

VALUE HEATERS

- Sturdy aluminised steel construction outlasts and outperforms all silicone rubber heaters
- 0-550°F adjustable thermostat offers wide flexibility when heating contents of 55 gallon, 22 1/2" diameter steel drums
- Heavy-duty, 5' grounded cordset plugs into standard 120 V outlets, 1250 W
- Weight: 8 lbs.

Model No. DA070



BONDING & GROUNDING WIRES

BONDING AND GROUNDING WIRE ASSEMBLIES DISSIPATE THE STATIC ELECTRICITY GENERATED DURING THE TRANSFER OF FLAMMABLE LIQUIDS.

VARIOUS CLAMP STYLES AVAILABLE TO WORK WITH DIFFERENT CONTAINERS. REQUIRED BY OSHA FOR FLUIDS WITH A FLASHPOINT BELOW 140°F.

HEAVY-DUTY ASSEMBLIES



TWO HAND CLAMP CONNECTORS

Model No.	Wire Length"	Wire Description
DA735	36	Stainless Steel
DA736	72	Stainless Steel
DA737	120	Stainless Steel



HAND CLAMPS & 1/4" TERMINAL CONNECTORS

Model No.	Wire Length"	Wire Description
DA738	36	Stainless Steel
DA739	72	Stainless Steel
DA740	120	Stainless Steel



HAND CLAMPS & PIPE CLAMPS (ADJUSTS 1/2"-1")

Model No.	Wire Length"	Wire Description
DA741	36	Stainless Steel
DA742	72	Stainless Steel
DA743	120	Stainless Steel

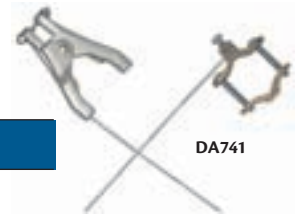

HAND CLAMPS & C-CLAMPS

Model No.	Wire Length"	Wire Description
-----------	--------------	------------------

SMALL C-CLAMPS (ADJUSTS TO 3/4")

DA744	36	Stainless Steel
DA745	72	Stainless Steel
DA746	120	Stainless Steel

LARGE C-CLAMPS (ADJUSTS TO 1 1/2")

DA747	36	Stainless Steel
DA748	72	Stainless Steel
DA749	120	Stainless Steel



LIGHT-DUTY ASSEMBLIES

ALLIGATOR CLIPS & 1" BEAM CLAMPS



Model No.	Wire Length"	Wire Description
DA621	36	Stainless Steel
DA750	72	Stainless Steel
DA751	120	Stainless Steel
DA623	36	PVC Coated
DA752	72	PVC Coated
DA753	120	PVC Coated

TWO ALLIGATOR CLIPS



Model No.	Wire Length"	Wire Description
DA622	36	Stainless Steel
DA754	72	Stainless Steel
DA755	120	Stainless Steel
DA756	36	PVC Coated
DA757	72	PVC Coated
DA758	120	PVC Coated

ALLIGATOR CLIPS & 1/4" TERMINAL CONNECTORS



Model No.	Wire Length"	Wire Description
DA759	36	Stainless Steel
DA760	72	Stainless Steel
DA761	120	Stainless Steel

ALLIGATOR CLIPS & SMALL C-CLAMPS



Model No.	Wire Length"	Wire Description
DA762	36	Stainless Steel
DA763	72	Stainless Steel
DA764	120	Stainless Steel
DA765	36	PVC Coated
DA766	72	PVC Coated
DA767	120	PVC Coated

TWO 1/4" TERMINAL CONNECTORS



Model No.	Wire Length"	Wire Description
DA768	36	Stainless Steel
DA769	72	Stainless Steel
DA770	120	Stainless Steel
DA771	36	PVC Coated
DA772	72	PVC Coated
DA773	120	PVC Coated

PIPE CLAMPS & LARGE C-CLAMPS



Model No.	Wire Length"	Wire Description
DA774	36	PVC Coated
DA775	72	PVC Coated
DA776	120	PVC Coated

PLIER CLAMPS

COIL CABLES

- Vinyl coated 1/8" cable resists corrosive environments to give years of service
- Unit is self-coiling to retract when not in use
- Includes one heavy-duty pliers-type clamp and one 1/4" terminal end

Model No.	Coil Length'
DA632	5
DA628	10
DA777	15
DB029	20
DA778	30



PLIER CLAMPS

- Grounding clamp for flammable drum loading
- Die cast aluminum body, stainless steel points and 55 lbs. spring enable REB clamp to consistently make positive metal to metal ground connection
- Accommodates all cable up to 5/32"; connection is made in clamp's handle held by dual Allen screw contacts



Model No. DA633

RETRACTABLE GROUNDING WIRES

- Replace loose/tangled grounding cables with compact retractable reels
- For use where a discharge of static electricity could cause a spark and subsequent explosion
- Positive latching mechanism holds cable at any length
- A slight pull on the cable releases the mechanism causing retraction
- Bearing surfaces are permanently lubricated
- Alligator clip included
- Heavy-duty reels have robust, weatherproof construction and coated cables
- Functions under extreme environmental conditions

DB025

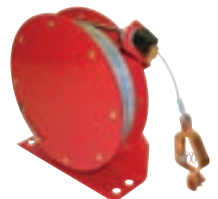

DA609



Model No.	Description	Length'
DA609	Light Duty	20
DA610	Light Duty	50
DB025*	Heavy-Duty	50
DB026*	Heavy-Duty	75
DB027*	Heavy-Duty	100

* Open style

DRUM PUMPS

BEFORE ORDERING ANY PUMP, ESTABLISHING COMPATIBILITY WITH THE MSDS OF THE FLUID USED IN APPLICATION IS A MUST! BOND/GROUND CABLES ON PAGE B127 ARE REQUIRED WHEN PUMPING FLAMMABLE OR COMBUSTIBLE LIQUIDS.

STAINLESS STEEL PULL TYPE PUMPS

Model No. DA530

- Use with certain acids and alkalis
- Fits 5 to 55-gallon drums with a 2" bung adaptor
- Transfer rate: 8 oz. per stroke
- **Wetted components:** 304 stainless steel, brass, polyethylene and steel

Model No. DA531

- For most acids and corrosives
- Fits 5 to 55-gallon drums with a 2" bung adaptor
- Transfer rate: 8 oz. per stroke
- **Wetted components:** 304 stainless steel, 316 stainless steel, brass and Teflon

Model No. DA529

- For fast transfer of most acids and corrosives
- Fits 55-gallon drums with a 2" bung adaptor
- Transfer rate: 22 oz. per stroke
- **Wetted components:** 304 stainless steel, polyethylene and Teflon

Model No. DB845

- For fast transfer of most acids and corrosives
- Fits 55-gallon drum with a 2" bung adaptor
- Transfer rate: 22 oz. per stroke
- **Wetted components:** 304 stainless steel, 316 stainless steel and Teflon

KLETON



STEEL PULL TYPE PUMPS

Model No. DA527

- For most non-corrosive and non-flammable liquids
- Fits 5 to 55-gallon drums with a 2" bung adaptor
- Transfer rate: 8 oz. per stroke
- **Wetted components:** Brass, steel and polyethylene

Model No. DC113

- For most water-soluble inorganic acids, waxes, detergents
- Fits 5-gallon pails with a 2" bung adaptor
- Transfer rate: 8 oz. per stroke
- **Wetted components:** Buna-N, polyethylene, leather and steel

Model No. DC114

- Use with most non-corrosive, light to medium viscosity liquids
- Fits 55-gallon drums with a 2" bung adaptor
- 3/4" diameter spout can be rotated to 180° and removed to expose garden hose thread
- Transfer rate: 22 oz. per stroke
- **Wetted components:** Polyethylene, steel and zinc

KLETON



PVC PULL TYPE PUMPS

Model No. DC116

- For use with most mild acids, detergents, water and solvents
- Good insulation from spark and fire
- Adapts to 3/4" or 2" for 5 to 55-gallon drums
- Transfer rate: 8 oz. per stroke
- **Wetted components:** Polypropylene, polyethylene, PVC and silicone

KLETON



POLYPROPYLENE PULL TYPE PUMPS

Model No. DC127

- For use with most antifreeze, detergents, windshield fluids, glycerin, and mild acids
- Fits 15 to 55-gallon drums with 2" bung adaptor
- Transfer rate: 14 oz. per stroke
- **Wetted components:** Polypropylene, steel and Vitor

Model No. DC117

- For use with most corrosive chemicals, water, and non-flammable solvents
- Good insulation from spark and fire
- Fits 55-gallon drums with a 2" bung adaptor
- Transfer rate: 22 oz. per stroke
- **Wetted components:** Polyethylene, polypropylene, silicone and steel

KLETON



NYLON PULL TYPE PUMPS

Model No. DC128

- For use with most lacquer thinners, mild acids, detergents, water and light viscosity petroleum liquids
- Fits 15 to 55-gallon drums with 2" bung adaptor
- Transfer rate: 14 oz. per stroke
- **Wetted components:** Polypropylene, nylon, 304 stainless steel and Teflon

KLETON



ENVIRO-WEDGETM

The *Enviro-Wedge™* increases the amount of product pumped out of 25-45 gallon drums. When the drum is nearly empty tilt it on an angle and position the wedge under the drum. Continue pumping until flow stops. 100% recycled, rugged polyethylene construction. Wt. 1.5 lbs.

Model No. DA660



LEVER TYPE PUMPS

- Use with most water-based solvents, strong acids or alkalis and light viscosity petroleum liquids
- Fits 5 to 55-gallon drums
- with a 1 1/2" or 2" bung adaptor
- Transfer rate: 14 oz. per stroke

Model No. DC122



LEVER TYPE PUMPS

- Use with certain water-based solvents, strongest acids or alkaline solutions
- Fits 5 to 55-gallon drums
- with a 1 1/2" or 2" bung adaptor
- Transfer rate: 14 oz. per stroke

Model No. DC123



HEAVY-DUTY PLASTIC LEVER PUMPS

- Self-priming, constructed of engineered polypropylene
- Telescoping suction tube is designed for dispensing oil type fluids from 15 and 55-gallon drums and storage tanks
- Feature a discharge of 1 quart per three downstrokes through an anti-drip nozzle having a pump alignment of 360°



POLYPROPYLENE LEVER PUMPS

- Delivers approximately 10 ounces per stroke with a capability of 6 gallons per minute
- Manufactured of the highest quality polypropylene
- Will handle viscous materials equivalent to SAE #90 oil; also compatible with most acids, caustics and other mild liquids
- 2" bung adaptor and telescoping extension tube for use with 5 to 45-gallon drums
- 360° discharge spout orientation
- EPDM O-Rings

Model No. DA534



Model No.	Lever Pump Seal	Wt. lbs.
DA518	Buna-N (Nitrile)	3.1
DA686	Viton® Seal	3.1
DA687	EPDM Seal	3.1

NYLON PUMPS

- Manufactured from heavy-duty nylon, this non-drip pump can handle all viscosities from paraffin to gear oil
- Viton® seals
- Discharge rate of 26 gallons per 100 strokes
- Self priming and venting foot valve ensures greater longevity of moving parts and a minimum level of maintenance
- Detachable spout allows for discharge hose adaptability
- Dual thread 2" bung adaptor for plastic and steel drums

Model No. DA533



SAFETY PUMPS

- Constructed of highly polished carbon steel with Teflon® piston, packing and gasket for exceptional chemical and solvent resistance
- Steel pickup tube with internal screen keeps debris out of pump
- Pumps 8 oz. per stroke, designed to fit 45-gallon drums
- Comes complete with internal flame arrestor, steel bung adaptor to aid static grounding, and heavy duty bonding wires to remove hazardous static charge
- FM approved for handling flammables
- Also available in stainless steel for corrosive flammable liquids

Model No. DA513 Carbon Steel

Model No. DB831 Stainless Steel



PAIL TYPE PUMPS

- Use with most engine oils, gear oils, and antifreeze
- Fits 5 gallon drums with a 2 1/4" bung adaptor
- Includes a 48" discharge hose fitted with curved metal spout at discharge end
- Transfer rate: 2 oz. per stroke

Model No. DC129



POLYETHYLENE SIPHON PUMPS

- Use with most water based liquids, light oils and detergents
- Air vent in handle controls flow
- Fits 15 to 55-gallon drums with 2" bung adaptor
- Transfer rate: 7 gallons/minute

Model No. DC119



ACID TRANSFER PUMPS

- Designed to transfer most acids
- Body and shaft are constructed of a special polyvinyl chloride with the valves and patented seal of DuPont®'s Viton®
- Intake tube is 38" long and 1 1/2" dia.
- Flow rate is 28 oz. per stroke
- Complete with 3' polyethylene discharge tubing

Warning: Not compatible with most alkalis, acetic acid (30%), hydrofluoric acid and methyl alcohol

BECKSON

Model No.	Adaptor Style
DA810	Std. 2" IPS Bung



ALKALI TRANSFER PUMPS

- Designed to transfer detergents, waxes, alkalis and certain acids
- Body and shaft are constructed of a special polyvinyl chloride with the valves and seals of DuPont® Hypalon®
- Intake tube is 38" long and 1 1/2" dia.
- Flow rate is 28 oz. per stroke
- Compatible with most alkalis, hydrofluoric acid, acetic acid (30%) and methyl alcohol
- Complete with 3' polyethylene discharge tubing

BECKSON

Model No.	Adaptor Style
DA811	Std. 2" IPS Bung



PETROLEUM DRUM PUMPS

- Designed to transfer petroleum products
- Body and shaft are constructed of a special polyvinyl chloride with valves of polyurethane, seals of Buna-N and a reinforced vinyl hose
- Intake tube is 38" long and 1 1/2" dia.
- Flow rate is 28 oz. per stroke
- Compatible with petroleum products
- Complete with 3' vinyl discharge tubing

BECKSON

Model No.	Adaptor Style
DA812	Std. 2" IPS Bung



DRUM PUMPS

BEFORE ORDERING ANY PUMP, ESTABLISHING COMPATIBILITY WITH THE MSDS OF THE FLUID USED IN APPLICATION IS A MUST! BOND/GROUND CABLES ON PAGE B127 ARE REQUIRED WHEN PUMPING FLAMMABLE OR COMBUSTIBLE LIQUIDS.

ROTARY DRUM PUMPS

POLYPROPYLENE

- For most water-soluble inorganic acids, waxes, detergents
- Fits 15 to 55-gallon drums with a 2" bung adaptor
- Transfer rate: 12 oz. per revolution
- **Wetted components:** 304 stainless steel, polypropylene, Teflon[®] and Viton[®]

Model No. DB998



RYTON[®] & STAINLESS STEEL

- Use with most aggressive chemicals such as hydrocarbons and ketones
- Fits 15 to 55-gallon drums with a 2" bung adaptor
- Transfer rate: 12 oz. per revolution
- **Wetted components:** 304 stainless steel, polypropylene, Ryton[®] and Teflon[®]

Model No. DC335



#304 STAINLESS STEEL

- For most organic acids, alcohols and solvents
- Fits 15 to 55-gallon drums with a 2" bung adaptor
- Transfer rate: 12 oz. per revolution
- **Wetted components:** 304 stainless steel and Teflon[®]

Model No. DB759



TEFLON[®]

- For most aggressive chemicals such as acids and alkalines
- Fits 30 to 55-gallon drums with a 2" bung adaptor
- Transfer rate: 12 oz. per revolution
- **Wetted components:** Hastelloy[®] and Teflon[®]

Model No. DC334



STEEL & CAST IRON

- For use with most medium viscosity petroleum fluid, light non-flammable and non-combustible fluids
- Dual directional operation allows pump to both empty and refill containers
- Fits 30 to 55-gallon drums with a 2" bung adaptor
- Transfer rate: 8 oz. per revolution
- **Wetted components:** Buna-N, cast iron, polyethylene, polypropylene and steel

Model No. DA528



ALUMINUM

- Use with most medium viscosity petroleum fluid, and non-corrosive fluids
- Fits 15 to 55-gallon drums with a 2" bung adaptor
- Transfer rate: 12 oz. per revolution
- **Wetted components:** Aluminum, Buna-N, polypropylene and steel

Model No. DC112



ALUMINUM

- Use with most low viscosity, non-corrosive petroleum based fluids and lubricating oils up to SAE30
- Fits 15 to 55-gallon drums with a 2" bung adaptor
- Transfer rate: 6.75 oz. per revolution
- Includes a safety locking latch
- **Wetted components:** Aluminum, Buna-N, PVC nitrile, steel and zinc

Model No. DC126



DRUM PUMPS

Chemical compatibility of a drum or barrel pump should be checked for EACH LIQUID BY CHEMICAL NAME!

No single drum pump can be universally chemical resistant. Some blends of chemicals may not be suitable for any of these drum pumps. Remember to have your MSDS for each chemical that will be pumping when calling your representative. We will be able to help you select the right pump for your application.

POLYPROPYLENE PULL TYPE PUMPS

Model No. DC115

- For use with most corrosive chemicals and non-flammable solvents
- Fits 5 to 55-gallon drums with 3/4" or 2" bung adaptor
- 360° discharge spout orientation
- Transfer rate: 16 oz. per stroke
- **Wetted components:** Polyethylene, polypropylene, silicone and steel

KLETON



Model No. DA532

- Use with most corrosive chemicals and non-flammable solvents
- Fits 5 to 55-gallon drums with 3/4" or 2" bung adaptor
- 360° discharge spout orientation
- Transfer rate: 8 oz. per stroke
- **Wetted components:** Polypropylene, polyethylene, silicone and steel



DIAPHRAGM HAND PUMPS

- For petroleum fuels, light lubrication oils, and water-based solutions
- Fits 15 to 55-gallon drums with 2" bung adaptor
- Transfer Rate: 25.5 oz. per stroke
- Includes a safety locking latch
- **Wetted components:** Aluminum, Buna-N, Delrin[®], 304 stainless steel and steel

Model No. DC068

KLETON



TRANSFER PUMPS

- Non-corrosive, double action piston pump is designed to handle most petroleum products, solvents and industrial chemicals with viscosities up to 2000 SSU
- Discharges 1 quart per stroke with a suction lift to 15'
- Thermoplastic constructed pump has a polyester glass reinforced body, Viton[®] "O" ring and cork-nitrile gasket
- All internal metal parts in contact with liquid are 316 stainless steel
- **Includes:** 8' PVC black vinyl discharge hose, 2-piece 1" x 34" L polyester suction tube, polyester discharge spout and 2" bung adaptor

Model No. DA526



DRUM HAND TRUCKS

- All welded, 1 1/4" round tubular steel frame
- Handles steel drums from as small as 18" to 25" in diameter
- Ideal for loading drums onto pallets, or for going over curbs or uneven docks
- Free standing when loaded
- Capacity: 1000 lbs.
- Durable *Kleton* blue enamel finish



DA594



Model No.	Description	Overall Dim. W" x D" x H"	Wt. lbs.
DA593	w/10" Front Rubber Wheels Only	24 x 19 x 58	44
DA594	w/10" Front and 6" Rear Rubber Wheels	24 x 22 x 58	50

DRUM HAND TRUCKS FOR PLASTIC & FIBRE DRUMS

- All welded, 1 1/4" round tubular steel frame
- Handles plastic and fibre drums from 18" to 25" in diameter and 24" to 41" in height
- Rolls on 10" front and 6" rear rubber-tired wheels
- 2" ratchet strap secures drum in place
- Dimensions: 23" W x 24" D x 58" H
- Weight: 56 lbs. • Capacity: 800 lbs.
- Durable *Kleton* blue enamel finish

Model No. DA595



ALL-IN-ONE DRUM TRUCKS

- All welded, 1 1/4" round tubular steel frame
- Drum trucks can be used to transport and dispense drums
- Easy-to-use belt-system and hook keeps drums securely on the truck
- Easy to load and unload on skids
- Handles plastic, steel or fibre drums
- Loop handle models provide added leverage while dual handle models provide side body comfort
- Four wheel design for added support and easy manoeuvrability
- Capacity: 1000 lbs.
- Durable *Kleton* blue enamel finish



Retaining hook

DC266



DC256



Model No.	Handle Type	Wheel Type	Wt. lbs.
DC266	Loop	10" Mold-On Rubber	64
DC267	Loop	10" Pneumatic	58
DC256	Dual	10" Mold-On Rubber	62
DC257	Dual	10" Pneumatic	56

ALUMINUM FRAME DRUM TRUCKS

- Static free for use around volatile materials
- Ideal when the truck itself must be lifted or transported
- Rear wheels act as a pivot to raise truck onto curbs or pallets
- Automatic, spring-loaded chime hook engages rim of 25 or 45-gallon steel drums quickly and safely
- 10" x 2 1/2" solid rubber tires
- Hand brake on **DA586** is designed to slow down or stop both load carrying wheels whenever necessary
- Gives operator complete control of truck, even on ramps or inclines
- Capacity: 1000 lbs.



Model No.	Description	Wt. lbs.
DA582	Without Brake	48
DA586	With Hand Brake	52



DA586

ERGONOMIC DRUM TRUCKS

- Floating axle reduces effort required to break over and balance load
- Chime hook can be stored at the top of the frame for easy use
- Replaceable hard faced double beveled nose prongs
- Handles steel drums only
- 10" mold-on rubber wheels
- Overall dimensions: 17 1/2" L x 23 3/4" W x 61" H
- Capacity: 1000 lbs.
- Weight: 74 lbs.

Model No. DC417



SINGLE BAR DRUM TRUCKS

- Handles 45 gallon steel drums
- Heavy-duty 1" structural pipe frame with double welded joints
- Machined steel load wheels behind nose prongs help ease lifting of drum
- Classic single bar frame design
- Kickstand and vinyl handle grips included
- Available with cast iron centre *Mold-On* rubber wheels with 1" (ID) roller bearings or polyolefin wheels
- 24" wide at handle, 16 1/4" wide at nose
- Capacity: 1000 lbs.



Model No.	Wheel Type	Wt. lbs.
DA883	Polyolefin	50
DA882	Mold-On Rubber	64



MULTI-PURPOSE STAINLESS STEEL DRUM TRUCKS

- Handles heavy drums, loads and unloads pallets, and functions as a high capacity drum dispenser
- For use with 70 imperial gallon salvage or overpack drums, 25 and 45 gallon steel drums and most 25 and 45 gallon plastic drums
- Extra long U-shaped handle provides added leverage when loading and moving heavy drums
- 63" L x 19 1/2" W frame allows easy access through narrow aisles
- Self-supporting for draining
- Four 8" *Mortuf* wheels with roller bearings allow truck to travel a straight line and permit easy steering around corners with minimal effort
- All-welded, type 304 stainless steel construction
- Capacity: 1000 lbs.



Model No.	Wheel Type	Wt. lbs.
DA581	<i>Mortuf</i>	63



DRUM SPOTTERS

- Moves drums to and from pallets easily across floors, effectively and efficiently
- Designed for 45 gallon steel or plastic drums with various rims and most fibre drums with clamp-on lids in a size range of 22" to 23 1/2" diameter and 34 to 36" high, weighing up to 800 lbs.
- Features two forged lifting hooks which slide under the top rim of drum
- Handle provides adequate leverage to lift heavy drums
- Base has built-in counterweight for stability
- Features two 6" polyolefin load wheels and two 4" rear swivel caster for easy steering

Features:

- Simple to operate
- Compact
- Holds drums upright
- No power truck required
- Self-supporting
- No balancing required

Model No.	Lifting Capacity lbs.	Max. Pallet Height"	Wt. lbs.
DA933	800	6	145



DRUM HANDLERS

DRUM ROCKERS

- All welded, 1 1/4 round tubular steel frame
- No lifting, straining, or danger of drum tipping backwards
- Removable handle
- 3" polyolefin wheels and swivel casters
- Capacity: 1000 lbs.
- Durable Kleton blue enamel finish



DC442

Model No.	Description	Wt. lbs.
DC442	Two 3" Swivel Casters, Two 3" Wheels	38

KNOCKED DOWN DRUM ROCKERS

- Safe method for moving, draining and storing 55-gallon drums
- Two 3" non-sparking wheels and two 3" non-sparking swivel casters
- Removable handle
- Capacity: 700 lbs.
- Powder coat finish
- Shipped knocked down

Model No. DC443



MOBILE DRUM CARRIERS

- Transports, rotates, tilts and drains fully loaded drums up to 800 lbs.
- Drum can be raised to a floor clearance of 5 1/8" to 11 1/2", automatically sets lock
- Tilt lock on each side of unit
- All-welded steel constr
- 8" polyolefin wheels and 4" swivel caster
- Weight: 106 lbs.



MORSE

Model No.	Drum
DA189	45-Gallon Steel; 22 1/2" Dia.
DA190	45 Gallon Plastic and Steel; 22 1/2" - 24" Dia., 34" - 36" H
DA191	25 and 45 Gallon Steel; 18 1/2" - 19" and - 22 1/2" Dia.
DA192	21" - 23" Dia. Fibre and Steel
DA193	25 and 45 Gallon Fibre and Steel; 18 1/2" - 19" and - 22 1/2" Dia.

LIL'DOLLY™ PAIL DOLLIES

- Designed for use in hospitals, food processing plants, manufacturing locations, hotels, restaurants and anywhere
- 5, 6 and 15-gallon pails are used
- Five dual wheel swivel stem casters
- Inside diameter: 11"
- Capacity: 75 lbs.
- Weight: 2 lbs.

Model No. MD527



LOW PROFILE DRUM TRUCKS

- All welded, ready to use
- With a low-level frame, only 1" from the ground, allows for easy loading of drums
- Hinged handle moves forward and backward
- 8" x 2" rubber wheels and 4" resilient non-marking swivel casters
- Handle length: 37"
- O. A. Dimensions: 31" W x 28" D x 45" H
- Capacity: 1000 lbs.
- Weight: 35 lbs.
- Durable Kleton blue enamel finish

Model No. DA579



STEEL DRUM DOLLIES

- Welded 3/16" thick x 4", frames are built to withstand constant use
- 24" inside diameter handles 45-gallon drums
- Comes with four swivel casters
- Quality powder-coat finish
- Caster assembly required

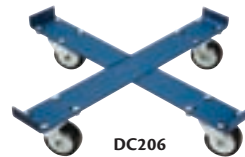

DC206



DC202



Model No.	Caster Type	Caster"	Height"	Capacity lbs.	Wt. lbs.
ROUND FRAME					
DC202	Polyolefin	3	4 1/2	750	21
DC199	Polyurethane	3	4 1/2	1000	24
DC200	Polyurethane	4	5 1/2	1500	27
DC070*	Frame Only	-	-	-	16
X-FRAME					
DC206	Polyolefin	3	4 1/2	750	13
DC203	Polyurethane	3	4 1/2	1000	16
DC204	Polyurethane	4	5 1/2	1500	19
DC071*	Frame Only	-	-	-	8

* Fits Caster Hole Spacings of 1 5/8" x 3" to 2 3/4" x 3 1/4"

CLAMP & GO DOLLY HANDLES

- Safely and easily maneuver drum within confined areas
- Perfect for high volume applications
- Low center of gravity provides superior stability
- Quickly clamps onto dollies with various sidewalls of 2", 2 1/2" or 3"
- Foot operated disengage
- Magnet holds handle up to drum for compact storage
- Weight: 11 lbs.

Model No. DC414

MORSE



LEAK CONTAINMENT DRUM DOLLY

- Polyethylene dolly will not dent, corrode or rust
- Handles 45-gallon drums
- Solid bottom construction with a 2" lip contains spills up to 5 L
- Overall diameter: 24 1/4"
- Capacity: 1000 lbs.
- Grey

ZENITH
Safety Products



Model No.	Caster Type	Caster"	Height"
DC465	Polyurethane	3	6 1/4
DC466	Polyolefin	3	6 1/2
DC467	Polyolefin	4	7 1/4



CUSTOMISE IT TO YOUR SPECIFICATIONS.
See page B60 for details

DRUM/OVERPACK LIFTERS

- A safe method of moving 45 gallon steel drums
- Design allows for quick, gentle loading, drum stays upright during lift
- Low-profile clamp design on 45 gallon lifter lowers open (lid must be on) or closed head steel drums all the way to bottom of overpack
- 70 gallon overpack lifter picks up both 70 gallon steel overpack drums and 45 gallon steel drums
- Universal **DA876** handles many lever-lock closure fibre drums, typical steel drums and 45 gallon rimmed plastic drums
- Capacity: 1000 lbs.

Model No.	Description	Wt. lbs.
DA224	45 gal. Lifter	21
DA225	70 gal. Overpack/45-gal. Lifter	22
DA876	Universal Lifter	25
DC094	Stainless Steel Universal Lifter	25



AUTOMATIC VERTICAL DRUM LIFTERS

- Lifts and transports closed steel drums easily and effectively
- Unit grips automatically; releases only when drum is set down
- Operator does not have to be at pick up or drop points
- 45-gallon model is available in standard steel or type 304 stainless steel construction
- Capacity: 1000 lbs.



MORSE

Model No.	Lifts Drum Size Gallons	Construction Material	Wt. lbs.
DC091	30	Steel	45
DA203	45	Steel	50
DC092	45	Stainless Steel	50
DC093	85	Steel	59

DRUM LIFTERS

BELOW-HOOK

- Designed for steel, plastic and fibre drums with diameters between 22" to 23 1/2" and heights between 23" to 38"
- Attaches to a monorail, crane or chain block and transports loaded drums in the upright position
- Drum is secured into the saddle by a pawl and ratchet mechanism
- Saddle, as well as the support bar at the bottom of the drum, ensures that drums will be transported safely, restraining the drum from sliding out
- Accepts diameter adaptors for smaller drums



Model No.	Lifting Capacity lbs.	Wt. lbs.
DA935	1000	61

MORSE

POLYESTER DRUM SLING

- Securely and economically lifts steel, plastic and fibre drums from 12" to 24" in diameter
- Ideal for use with a forklift truck
- Compact size of slings allows it to be stored in truck until it's needed
- Reduces drum damage which occurs when using steel handlers
- 2" x 10' endless ratchet strap tightens the reinforced polyester lifting belt around the body of the drum
- 4" x 6' double ply tie down web slips easily over the truck forks
- Capacity: 1000 lbs.
- Wt.: 5 lbs.



Model No. DC470

Note: Open ratchet fully when installing sling

MULTI-PURPOSE OVERHEAD DRUM LIFTERS WITH WRENCHES

- Simple three-arm design allows for safe lifting of closed head 30 to 55-gallon steel, plastic, and fibre drums with top lips
- Each removable arm also functions as a wrench for use on different drum plugs, faucets, and rim ring bolts.
- Lifts drums up to 800-lb. capacity
- Powder coat finish for durability
- Weight: 20 lbs.

Model No. DC095

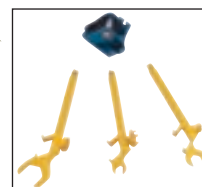

HORIZONTAL DRUM LIFTING HOOKS

- Horizontally lifts 45 gallon steel drums, 34"- 36" long
- Alloy steel lifting ring, steel rods, malleable iron hooks
- Capacity: 1000 lbs.
- Weight: 5 lbs.

Model No. DC449

- Spark resistant lifting hook is made of bronze and stainless steel for safe handling
- Capacity: 1000 lbs.
- Weight: 5 lbs.

Model No. DA163



DA163



DC449

AUTO-GRIP DRUM LIFTERS

- Easy, no-tilt lifting of rimmed steel drums
- Self-energizing: the heavier the load, the tighter the grip
- Attaches to any hoist, crane or forklift using single fork hook attachment
- Heavy-duty, annealed, ductile iron construction
- Large curved foot at bottom of stabilising arm prevents drum damage
- Capacity: 3000 lbs.
- Wt.: 31 lbs.

Model No. DA226



OPEN HEAD DRUM LIFTERS

- Quick and easy attachment and removal
- Suitable for use with standard steel or poly drums with at least a 3/16" chime
- Lifting arms are adjustable to work with most 55 or 30-gallon drums
- Attaches to any hoist, crane or forklift using single fork hook attachment
- 3-point contact of the lifting arms minimizes deformation
- Also works on closed head drums
- Capacity: 1000 lbs.
- Weight: 15.5 lbs.

Model No. DC420



DRUM LIFTERS & HANDLERS

STEEL SINGLE DRUM GRABBER

- Lift and transport one 55-gallon steel drums without the fork truck driver leaving his seat
- No risk of drum slipping since handler grips under rim of drum or rolling hoops
- Heavy gauge grabber slides onto truck forks and locked with two turn down screws

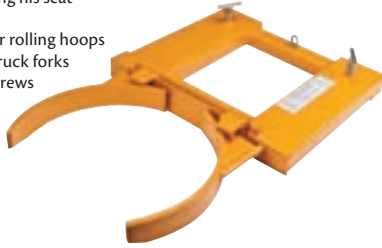

KLETON

Model No.	Fork Pocket Inner Dia."			Capacity lbs./Drum	Wt. lbs.
	W"	x	H"		
DC424	5 1/2	x	2	1000	121

STEEL DOUBLE DRUM GRABBER

- Lift and transport two 55 US-gallon steel drums without the fork truck driver leaving his seat
- No risk of drum slipping since handler grips under rim of drum or rolling hoops
- Heavy gauge grabber slides onto truck forks and is locked with 2 turn down screws



WESCO

Model No.	Fork Pocket Inner Dia.		Capacity lbs./Drum	Wt. lbs.
	W"	x H"		
DC039	7	x 2.25	1,000	198

GATOR GRIP™ FORKLIFT ATTACHMENTS FOR DRUM HANDLING

- Handles steel, plastic and fibre drums
- Patented auto grip lock automatically locks the jaws closed, even over rough terrain
- Adjustable for 30, 50 and 80 US gallon drums
- T-handles fasten safety to any forklift
- Can be used with open or closed head drums
- Capacity: 1000 lbs. per grip

Applications: Shipping, receiving, loading, racking and palletizing



DC268



DC269

WESCO

Model No.	Description	Overall Dimensions			Wt. lbs.
		W"	x D"	x H"	
DC268	Single Drum Handler	28	x 34	x 34	126
DC269	Dual Drum Handler	33 1/4	x 34	x 34	208

GRAVITY-ACTUATED MECHANICAL AUTO-GRIP™

- Most efficient on consistently-sized loads
- Equipped with standard jaws only that grip with pressure equal to the weight of the drum and adjusts to fit 30, 55 or 85 gallon steel, fibre or overpack drums
- Adjusts to grasp any cylindrical object 18-28" in diameter
- Spring-and-cam actuated jaws automatically grip while engaging drum
- Jaw dimensions: 3" x 15"
- Fork tube dimensions: 1 5/8" x 5 5/8" x 20"
- Distance between forks is 19 1/2"
- Capacity: 1500 lbs.



Model No. DA175



VALLEYCRAFT
ALL IN A DAY'S WORK

GRAVITY-ACTUATED MECHANICAL AUTO-GRIP™

- Exclusively designed for use with 55 gallon plastic drums
- 3" jaws fit snugly under top rim of full or empty plastic drums
- Turnbuckle mechanism adjusts to grasp any cylindrical object 22-24" in diameter
- Spring-and-cam actuated jaws automatically grip while pressure of the drum forces them down
- Jaw size: 3" x 15"
- Fork-mounted to easily attach and unattach from forklift in seconds
- Fork tube dimensions: 1 1/8" x 5 5/8" x 20"
- Distance between forks: 19 1/2"
- Capacity: 1000 lbs.

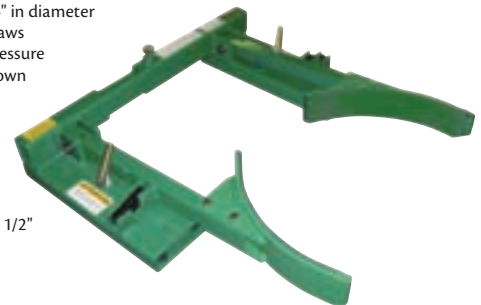

Model No. DC014

VALLEYCRAFT
ALL IN A DAY'S WORK

POLY DRUM LIFTERS



WESCO

- Patented fork truck attachment for handling most 55 and 30 US gallon poly drums
- Fork truck driver does not have to leave cab to engage or disengage drum
- Suited for poly drums that have at least a 3/16" top lip (chime)
- Fork pocket dimensions: inside 1 1/2" x 5 3/8"
- Capacity: 1000 lbs.
- Shipped knocked down

Model No. DA932

DRUM LIFTERS & HANDLERS

GATOR GRIP™ ERGONOMIC DRUM HANDLERS

- Handles steel, plastic and fiber drums
- Patented *Auto Grip™* lock automatically locks the jaws closed, even over rough terrain
- Ergonomic solution for lifting, transporting and placing drums on standard pallets or spill pallets
- The jaw clamp is spring loaded and can hold any 3/16" or higher drum rim
- Adjustable for most standard 30, 55 and 85 gallon drums
- Allows a 55 gallon drum to be raised 20" above the floor
- Rolls smoothly on swivel casters which provide easy steering and include a floor lock
- Overall dimensions: 34 1/2" L x 36" W (legs retracted), 37" L x 41" W (legs extended)
- Capacity: 1100 lbs.
- Weight: 356 lbs.

Model No. DC270



FORK MOUNTED DRUM LIFTERS

- Allows operator to raise, transport, tip and drain loaded drums without leaving their seat
- Geared design with pull chain
- Manipulation of pull chain for 360° rotation
- Attaches easily to truck by sliding onto forks and tightening screw locks
- 6 1/2" W x 30" D x 2 1/2" H fork pockets; inside width between truck forks must be at least 24 1/2"
- Options are available to handle plastic, fibre, and steel drums
- 22 1/2" diameter



Controlled pouring up to 2000 lbs.

Model No.	Drum Gallons	Tilt Type	Full Drum Cap. lbs.	Half Drum Cap. lbs.	Wt. lbs.
DA133	45	Geared	800	500	169
DA135	45	Geared	1500	800	178
DA134*	45	Geared	2000	1000	361

* Can only be used with diameter adaptor DC281

Note: Battery-powered option available

DRUM LIFTERS

Safely transport, position and drain open and closed head steel drums. Simply attach the lifter on hook of chain block, monorail or crane, cinch saddle around drum, and then raise to the required height and position. Ratchet mechanism securely tightens saddle to drum. Choice of manual or geared models.

A. MANUAL TILT

- Ideal for low level pouring and dumping operations
- 800-lb. full drum capacity, 500-lb. half drum capacity
- Tilt lock on each side of hanger frame is used to secure drum in a vertical or horizontal position



Model No.	Drum Size	Wt. lbs.
DA199	45 Gallon Steel; 22 1/2" Dia.	46
DA200	25 and 45 Gallon Steel; 18 1/2" - 19" and 22 1/2" Dia.	46
DA201	21" - 23" Dia. Fibre or Steel	46
DA202	25 And 45 Gallon Fibre and Steel; 18 1/2" - 19" and 22 1/2" Dia.	46

B. GEARED TILT

- Accurate pouring from any height
- Handles drums up to 2000 lbs. full drum capacity
- Rotation of drum is controlled by 6' chain loop
- Optional MORStop™ tilt brake holds drum tilt position constant even when tension from the pull chain is removed

Model No.	Drum Size	Full Drum Cap. lbs.	Half Full Cap. lbs.	Wt. lbs.
DA121*	45 Gallon Steel; 22 1/2" Dia.	800	500	71
DA124*	45 Gallon Steel; 22 1/2" Dia.	1500	800	85
DA123**†	45 Gallon Steel; 22 1/2" Dia.	2000	1000	170
DA126	25 Gallon Steel; 19" Dia.	1500	800	90

OPTION

DC077 MORStop™ Tilt Brake Option

* Chains can be guided into locking slots to hold the drum's position, allowing the operator to let go

** Worm gear speed reducer on DA123 tends to let drum stay where it is stopped

† Can only be used with diameter adaptor DC281

B. Geared Tilt



DRUM HANDLERS & RACKS

DRUM STACKING RACKS

- Rack holds two or three 55 gallon drums
- Can be stacked up to three high
- Conveniently stacks drums horizontally increasing space efficiency
- Forklift access from all four sides
- Shipped knocked down

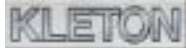

Model No.	O.A. Dimensions W" x D" x H"	Drum Cap.	Load Cap.	Wt. lbs.
DC262	45 1/2 x 30 x 12 1/2	2	1600	48
DC263	71 1/2 x 30 x 12 1/2	3	2400	75

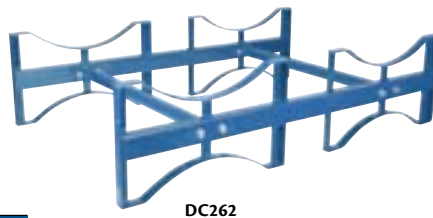

DC262



Drums not included

OPTIONAL DOLLIES

- All welded, ready to use
- Dolly allows stacking racks to be mobile
- Two rigid and two swivel casters
- Durable Kleton blue enamel finish
- Caster assembly required

Model No.	Wheel Type	Overall Dimensions W" x D" x H"	Capacity lbs.
DC392	6" Hi-Temp Nylon	30 x 46 x 9	1600
DC393	6" Polyurethane	30 x 46 x 9	1600
DC394	6" Hi-Temp Nylon	30 x 72 x 9	2400
DC395	6" Polyurethane	30 x 72 x 9	2400

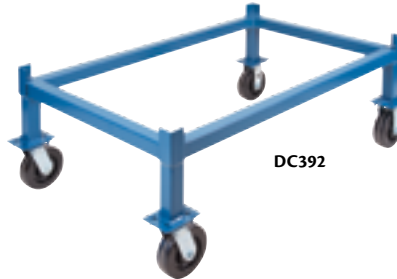

DC392

Use dollies with DC262 and DC263



ML861



ML400

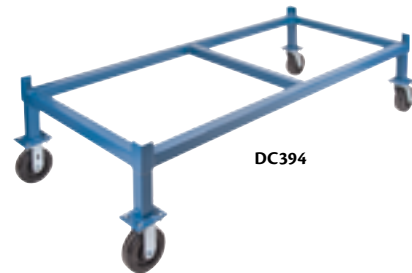

DC394

REPLACEMENT CASTERS

Model No.	Description
ML861	6" Hi-Temp Nylon Swivel Caster
ML862	6" Hi-Temp Nylon Rigid Caster
ML399	6" Polyurethane Swivel Caster
ML400	6" Polyurethane Rigid Caster

HYDRA-LIFT DRUM HANDLERS

- A safe way to lift, move, tilt and drain 45 gallon drums
- Manual control; pump-handle lifts drum, maximum extension is 45 strokes
- Hand crank controls tilt angle of drum up to 360° in either direction for controlled pouring of contents, chain wheel controls tilt for 72" and higher lift models
- 800-lb. full drum capacity; 500-lb. half-full capacity
- Rugged, heavy-duty welded frame; 8" polyolefin wheels and 4" swivel casters; screw-down floor lock
- Power lift and power tilt with a choice of motors is optional
- Shipped partially disassembled
- Powered models eliminate the manual effort of drum raising and tilting; increases productivity and safety
- Optional MORStop™ tilt brake holds drum tilt position constant even when tension from the pull chain is removed

MANUAL LIFT - For the 60" dispensing height unit, the tilt function is controlled by a hand crank. The 72" and 96" tilt control is with a chain wheel.

POWER LIFT - Moving valve handle to up, down or hold position controls drum height; 25 second lifting time.

POWER LIFT & TILT - One valve controls lifting, another controls tilt angle. Ideal when hand crank or chain drop is out of reach.

Dispensing Height"	H"	L"	O.D."	I.D."
60	55	60	44	37
72	55	60	44	37
96	69	76 1/2	50	43

Dispensing Height			
60"	72"	96"	
Model No.	Model No.	Model No.	Description
DA138	DA143	DA153	Manual Hydra Lift & Tilt
DA139†	DA144†	DA154†	Hydra Lift C/W Air Power Lift & Power Tilt
DA141†	DA146†	DA156†	Hydra Lift C/W Air Power Lift and Manual Tilt

OPTION

DC077 MORStop™ Tilt Brake Option

* Filter, regulator, lubricator and valve not included

† MORStop™ tilt brake option not needed

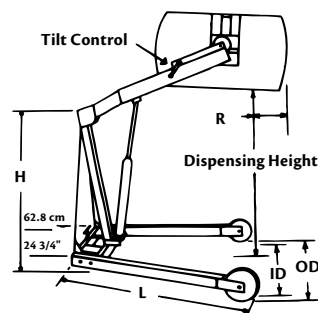
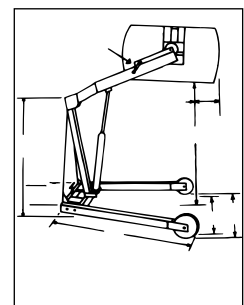

HOSE REELS

- Suitable for air and water
- Heavy-duty, reinforced steel stampings for increased strength
- Compact design allows reels to fit in tight locations
- Multi-position guide arms for multiple mounting options
- Kinkless, oil resistant high quality hose
- Spring rewind features long life spring with declutching arbour
- Durable, corrosion-resistant powder coat paint finish

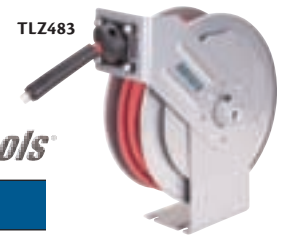

aurora tools

Model No.	Drive Type	Hose I.D.	Hose Length'	Max PSI	Hose Outlet (M) NPT"	Reel Inlet (F) NPT"	Dimensions				Wt. lbs.	
							W"	x	D"	x	H"	
TLZ482	Spring	1/4	35	300	1/4	3/8	6	x	15 1/2	x	14	26.6
TLZ483	Spring	3/8	25	300	1/4	3/8	6	x	15 1/8	x	13 7/8	26.2
TLZ484	Spring	3/8	35	300	1/4	3/8	6 5/8	x	17 1/2	x	16 1/2	34.7
TLZ485	Spring	3/8	50	300	1/4	3/8	6 1/2	x	20	x	18 3/8	40.3
TLZ486	Spring	1/2	50	300	1/2	1/2	6 5/8	x	20 1/4	x	17 7/8	44.3

WELDING HOSE REELS

- Heavy-duty, reinforced steel stampings for increased strength
- 1/4" oxygen and acetylene twin hose
- Leakproof double O-ring seals
- Compact design allows reels to fit in tight locations
- Multi-position guide arms for multiple mounting options
- Kinkless, oil resistant high quality hose
- Spring rewind features long life spring with declutching arbour
- Grade R hose
- Durable, corrosion-resistant powder coat paint finish

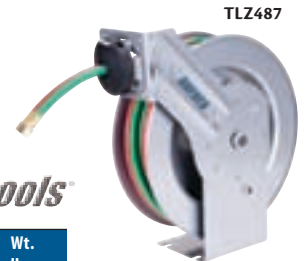

aurora tools

Model No.	Drive Type	Hose I.D."	Hose Length'	Max PSI	Oxygen Inlet & Outlet	Acetylene Inlet & Outlet	Dimensions				Wt. lbs.	
							W"	x	D"	x	H"	
TLZ487	Spring	1/4	25	300	9/16" x 18 UNF (Female)	9/16" x 18 UNF (Female)	8	x	14 3/4	x	13 5/8	25.9
TLZ488	Spring	1/4	50	300	9/16" x 18 UNF (Female)	9/16" x 18 UNF (Female)	8 5/8	x	20 1/2	x	20 1/2	42.2

AIR/WATER DELIVERY REELS

- Lightweight and easy to handle
- Made of corrosion proof polypropylene
- Working temperature: up to 65°C
- Designed to protect the hose and allow for easy cleaning of both hose and reel
- Wall or floor mount (Floor stand not included)
- Hose included

REELCRAFT



Model No.	Mfg. No.	Hose I.D."	Hose Length'	Max PSI	Hose Outlet (M) NPT"	Reel Inlet (F) NPT"	Dimensions"				Wt lbs.	
							W"	x	D"	x	H"	
FH821	SGA36500LP	3/8	50	232	3/8	3/8	9 1/2	x	22 3/4	x	19	23
FH822	SGA36650LP	3/8	66	232	3/8	3/8	9 1/2	x	22 3/4	x	19	27
FH823	SGA38500LP	1/2	50	232	1/2	1/2	9 1/2	x	22 3/4	x	19	27

HOSE REELS

- Heavy-duty, reinforced steel stampings for increased strength
- Permanently lubricated for long, trouble-free service
- Multi-position guide arms for versatile mounting options
- Kinkless, high quality hoses
- Spring rewind features long life spring with declutching arbour
- Durable, corrosion-resistant powder coat paint finish

REELCRAFT



INDUSTRIAL STEEL REELS

Model No.	Mfg. No.	Drive Type	Hose I.D."	Hose Length'	Max PSI	Hose Outlet" (M) NPT	Reel Inlet" (F) NPT	Reel Outlet" NPT	Dimensions			Wt. lbs.		
									W"	x	D"	x	H"	

AIR OR WATER REELS FOR MANUFACTURING PLANTS, BODY SHOPS, WORKSHOPS, SERVICE STATIONS, FABRICATORS, SPRAY BOOTHS - SOLD WITH HOSE

TN315	4435-OLP	Spring	1/4	35	300	1/4	3/8	-	5 3/8	x	12 5/8	x	12 7/8	20
TN317	4625-OLP	Spring	3/8	25	300	1/4	3/8	-	5 3/8	x	12 5/8	x	12 7/8	22
TN316	5635-OLP	Spring	3/8	35	300	1/4	3/8	-	6	x	13 1/2	x	14 1/2	25
TN318	7650-OLP	Spring	3/8	50	300	1/4	1/2	-	5 3/4	x	19	x	20 1/4	47
TN319	7850-OLP	Spring	1/2	50	300	3/8	1/2	-	5 3/4	x	19	x	20 1/4	51
FI058	5450-OLP	Spring	1/4	50	300	1/4	3/8	-	6	x	13 1/2	x	14 1/2	26
FH533	5650-OLP	Spring	3/8	50	300	1/4	3/8	-	6	x	16 1/2	x	17 1/2	36
FH534	81100-OLP	Spring	3/8	100	300	3/8	1/2	-	10 1/2	x	24	x	25 3/8	112
FH490	82100-OLP	Spring	1/2	100	300	1/2	1/2	-	10 1/2	x	24	x	25 3/8	121
FH491	83050-OLP	Spring	3/4	50	250	3/4	3/4	-	10 1/2	x	24	x	25 3/8	108
FH492	D83075-OLP	Spring	3/4	75	250	3/4	3/4	-	14 1/4	x	24	x	25 3/8	132
FH493	D84050-OLP	Spring	1	50	250	3/4	1	-	15 1/4	x	24	x	25 3/8	130
FH494	E9350-OLP	Spring	3/4	50	250	3/4	3/4	-	15 3/4	x	26 1/4	x	26 1/4	160
FH495	E9450-OLP	Spring	1	50	250	3/4	1	-	15 3/4	x	26 1/4	x	26 1/4	177

HAND CRANK FOR AIR OR WATER - DESIGNED FOR MEDIUM-DUTY APPLICATIONS REQUIRING LONGER LENGTHS OF HOSE - SOLD WITHOUT HOSE

FH506	CA32106L	Manual	1/2	100	1000	-	1/2	1/2 (F)	19	x	17 3/4	x	20 1/4	38
FH507	CA32112L	Manual	1/2	200	1000	-	1/2	1/2 (F)	25	x	17 3/4	x	20 1/4	46
FH508	CA33112L	Manual	3/4	100	1000	-	3/4	3/4 (F)	19	x	17 3/4	x	20 1/4	46
FI060	CA37118L	Manual	1	100	300	-	1	1 (M)	34	x	17 3/4	x	20 1/4	58

HOISTS & TROLLEYS

CHAIN HOISTS

- Lightweight steel construction
- Triple spur geared for easy lifting
- Load brake assures safety and load control
- High tensile alloy steel load chain for increased strength and durability
- Latched swivel hooks for added security
- Enclosed chain guide ensures dirt and dust do not affect operation

10' Lift Model No.	20' Lift Model No.	Capacity Tons	Capacity lbs.	Net Weight lbs.	Net Weight kg	No. of Chain Falls	Load Chain Dia. in.	Load Chain Dia. mm	Headroom in.	Headroom mm
LS534	LS540	1/2	1000	22	10	1	1/4	6	10 1/2	270
LS535	LS541	1	2000	26.4	12	1	1/4	6	12 1/2	317
LS536	LS542	1 1/2	3000	40.7	18 1/2	1	5/16	8	15 3/4	399
LS537	LS543	2	4000	44	20	1	5/16	8	16 1/4	414
LS538	LS544	3	6000	63.8	29	2	5/16	8	18 1/4	465
LS539	LS545	5	10000	100	45 1/2	2	7/16	10	25	636

10' Lift Model No.	20' Lift Model No.	A in.	A mm	B in.	B mm	C in.	C mm	D in.	D mm	K in.	K mm
LS534	LS540	5 1/4	131	5	127	10 1/2	270	1 3/8	36	1 3/16	30
LS535	LS541	5 1/2	140	6 1/4	158	12 1/2	317	1 5/8	40	1 1/4	34
LS536	LS542	6 1/4	161	7 1/4	187	15 3/4	399	1 3/4	45	1 1/2	38
LS537	LS543	6 1/4	161	7 1/4	187	16 1/4	414	2	50	1 5/8	41
LS538	LS544	6 1/4	161	8 1/4	210	18 1/4	465	2 1/4	58	1 7/8	48
LS539	LS545	7 1/4	186	10	253	25	636	2 1/2	64	2	52

Note: Dimensions are approximate and should be confirmed if important to your application

LEVER HOISTS

- Lightweight steel construction
- Short steel handle rotates 360° to allow operation in any position
- Load brake assures safety and load control
- High tensile alloy steel load chain for increased strength and durability
- Latched swivel hooks for added security
- Enclosed chain guide ensures dirt and dust do not affect operation

5' Lift Model No.	Capacity tons	Capacity lbs.	Net Weight lbs.	Net Weight kg	No. of Chain Falls	Load Chain Dia. in.	Load Chain Dia. mm
LS546	3/4	1500	15.5	7	1	1/4	6
LS547	1	2000	17.6	8	1	1/4	6
LS548	1 1/2	3000	24	11	1	5/16	8
LS549	3	6000	46	21	1	7/16	10
LS550	6	12000	68	31	2	7/16	10

5' Lift Model No.	A in.	A mm	B in.	B mm	C in.	C mm	D in.	D mm	H in.	H mm	L in.	L mm	K in.	K mm
LS546	5 3/4	148	3 1/2	90	5 1/4	136	1 1/2	40	12 3/4	325	11	280	1 5/16	34
LS547	5 3/4	148	3 1/2	90	5 1/4	136	1 1/2	40	12 3/4	325	11	280	1 5/16	34
LS548	6 3/4	172	3 3/4	98	6 1/4	160	1 3/4	45	15	380	16	410	1 7/16	38
LS549	7 3/4	200	4 1/2	115	7	180	2 1/4	58	18 3/4	480	16	410	1 7/8	48
LS550	7 3/4	200	4 1/2	115	9 1/4	235	2 1/2	64	24 1/2	620	16	410	2 1/16	52

Note: Dimensions are approximate and should be confirmed if important to your application

ADJUSTABLE TROLLEYS

- Easily adjusts to fit various flange and I-beams
- Use on straight or curved track
- Can be installed or removed at any position on the beam
- Heavy-duty cast iron wheels
- Deep width flange provides superior contact with the beam
- Geared trolleys include two geared wheels operated by hand chain
- Safety plate included

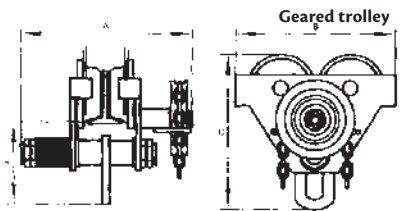
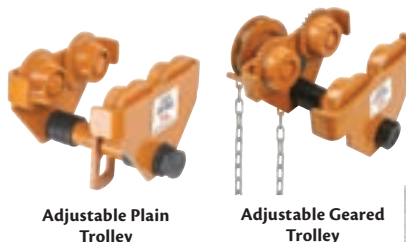

Model No.	Capacity tons	Capacity lbs.	I-Beam Flange Width in.	I-Beam Flange Width mm	Min. Curve Radius in.	Min. Curve Radius mm	Net Weight lbs.	Net Weight kg	A in.	A mm	B in.	B mm	C in.	C mm	H in.	H mm
-----------	---------------	---------------	-------------------------	------------------------	-----------------------	----------------------	-----------------	---------------	-------	------	-------	------	-------	------	-------	------

PLAIN TROLLEYS

LS551	1/2	1000	2 1/2 - 5 1/2	64 - 140	35	900	15.4	7	9	230	8 1/4	212	7 3/4	198.5	4 1/2	113
LS552	1	2000	2 1/2 - 5 1/2	64 - 140	39	1000	26.4	12	10	254	10	255	9 1/8	231.5	5	128
LS553	2	4000	3 - 6 1/2	76 - 165	47	1200	48.4	22	11 1/5	294	11 7/8	302	11	278	6	152
LS554	3	6000	3 - 8	76 - 203	55	1400	66	30	13 1/2	344	13 1/2	344	13 1/4	338	7 3/8	186
LS555	5	10000	3 1/2 - 8	88 - 203	78	2000	121	55	14 1/4	360	14 7/8	378	15 1/2	393	8 5/8	219

GEARED TROLLEYS

LS556	1/2	1000	2 1/2 - 5 1/2	64 - 140	35	900	30.8	14	12 1/8	308.5	8 1/4	212	7 3/4	198.5	4 1/2	113
LS557	1	2000	2 1/2 - 5 1/2	64 - 140	39	1000	41.8	19	13	328.5	10	255	9 1/8	231.5	5	128
LS558	2	4000	3 - 6 1/2	76 - 165	47	1200	63.8	29	14 1/4	361.5	11 7/8	302	11	278	6	152
LS559	3	6000	3 - 8	76 - 203	55	1400	88	40	16 7/8	428.5	13 1/2	344	13 1/4	338	7 3/8	186
LS560	5	10000	3 1/2 - 8	88 - 203	78	2000	143	65	17 1/8	434	14 7/8	378	15 1/2	393	8 5/8	219

Note: Dimensions are approximate and should be confirmed if important to your application

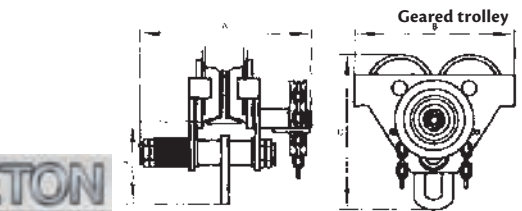
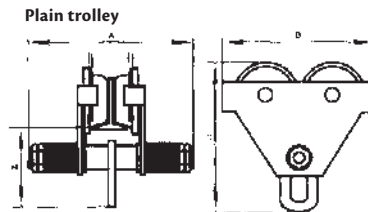
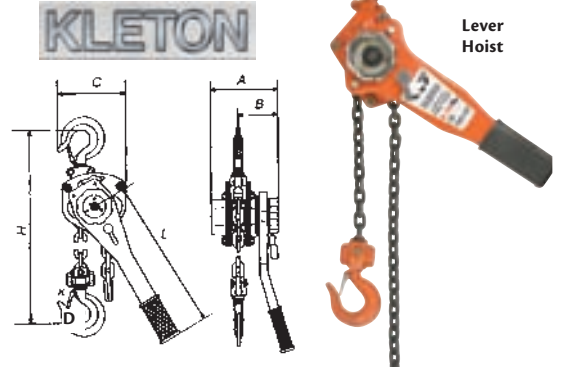
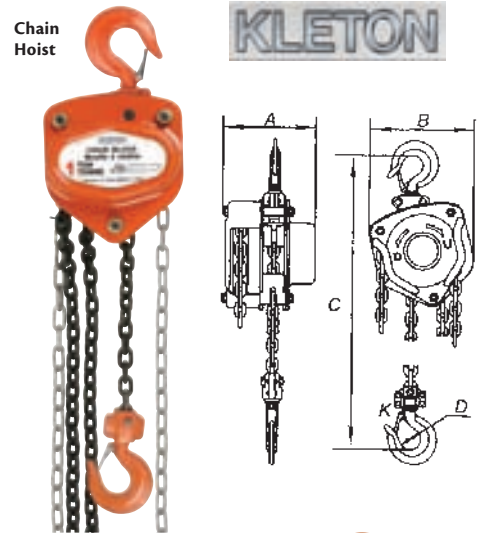

CHAIN & NYLON LIFT SLINGS

CHAIN SLINGS

- Quality grade 80 alloy steel assembled, feature a design factor of 4:1
- Proof tested and certified to twice the working load limit
- Proof test certificate issued with each sling
- Available with sling hook or grab hook
- Three and four leg assemblies are available upon request
- Slings come with identification tag indicating size, description and working load limit

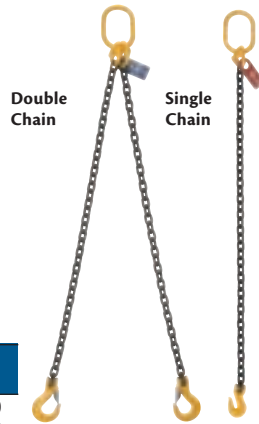
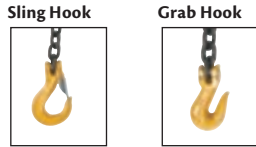

CAPACITY LBS.

Chain size"	Single	60°	Double 45°	30°
9/32	3500	6100	4900	3500
3/8	7100	12300	10000	7100
1/2	12000	20800	17000	12000
5/8	18100	31300	25600	18100

Chain Size"	Hook Type	5' Sling Model No.	8' Sling Model No.	10' Sling Model No.
SINGLE CHAIN				
9/32	Sling	LS486	LS494	LS502
	Grab	LS487	LS495	LS503
3/8	Sling	LS488	LS496	LS504
	Grab	LS489	LS497	LS505
1/2	Sling	LS490	LS498	LS506
	Grab	LS491	LS499	LS507
5/8	Sling	LS492	LS500	LS508
	Grab	LS493	LS501	LS509
DOUBLE CHAIN				
9/32	Sling	LS510	LS518	LS526
	Grab	LS511	LS519	LS527
3/8	Sling	LS512	LS520	LS528
	Grab	LS513	LS521	LS529
1/2	Sling	LS514	LS522	LS530
	Grab	LS515	LS523	LS531
5/8	Sling	LS516	LS524	LS532
	Grab	LS517	LS525	LS533

Available in other lengths

NYLON SLINGS

All Uni-Web nylon slings are rated with a 5:1 design factor. Used in conjunction with overhead cranes, hoists or winches. Nylon slings are available in single or double ply to protect heavy, irregular sized loads from scratching or marring. Slings must be checked frequently. Should any surface area show signs of wear or cutting, the sling must be replaced immediately. Each is tagged with manufactured date and capacity.

TYPE 1 CHOKER SLINGS

- Forged alloy end fittings - triangle at one end, choker at the other
- Webbing forms a slip noose by slipping the triangle through the choker

TYPE 2 TRIANGLE SLINGS

- Forged alloy end fittings for single or double sling basket hitches
- Soft webbing conforms to the load shape without damaging painted or polished surfaces

TYPE 3 DOUBLE EYE SLINGS

- Commonly used as a basket and/or choker hitch
- For choker hitch pass one eye through the other flat eye, also makes for easy withdrawal from beneath loads

TYPE 4 TWISTED EYE SLINGS

- Twisted eyes make full functional contact with lifting hooks without the use of hardware
- Widely used for both choker and basket hitches

TYPE 5 ENDLESS SLINGS

- Most versatile and widely used sling
- The economical answer to most lifting problems
- Ideal for vertical, choker, and basket hitches

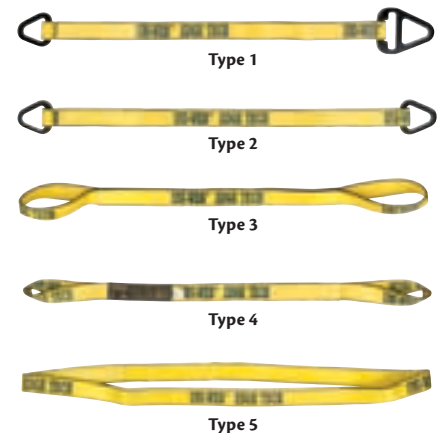

LOAD LIMIT FOR TYPE 1-2-3-4 CAPACITY LBS.

Width"	Vertical		Choker		Basket	
	Single	Double	Single	Double	Single	Double
1	1600	3200	1280	2560	3200	6400
2	3200	6200	2560	4960	6400	12400
3	4700	8800	3840	7000	9400	17600
4	6200	11000	4960	8800	12400	22000

Width"	Ply	3'	4'	6'	8'	10'	12'		
		Model No.	Model No.	Model No.	Model No.	Model No.	Model No.		
TYPE 1	2	Single	LS270	LS276	LS282	LS288	LS294	LS300	
		Double	LS271	LS277	LS283	LS289	LS295	LS301	
	3	Single	LS272	LS278	LS284	LS290	LS296	LS302	
		Double	LS273	LS279	LS285	LS291	LS297	LS303	
	4	Single	LS274	LS280	LS286	LS292	LS298	LS304	
		Double	LS275	LS281	LS287	LS293	LS299	LS305	
	TYPE 2	2	Single	LS306	LS312	LS318	LS324	LS330	LS336
			Double	LS307	LS313	LS319	LS325	LS331	LS337
3		Single	LS308	LS314	LS320	LS326	LS332	LS338	
		Double	LS309	LS315	LS321	LS327	LS333	LS339	
4		Single	LS310	LS316	LS322	LS328	LS334	LS340	
		Double	LS311	LS317	LS323	LS329	LS335	LS341	
TYPE 3		1	Single	LS342	LS350	LS358	LS366	LS374	LS382
			Double	LS343	LS351	LS359	LS367	LS375	LS383
	2	Single	LS344	LS352	LS360	LS368	LS376	LS384	
		Double	LS345	LS353	LS361	LS369	LS377	LS385	
	3	Single	LS346	LS354	LS362	LS370	LS378	LS386	
		Double	LS347	LS355	LS363	LS371	LS379	LS387	
	4	Single	LS348	LS356	LS364	LS372	LS380	LS388	
		Double	LS349	LS357	LS365	LS373	LS381	LS389	

LOAD LIMIT FOR TYPE 5 CAPACITY LBS.

Width"	Vertical		Choker		Basket	
	Single	Double	Single	Double	Single	Double
1	3200	6200	2560	4960	6400	12400
2	6200	12400	4960	9930	12400	24800
3	9400	17600	7520	14080	18800	35200
4	12400	22000	9920	17600	24800	44000

Width"	Ply	3'	4'	6'	8'	10'	12'	
		Model No.	Model No.	Model No.	Model No.	Model No.	Model No.	
TYPE 4	1	Single	LS390	LS398	LS406	LS414	LS422	LS430
		Double	LS391	LS399	LS407	LS415	LS423	LS431
	2	Single	LS392	LS400	LS408	LS416	LS424	LS432
		Double	LS393	LS401	LS409	LS417	LS425	LS433
	3	Single	LS394	LS402	LS410	LS418	LS426	LS434
		Double	LS395	LS403	LS411	LS419	LS427	LS435
	4	Single	LS396	LS404	LS412	LS420	LS428	LS436
		Double	LS397	LS405	LS413	LS421	LS429	LS437
TYPE 5	1	Single	LS438	LS446	LS454	LS462	LS470	LS478
		Double	LS439	LS447	LS455	LS463	LS471	LS479
	2	Single	LS440	LS448	LS456	LS464	LS472	LS480
		Double	LS441	LS449	LS457	LS465	LS473	LS481
	3	Single	LS442	LS450	LS458	LS466	LS474	LS482
		Double	LS443	LS451	LS459	LS467	LS475	LS483
	4	Single	LS444	LS452	LS460	LS468	LS476	LS484
		Double	LS445	LS453	LS461	LS469	LS477	LS485

Available in other lengths

VACUUM CUPS & CLAMPS

VACU-LIFTERS

- Powerfully grips and holds material safely
- Vacuum created by cups for easy lifting of heavy weights by either one or two cups
- Ideal for moving heavy gauge metal, marble slabs, plate glass and plastic sheet
- Extended Vacu-Lifters keep operators hands away from dangerous areas
- Especially used in punch press applications
- Made of strengthened steel rods and oil resistant rubber cups
- Positive push-button release valve assures instant release
- 4:1 safety factor

Model No.	Cup Dia."	Cap. lbs.	Release Type	Handle Length"
A. HEAVY-DUTY SINGLE CUP				
LA881	3	15	Trigger-Pull	-
LA613	4	25	Trigger-Pull	-
LA615	5	35	Trigger-Pull	-
B. HEAVY-DUTY DOUBLE CUP				
LA882	3	30	Pull-Bar	7
LA640	4	50	Pull-Bar	10
LA641	5	75	Pull-Bar	10
C. TWO-MAN VACUUM LIFTER - DOUBLE CUP				
LA619	4	50	Pull-Ring	31
LA620	5	75	Pull-Ring	31



Model No.	Cup Dia."	Cap. lbs.	Release Type	Handle Length"
D. FINGER GRABBER				
LA612	2 1/4	4	Tab	-
LA883	2 1/4	6	-	-
E. 2-FINGER GRABBER				
LA621	3 1/4	10	Tab	-
F. GRIFTER				
LA645	3 1/4	15	Lip Edge	-
G. MEDIUM-DUTY VACU-LIFT				
LA616	3 1/4	10	Push-Button	-



MANUALLY OPERATED TRIPLE HANDCUPS

- Designed to handle smooth, non-porous loads such as metal, glass, plastic etc. more effectively and more efficiently
- Cast aluminum body with three individual cups
- Ideal for large-sized sheets of material
- 4 3/4" cup diameter
- Capacity: 110 lbs.

Model No. LA863



BEAM CLAMPS

- Beam clamps lift, transfer and position beams from 3" to 10" flange widths using rapid adjustment screw spindle
- Used as portable quick attachments for hoisting and rigging equipment
- 3" diameter eye has cross loading capacity of 15° off centre
- 2:1 safety factor

Model No.	Cap. Tons*	Jaw Opening"	Wt. lbs.
LA178	2	3 - 7 1/2	13
LA179	3	3 - 7 1/2	15
LA180	4	6 - 10	19

* (SWL) Safe Working Loads



GX LIFTING CLAMPS

- Entirely drop forged and heat treated
- Strong, yet lightweight compared to other clamps
- Ideal for both vertical and horizontal-to-vertical lifting
- Features a patented wear out indicator system
- 100% proof tested to twice the working load limit

Campbell®

Model No	Capacity Tons	Grip Range"	Wt. lbs.
LB606	1/2	1/16 - 5/8	4
LB607	1	1/16 - 3/4	8
LB608	3	1/16 - 1	17



MANUALLY OPERATED HAND VACUUM CUPS

- Designed to handle smooth, non-porous loads such as metal, glass, plastic etc. more effectively and more efficiently

PUMP ACTION HANDCUPS

- Cast aluminum body with built-in hand pump, 8 1/4" cup diameter
- Comes with carrying case (one cup per case)
- Capacity: 123 lbs.

Model No. LA858



LA858

DOUBLE HANDCUPS

- Model No. LA859 Cast aluminum body
 - 4 7/8" cup diameter
 - Capacity: 66 lbs.
- Model No. LA860 Plastic body
 - 4 5/8" cup diameter
 - Capacity: 66 lbs.



LA859

GRADE 30 WELDED CHAINS

General purpose chain used for binding, towing, and logging applications.

Important: The chains listed below are not to be used for overhead lifting.

Suitable for ordinary purposes such as log chains, guard rail chains and towing chains. To be used for certain implement and equipment parts where high strength to weight ratios are not a consideration. Coil chain is made with Blu-Krome.



Campbell®

Model No.	Dim."	Description	Working load Limit lbs.	Feet /Pkg.
LB332	3/16	Proof Coil Chain	800	250
LB333	1/4	Proof Coil Chain	1300	141
LB334	5/16	Proof Coil Chain	1900	92
LB335	3/8	Proof Coil Chain	2650	63
LB336	1/2	Proof Coil Chain	4500	40

HAND WINCHES

AUTOMATIC BRAKE WINCHES

- Zinc plated
- Self-activating automatic brake system
- Positive holding action of brake system while raising and lowering loads
- Comfort grip handle for positive hold
- Double disc brake on **LA692** and **LA693**
- **Load-Lok** automatic disc brake system on **LB257** and **LA691**
- Cable pays out after load has been lowered, continued cranking on the winch allows cable remaining on drum to feed out automatically

WORM GEAR WINCHES

- Self-activated brake mechanism holds load safely in place
- Double mesh worm gear train for quiet operation/optimum wear
- Rear frame reinforcing bar
- Large diameter drum hubs protect steel cable from damage
- High carbon steel on drum gears last longer
- Large handle grip for easy cranking
- **LA695** includes drive ring and 10" handle

Model No.	Type	Cap. lbs.	Gear Ratio	Hub Dia."	Reel'	Max. Cable Dia."	Handle Length'	Wt. lbs.
LB257	Automatic Brake Winch	600	1:1	1 1/4	85	1/8	11	7.5
LA691	Automatic Brake Winch	1000	4.1:1	2 1/4	60	7/32	11	8
LA692	Automatic Brake Winch	1500	5.1:1	2 1/2	88	1/4	11	15
LA693	Automatic Brake Winch	2500	15.8:1	3 1/8	75	5/16	11	24
LA694	Worm Gear Winch	2000	4.1:1	1 1/2	100	3/16	8	11
LA695	Worm Gear Winch	3000	5.1:1	3 1/8	90	1/4	10	31

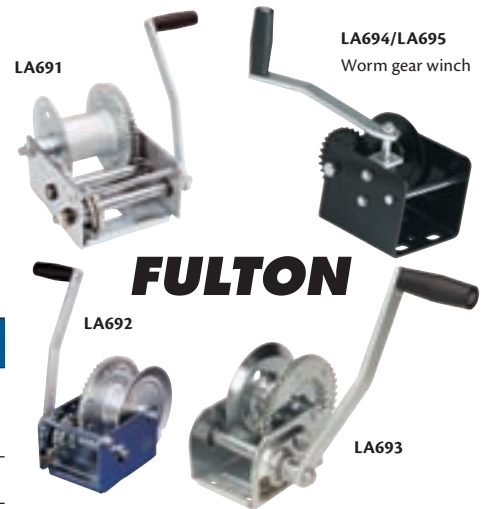

ALLOY STEEL HOOKS

- Constructed of grade 100 alloy steel
- Recommended for overhead lifting

Clevis Sling Hooks with Latch

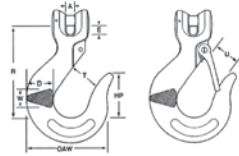

Clevis Grab Hooks

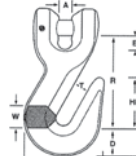

Connecting links

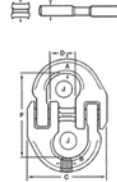

CHAIN HOOKS

- All hooks are grade 40 with a self-coloured finish
- Not to be used for overhead lifting



CLEVIS SLING HOOKS WITH LATCH – GRADE 80

Model No.	Recom. Chain"	Dia. mm	Max. Working Load lbs.	R mm	T mm	U mm	A mm	E mm	D mm	W mm	HP mm	OAW mm	Wt. lbs.
LB402	9/32	7	4300	95	32	27	8	9	29	19	44	98	1.3
LB404	1/2	13	15 000	146	48	40	14	16	48	32	68	156	5.4

CLEVIS GRAB HOOKS – GRADE 80

Model No.	Recom. Chain"	Dia. mm	Max. Working Load lbs.	Load Pin										Wt. lbs.
				R mm	T mm	A mm	E mm	Dia. mm	D mm	W mm	HP mm	OAW mm		
LB407	9/32	7	4300	60	10	8	9	10	21	16	32	51	0.5	
LB408	3/8	10	8800	74	13	11	13	13	32	19	41	71	1.6	
LB409	1/2	13	15 000	94	17	14	16	16	38	24	51	89	2.6	
LB410	5/8	16	22 600	113	20	18	19	19	44	31	67	105	5.8	
LB411	3/4	20	35 300	130	25	21	22	22	54	35	83	124	8.8	

CHAIN TO COMPONENT CONNECTING LINKS

Model No.	Recom. Chain"	Dia. mm	Max. Working Load lbs.	Load kg	A mm	B mm	C mm	D mm	E mm	F mm	G mm	Wt. lbs.
LB418	7/32	5.5	2100	970	7	6	33	11	4	39	10	0.1
LB419	9/32	7	4300	1950	10	9	44	14	5	45	10	0.27
LB420	3/8	10	8800	4000	13	11	60	21	8	62	9	0.55
LB421	1/2	13	15 000	6800	17	14	76	26	10	86	12	2
LB422	5/8	16	22 600	10 300	21	18	98	33	12	99	14	3
LB423	3/4	19	35 300	16 000	24	24	117	40	14	121	16	4
LB424	1	26	47 700	21 600	31	29	149	52	17	149	35	8
LB425	1 1/4	32	72 300	32 800	38	35	187	58	24	179	41	16

JIB BOOMS

- Converts fork lift trucks into mobile jib cranes for infinite variety of uses
- Fully adjustable booms reach out, pick-up, and move heavy long loads making fork lift more versatile
- Boom slips onto the forks and anchors to the truck with a safety chain
- Includes two adjustable hooks

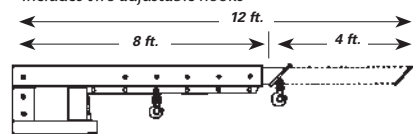

Model No.	Boom Type	Fork Lift Cap. lbs.	Boom Cap. lbs. (Reach ft.)							Wt. lbs.
			0-7	8	9	10	11	12	5"	
LA188	Fixed	3000	1000	800	725	650	600	500	10	255
LA187	Elevating	3000							10	285
LA186	Fixed	8000	3000	2700	2400	2200	2000	1900	12	438
LA185	Elevating	8000							12	483

F.O.B. Vaudreuil, Quebec. Items are made to order and are non-returnable.

Model No.	Dia."	Max. Working Load Limit lbs.
HEAT TREATED CLEVIS GRAB HOOK		
LT357	1/4	2600
LT273	5/16	3900
LT274	3/8	5400
LT358	1/2	9200
HEAT TREATED SLIP HOOK		
LT275	1/4	2600
LT276	5/16	3900
LT359	3/8	5400
LT360	1/2	9200

LIFTING HOOKS

Highly secure industrial lifting hooks are manufactured of grade 100 alloy steel, which can be used in all applications. When used in conjunction with grade 80 or 100 alloy chain and fittings, assemblies may be used for overhead lifting.



Model No.	Dia."	Max. Working Load Limit lbs.
LT277	9/32	4300
LT278	3/8	8800
LT279	1/2	15 000
LT280	5/8	22 600
LT281	3/4	35 300

CRANES

F.O.B. Vaudreuil, Quebec. Items are made to order and are non-returnable.

PORTABLE FLOOR CRANES

- Lifts, lowers, positions and moves with ease
- Hand operated hydraulic pump lifts fully extended boom over 8'
- Crane moves easily with smooth rolling casters
- Fully collapsible, knocks down in seconds for easy storage
- 30" adjustable chain and hook supplied
- Shipped knocked down

Folded for Storage



MuscleMate

Model No.	Cap. lbs.	Overall Height"	Overall Length"	Overall Width"	Caster Type	Wt. lbs.
LA572	1000	69 1/4	63 1/2	31	Phenolic	260
LA567	2000	69 1/4	63 1/2	37	Cast Iron	275

BOOM CAPACITY

Model No.	Boom Reach"/Capacity lbs.			
	1 st position	2 nd position	3 rd position	4 th position
LA572	56 1/2/1000	63 1/2/770	70 1/2/320	N/A
LA567	52 1/2/2000	62 1/2/1280	72 1/2/520	82 1/2/380

REPLACEMENT PUMP

LA838 Replacement Hydraulic Pump

FLOOR CRANES

REVERSE BOOM

- Counter weight design allows crane to be close to item being lifted without obstruction by the legs
- Reaches over machinery or loading docks easily
- Useful for supplying materials to production areas not serviced by overhead cranes
- Roller bearing wheels, swivel wheel foot brakes, manual pump, adjustable chain and hook, safety pins, push handle and counterweight all included
- LA793 and LA794 fold up for compact storage and transportation

MuscleMate

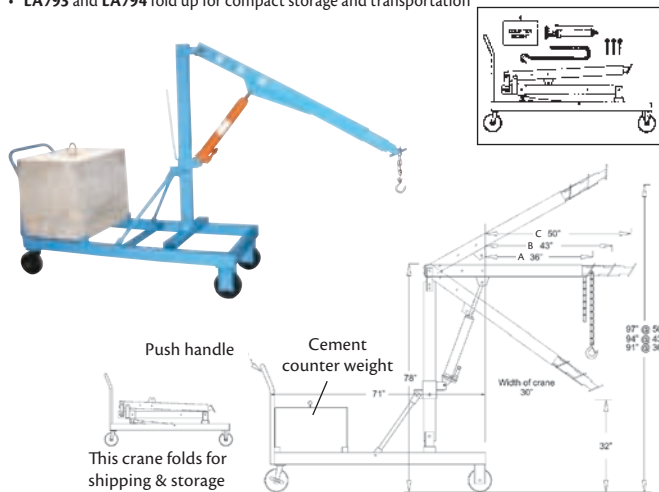

Model No.	Boom Capacity lbs.			Counterweight lbs.	Width"	Wt. lbs.
	A	B	C			
LA793*	1000	770	650	650	30	1050
LA794*	2000	1280	1000	1300	30	1750
LA795	3000	2000	1500	1950	30	2450

REPLACEMENT PUMPS

LA838 Replacement Hydraulic Pump for LA793 and LA794
LA840 Replacement Hydraulic Pump for LA795

DIMENSIONS

A"	Boom Reach			Lift Clearance	
	B"	C"	Min"	Max"	
36	43	50	32	91 @ 36, 94 @ 43, 97 @ 50	

* Shipped knocked down

PORTABLE SHOP CRANES

- Versatile crane provides lifting power to any job site
- Fast and easy assembly/disassembly
- Disassembled unit fits into trunk of car
- Heaviest piece weighs 40 lbs.
- Crane is equipped with heavy-duty cast iron wheels, manual pump, safety hook and push handle
- Shipped knocked down

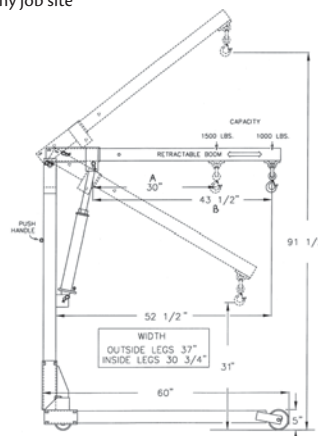
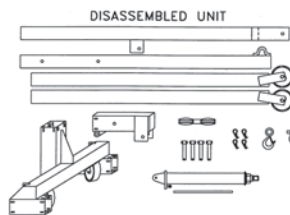

MuscleMate

Model No.	Boom Reach"/Capacity lbs.		Lift Clearance		Width Inside Legs"	Wt. lbs.
	A	B	Min"	Max"		
LA791	30/1500	43 1/2/1000	31	91 1/2	30 3/4	230

REPLACEMENT PUMP

LA838 Replacement Hydraulic Pump

ROTATING

- Move load to either side quickly and safely
- Adjustable outrigger provides stability for side loading
- Allows boom to swing 200° to either side while holding a full load
- Useful in tight work spaces
- Outrigger extends to one side at a time
- Equipped with heavy-duty roller bearing wheels, manual pump, adjustable chain and hook, safety pins and guide handle

MuscleMate

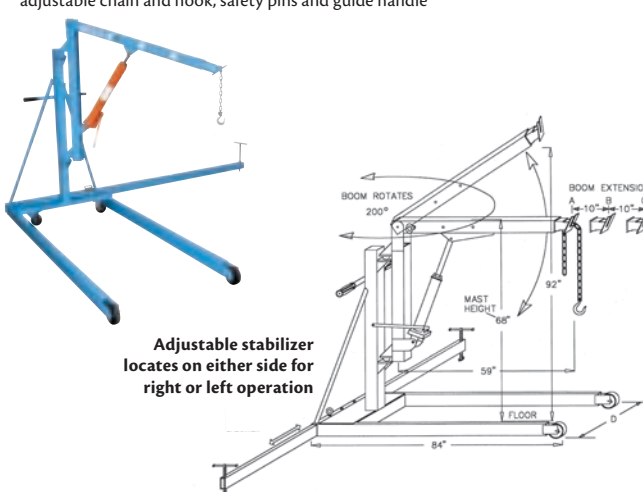

Model No.	Boom Capacity lbs.			Width" D	Wheel Dia."		Wt. lbs.
	A	B	C		Front	Rear	
LA796	1000	770	320	36	5	4	450
LA797	2000	1280	520	36	5	4	550
LA798	3000	1500	800	40	8	6	690

REPLACEMENT PUMPS

LA838 Replacement Hydraulic Pump for LA796 and LA797
LA840 Replacement Hydraulic Pump for LA798

DIMENSIONS

A"	Boom Reach			Lift Clearance	
	B"	C"	Min"	Max"	
59	69	79	68	92	

CRANES & PALLET LIFTERS

F.O.B. Vaudreuil, Quebec. Items are made to order and are non-returnable.

ADJUSTABLE GANTRY CRANES

- Adjustable height between 8' and 14'
- Four heavy-duty swivel casters with wheel brakes
- Beam type is I and taper-wheel trolleys are required
- Hoist and trolley not included
- Unit can be adjusted with or without casters
- Shipped knocked down

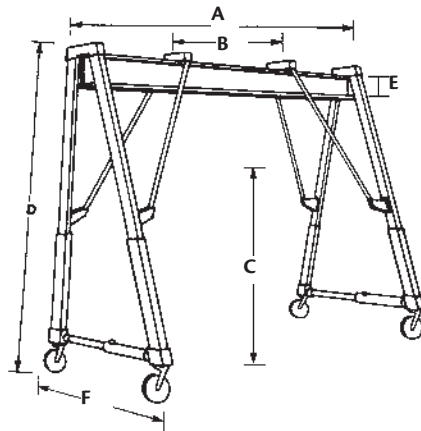

Model No.	Lifting Cap. lbs.	Overall Span A'	Clear Span B	Hook Lift Min/Max C	Overall Height Min/Max D	Beam Height E"	Wheel Spread Min/Max F	Beam Width"	Wt. lbs.
LA189	2000	10	4'7"	6'6 1/2"/12' 4 1/2"	8'9"/14'7"	6	4'7"/7'	3 3/8	885
LA190	2000	15	9'7"	6'4 1/2"/12'2 1/2"	8'9"/14'7"	8	4'7"/7'	5 1/4	1050
LA191	4000	10	4'7"	6'4 1/2"/12'2 1/2"	8'9"/14'7"	8	4'7"/7'	4	1165
LA192	4000	15	9'7"	5'10 1/2"/11'8 1/2"	8'9"/14'7"	10	4'7"/7'	5 3/4	1370
LA193	6000	10	4'7"	5'9"/11'7"	8'9"/14'9"	10	4'10"/7'3"	4 5/8	1430
LA194	6000	15	9'7"	5'9"/11'7"	8'9"/14'9"	10	4'10"/7'3"	5 3/4	1615

PALLET LIFTERS

- Ideal for use with a crane system or truck cranes
- Pallet lifters available in four capacities with three adjustable or non-adjustable fork lengths to choose from

A - Throat height (clear): 48"
 B - Fork length: 36", 42" or 48"
 C - Width (O.D.): 27"

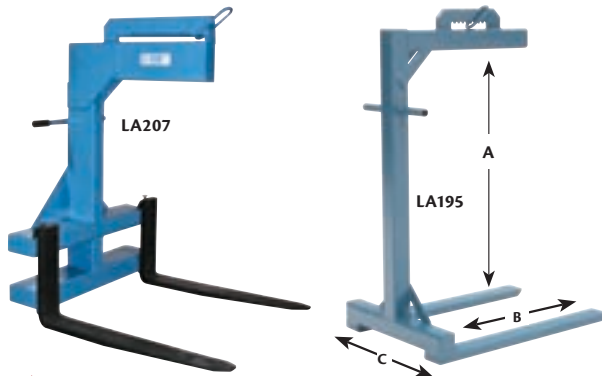

Standard Model No.	Wt. lbs.	Adjustable Model No.	Wt. lbs.	Cap lbs.	Fork Length"
LA195	190	LA207	270	1000	36
LA196	230	LA208	295		42
LA197	255	LA209	325		48
LA198	195	LA210	280	2000	36
LA199	233	LA211	305		42
LA200	260	LA212	335		48
LA201	310	LA213	380	4000	36
LA202	337	LA214	430		42
LA203	370	LA215	475		48
LA204	522	LA216	575	6000	36
LA205	662	LA217	560		42
LA206	602	LA218	612		48

ECONOMICAL ADJUSTABLE PALLET LIFTERS

- Ideal for use with crane systems or with truck cranes
- Pallet lifters are available in two capacities with three adjustable or non-adjustable fork lengths to choose from

A - Throat height (clear): 48"
 B - Fork length: 36", 42" or 48"
 C - Width (O.D.): 27"



Model No.	Cap. lbs.	Fork Length"	Wt. lbs.
LT475	1000	36	190
LT476	1000	42	230
LT477	1000	48	270
LT478	2000	36	195
LT479	2000	42	235
LT480	2000	48	260