

HI-STAK PLASTIC BINS

- Innovative stacking design allows for greater visibility and easier access to contents
- Guaranteed unbreakable and distortion-free from -40°C to 120°C
- Unaffected by oil, alkaline and most acids
- Ideal in production or for parts storage
- I.D. card with clear plastic shield provided with each bin



Connector clip allows for back-to-back mounting



1" riser legs increase loading capacity and stability



Inclined faceplate with removable label and protector

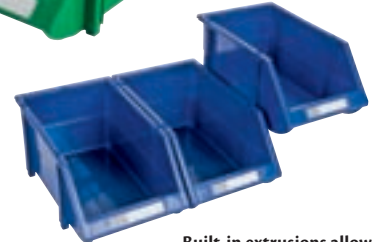

Built-in extrusions allow side-by-side interlock



Stackable using built-in feet

Model No.				Dimensions					Qty	Wt.
Blue	Yellow	Green	Red	W"	x	D"	x	H"	/Case	lbs.
CB260	CB261	CC234	CC242	4 13/16	x	7 1/8	x	3 3/16	60	0.10
CB262	CB263	CC235	CC243	5 7/8	x	9 13/16	x	4 11/16	36	0.15
CB264	CB265	CC236	CC244	8 3/16	x	14	x	6 3/16	18	0.35
CC239	CC240	CC237	CC245	7 7/8	x	17 11/16	x	7	12	0.55
CB266	CB267	CC238	CC246	11 13/16	x	17 11/16	x	7	8	0.60

Add 1 inch to overall height when stacking on legs

WIRE SHELVING UNITS WITH STORAGE BINS

Same great features as the *Kleton* chromate wire shelving, but with the added convenience of heavy-duty storage bins.

- Adjustable chromate wire shelves
- Wire shelving resists corrosion and provides greater visibility to stored parts
- Wire shelves prevent build up of dust and dirt
- Bins are unaffected by oil, alkaline, and most acids
- Ideal in production or for parts storage
- Stationary units total capacity should not exceed 2000 lbs.
- NSF Certified (wire shelving units only)
- Assembly required



RL815



RL820

Model No.	Shelving Dim. W" x D" x H"	No. of Shelves	Bin Dimensions					No. of Bins	Colour
			W"	x	D"	x	H"		
RL815	36 x 14 x 74	8	8 3/16	x	14	x	6 3/16	28	Blue
RL816	36 x 14 x 74	8	8 3/16	x	14	x	6 3/16	28	Yellow
RL817	36 x 14 x 74	8	8 3/16	x	14	x	6 3/16	28	Green
RL818	36 x 14 x 74	8	8 3/16	x	14	x	6 3/16	28	Red
RL819	36 x 18 x 74	8	7 7/8	x	17 11/16	x	7	28	Blue
RL820	36 x 18 x 74	8	7 7/8	x	17 11/16	x	7	28	Yellow
RL821	36 x 18 x 74	8	7 7/8	x	17 11/16	x	7	28	Green
RL822	36 x 18 x 74	8	7 7/8	x	17 11/16	x	7	28	Red
RL827	48 x 18 x 74	8	7 7/8	x	17 11/16	x	7	28	Blue
			11 13/16	x	17 11/16	x	7	7	Blue
RL828	48 x 18 x 74	8	7 7/8	x	17 11/16	x	7	28	Yellow
			11 13/16	x	17 11/16	x	7	7	Yellow
RL829	48 x 18 x 74	8	7 7/8	x	17 11/16	x	7	28	Green
			11 13/16	x	17 11/16	x	7	7	Green
RL830	48 x 18 x 74	8	7 7/8	x	17 11/16	x	7	28	Red
			11 13/16	x	17 11/16	x	7	7	Red
RL831	48 x 18 x 74	8	7 7/8	x	17 11/16	x	7	7	Blue
			11 13/16	x	17 11/16	x	7	21	Blue
RL832	48 x 18 x 74	8	7 7/8	x	17 11/16	x	7	7	Yellow
			11 13/16	x	17 11/16	x	7	21	Yellow
RL833	48 x 18 x 74	8	7 7/8	x	17 11/16	x	7	7	Green
			11 13/16	x	17 11/16	x	7	21	Green
RL834	48 x 18 x 74	8	7 7/8	x	17 11/16	x	7	7	Red
			11 13/16	x	17 11/16	x	7	21	Red
RL839	36 x 18 x 74	8	7 7/8	x	17 11/16	x	7	7	Blue
			11 13/16	x	17 11/16	x	7	14	Blue
RL840	36 x 18 x 74	8	7 7/8	x	17 11/16	x	7	7	Yellow
			11 13/16	x	17 11/16	x	7	14	Yellow
RL841	36 x 18 x 74	8	7 7/8	x	17 11/16	x	7	7	Green
			11 13/16	x	17 11/16	x	7	14	Green
RL842	36 x 18 x 74	8	7 7/8	x	17 11/16	x	7	7	Red
			11 13/16	x	17 11/16	x	7	14	Red

BINS

QUANTUM™ BINS

- Heavy-duty, virgin, high density polypropylene/polyethylene
- Autoclavable up to 250°F
- Large multiple label slots • Stackable
- Optional dividers and clear windows available for most units
- Hangs on louvered panels, rails and carts
- Jumbo bins cannot hang on louvered panels or rail systems
- Jumbo bins have a stack capacity of up to 100 lbs. and can stack up to six bins high
- Mobile bins come with four swivel 3" casters with brakes
- Made of FDA approved materials



Model No.						Mfg. No.	Outside Dimensions				Qty /Case	Bin load Cap. lbs.	
Black	Blue	Yellow	Red	Ivory	Green		W"	x	D"	x			H"
CC975	CB739	CB741	CB744	CB745	CC264	QUS 200	4 1/8	x	5	x	3	24	8
CC976	CB747	CB750	CB751	CB753	CC265	QUS 210	4 1/8	x	5 3/8	x	3	24	10
CC977	CB756	CB757	CB759	CB762	CC266	QUS 220	4 1/8	x	7 1/2	x	3	24	10
CF376	CF377	CF378	CF379	CF380	CF381	QUS 221	6	x	9 1/4	x	5	12	20
CD276	CD249	CD262	CD263	CD264	CD265	QUS 224	4 1/8	x	10 7/8	x	4	12	30
CC978	CB763	CB765	CB766	CB768	CC267	QUS 230	5 1/2	x	11	x	5	12	30
CC974	CC971	CC972	CC973	CC990	CC970	QUS 234	5 1/2	x	14 3/4	x	5	12	50
CC980	CB775	CB777	CB778	CB780	CC269	QUS 235	11	x	11	x	5	6	50
CC576	CB781	CB783	CB784	CB786	CC270	QUS 239	8 1/4	x	11	x	7	6	50
CC577	CB787	CB789	CB790	CB792	CC271	QUS 240	8 1/4	x	14 3/4	x	7	12	60
CF382	CF383	CF384	CF385	CF386	CF387	QUS 241	8 1/4	x	13 5/8	x	6	12	60
CF388	CF389	CF390	CF391	CF392	CF393	QUS 242	8 1/4	x	13 5/8	x	8	12	60
CC983	CC282	CC283	CC284	CC285	CC286	QUS 245	16 1/2	x	11	x	5	6	60
CC578	CB794	CB795	CB796	CB797	CC272	QUS 250	16 1/2	x	14 3/4	x	7	6	75
CC579	CB798	CB800	CB801	CB802	CC273	QUS 255	11	x	16	x	8	4	75
CC580	CB803	CB804	CB806	CB807	CC274	QUS 260	11	x	18	x	10	4	75
CC581	CC287	CC288	CC289	CC290	CC291	QUS 265	8 1/4	x	18	x	9	6	60
CC582	CB808	CB809	CB810	CB811	CC275	QUS 270	16 1/2	x	18	x	11	3	75
CD674*	CD669*	CD670*	CD671*	CD673*	CD672*	QUS 275MOB	16 1/2	x	18	x	14	3	-
JUMBO 24" DEEP ULTRA BINS (do not hang on louvered panels or rail systems)													
-	CD545	CD547	CD546	-	-	QUS950	8 1/4	x	23 7/8	x	7	6	-
-	CD548	CD550	CD549	-	-	QUS951	8 1/4	x	23 7/8	x	9	6	-
-	CD551	CD553	CD552	-	-	QUS952	11	x	23 7/8	x	7	4	-
-	CD554	CD556	CD555	-	-	QUS953	11	x	23 7/8	x	10	4	-
-	CD557	CD559	CD558	-	-	QUS954	16 1/2	x	23 7/8	x	11	1	-
-	CD560	CD562	CD561	-	-	QUS955	18 1/4	x	23 7/8	x	12	1	-

* Mobile unit

DIVIDERS ONLY

Depth Model No.	Clear Window Model No.
CB824	-
CB825	-
CB826	-
CF501	CF560
CD250	CD266
CB829	CB814
CC569	CB814
CB829	CB815
CB830	CB818
CB831	CB818
CF394	CF396
CF395	CF397
CC297	CC300
CB831	CB819
CB833	CB820
CB834	CB821
CC298	CC301
CB835	CB822
CB835	CB822
JUMBO DIVIDERS ONLY	
CD563	CD569
CD564	CD570
CD563	CD571
CD566	CD572
CD567	CD573
CD568	CD574

OPEN HOPPER STORAGE SHELF UNITS

QUS 239 SERIES

- 28 QUS 239 Series bins 8 1/4" W x 11" D x 7" H
- Seven heavy-duty grey enamel shelves
- 36" W x 12" D x 76" H
- Cap.: 630 lbs. per shelf
- Shipped knocked down



CF118

QUS 240 SERIES

- 28 QUS 240 Series bins 8 1/4" W x 14 3/4" D x 7" H
- Seven heavy-duty grey enamel shelves
- 36" W x 12" D x 76" H
- Cap.: 630 lbs. per shelf
- Shipped knocked down



CF126

QUS 250 SERIES

- 14 QUS 250 Series bins 16 1/2" W x 14 3/4" D x 7" H
- Seven heavy-duty grey enamel shelves
- 36" W x 12" D x 76" H
- Cap.: 630 lbs. per shelf
- Shipped knocked down



CF132

QUS 240 & 230 SERIES

- 8 QUS 240 Series bins 8 1/4" W x 14 3/4" D x 7" H
- 36 QUS 230 Series bins 5 1/2" W x 11" D x 5" H
- Nine heavy-duty grey enamel shelves
- 36" W x 12" D x 76" H
- Cap.: 630 lbs. per shelf
- Shipped knocked down



CF135

Model No.						Description	No. of Shelves
Black	Blue	Yellow	Red	Ivory	Green		
QUS 239 SERIES BINS SHELF UNIT							
CF176	CF118	CF119	CF120	CF121	CF122	Starter	8
CF180	CF140	CF141	CF142	CF143	CF144	Add-On	8
QUS 240 SERIES BINS SHELF UNIT							
CF178	CF123	CF124	CF125	CF126	CF127	Starter	8
CF182	CF150	CF151	CF152	CF153	CF154	Add-On	8

Model No.						Description	No. of Shelves
Black	Blue	Yellow	Red	Ivory	Green		
QUS 250 SERIES BINS SHELF UNIT							
CF177	CF128	CF129	CF130	CF131	CF132	Starter	8
CF181	CF145	CF146	CF147	CF148	CF149	Add-On	8
QUS 240 & 230 SERIES BINS SHELF UNIT							
CF179	CF133	CF134	CF135	CF136	CF137	Starter	9
CF183	CF175	CF155	CF156	CF157	CF158	Add-On	9

PLASTIC BINS

- Designed to hang from bin racks, panels, rails and carts
- Bins reduce and control inventories, shorten assembly times and minimise parts handling
- Reinforced ribs, on both sides, prevent bins from spreading under loads
- Unaffected by weak acids and alkalis
- Stackable
- Seven available colours allow for colour coding
- Recycled plastic bins are made from 100% post consumer material, available in black only

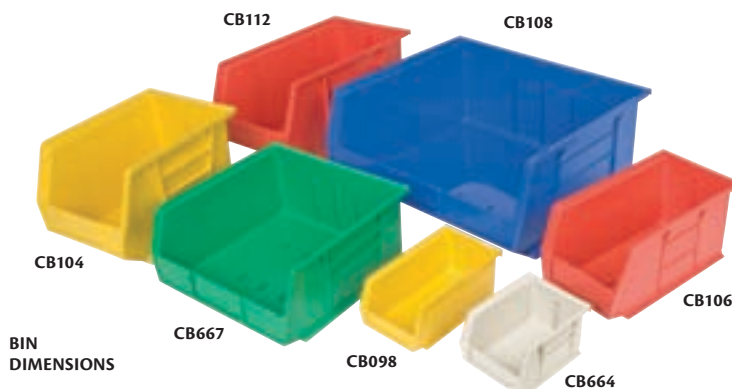
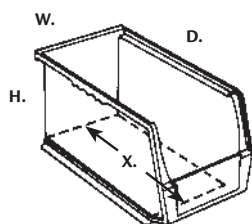

Bin Model No.							Mfg. No.	Outside Dimensions					Inside Dimensions					Bin Load Cap.**	Qty /Case	Wt. lbs.	Dividers Model No.		
Blue	Red	Yellow	Green	Stone	Clear	Black		W"	x	D"	x	H"	W"	x	D"	x	H"					x	X**"
CB093	CB094	CB095	CB663	CB664	CF427	CF434	30-210	4 1/8	x	5 3/8	x	3	3 7/16	x	4 3/4	x	2 13/16	x	4	10	24	0.2	CB124
CB096	CB097	CB098	CB665	CB666	CF428	CF435	30-220	4 1/8	x	7 3/8	x	3	3 7/16	x	6 3/4	x	2 13/16	x	6	10	24	0.3	CB125
CB099	CB100	CB101	CB667	CB668	CF429	CF436	30-230	5 1/2	x	10 7/8	x	5	4 3/8	x	10 1/4	x	4 3/4	x	9	30	12	0.8	CD513
CB102	CB103	CB104	CB669	CB670	CF430	CF437	30-235	11	x	10 7/8	x	5	10	x	10 1/4	x	4 3/4	x	9	50	6	1.5	CD514
CB105	CB106	CB107	CB671	CB672	CF431	CF438	30-239	8 1/4	x	10 3/4	x	7	6 9/16	x	10	x	6 3/4	x	8	50	6	1.5	CB128
CB108	CB109	CB110	CB673	CB674	CF432	CF439	30-240	8 1/4	x	14 3/4	x	7	6 9/16	x	14	x	6 3/4	x	12	60	12	2.0	CB129
CB111	CB112	CB113	CB675	CB676	CF433	CF440	30-250	16 1/2	x	14 3/4	x	7	14 3/4	x	14	x	6 3/4	x	12	75	6	3.5	CB129
CC287	CC289	CC288	N/A	N/A	N/A	CF523	QUS265	8 1/4	x	18	x	9	6 3/4	x	17 1/8	x	8 1/4	x	14 1/2	60	6	2.8	CC298
CB808	CB810	CB809	N/A	N/A	N/A	CF524	QUS270	16 1/2	x	18	x	11	14 3/4	x	17 1/8	x	10 1/4	x	13 3/4	-	3	5.3	CB835

* Int. Dim. X = length of bottom.

** When attached to panels, QUS265 and QUS270 may be too large to hang in certain applications.

GIANT STACKING CONTAINERS

- Designed for multiple applications in recycling, storing parts, tools and warehouse items
- Will stack up to six high creating sturdy, tall storage systems
- Large grip side handles
- Extra thick side walls with reinforcing ribs allow for 100-lb. stack capacity per bin
- 1/4" drill holes in bottom allow for drainage
- Outside dimensions: 15 1/4" L x 19 7/8" W x 12 7/16" H
- Optional clear window and labels are available

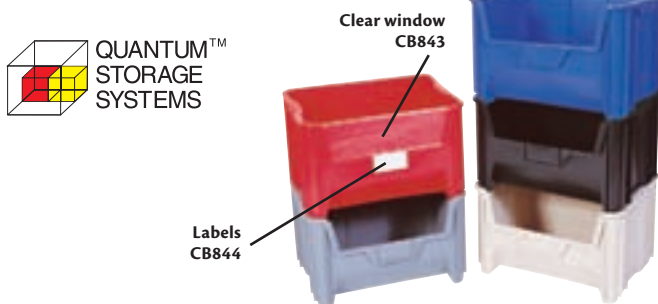

Grey	Blue	Ivory	Black	Red	Mfg. No.	Qty /Case
CB838	CB839	CB841	CB842	CC305	QGH700	3

GIANT STACK CONTAINER SHELF UNITS

- Includes 10 QGH700 storage bins and heavy-duty grey enamel shelves
- 42" W x 18" D x 76" H
- Capacity: 500 lbs. per shelf
- Shipped knocked down



Grey	Blue	Ivory	Black	Red	Description	No. of Shelves
CF056	CF057	CF059	CF060	CF066	Starter	6
CF061	CF062	CF064	CF065	CF067	Add-On	6

TRI-DEX™ LABEL HOLDERS

FOR SLOTTED PLASTIC BINS

- Locks into place with no adhesive backing required
- Insertable feature accommodates easy designation changes
- Crystal clear PVC protective window
- Barcode compatible
- Laser inserts included
- 25 holders per pack
- Replacement label inserts: 120 per sheet, 50 sheets per pack



Model No.	Dimensions"	Description	Replacement Inserts Model No.	Dimensions"
OK113	1 3/16 x 3	Ideal for Shelf Bins	OK118	11/16 x 3
OK114	1 x 3	Ideal for Bin Series 30-210, 30-220	OK119	7/8 x 3
OK115	1 1/4 x 3	Ideal for Bin Series 30-224	OK120	1 1/8 x 3
OK116	1 3/4 x 4	Ideal for Bin Series 30-230, 30-250	OK121	1 11/16 x 4
OK117	2 x 4	Ideal for Bin Series 30-265, 30-270	OK121	1 11/16 x 4



BIN PANELS & SUPPORT RACKS

METAL BIN SUPPORT RACKS

- Louvered bin panels can be wall-mounted, attached to back of shelving, mounted on benches, carts, inside cabinets, fastened to slotted angle components or used for service truck interiors
- Bins are easily removed, refilled and replaced
- Each heavy-duty panel is 16-gauge cold-rolled steel
- Slotted holes 3/4" L x 3/8" W at 6" centres simplify installation
- *Kleton* grey powder coated
- **Installation note:** Panels must be securely fastened to materials of adequate load bearing strength
- Each panel must be secured vertically at the centre

CF412



BIN QUANTITY TABLE

Quantity of identical plastic bins that fit CF412 Panel

Combined Panel Height 35 3/4" Wide	Bin	Model No.						
		CB093	CB096	CB099	CB102	CB105	CB108	CB111
1 Panel = 19" H	32	32	18	9	8	8	4	
2 Panels = 37" H	72	72	36	18	18	16	8	
3 Panels = 55" H	104	104	54	27	28	28	14	
4 Panels = 73" H	144	144	72	36	36	36	18	

For CF411 Panel, use 1/2 of bin quantities shown above

Model No.	Panel Dimensions		Wt. lbs.
	W" x H"	H"	
CF411	18 x 19	6	
CF412	36 x 19	12	



ABS PLASTIC BIN SUPPORT RACKS

- Louvered hanging panels can be wall mounted, attached to the back of shelving, mounted on benches, carts, inside cabinets, fastened to slotted angle components, or used for service truck interiors
- Bins are easily removed, refilled and replaced
- Dimensions: 24" W x 18" H
- Sold two per pack
- **Installation note:** Panels must be securely fastened to materials of adequate load bearing strength

Bins not included



Model No. CF331

COMBINED PANEL: 48" WIDE X 18" HIGH

CB093	CB096	CB099	CB102	CB105	CB108	CB111
60	60	24	12	12	12	4

Quantity of identical plastic bins that fits two panels of CF331

BINS CARTS

- All-welded bin cart
- Work surface made of 14-gauge steel
- **Includes:** 20 bins of various size, bolted-on 5" non-marking casters and two louvered panels
- Capacity: 1000 lbs.
- Durable *Kleton* blue enamel finish



CB367

BINS SUPPLIED

Bin Qty	Bin Dimensions		
	W" x D" x H"	D" x H"	H"
16	8 1/4 x 14 3/4 x 7		
4	16 1/2 x 14 3/4 x 7		

Model No.	Description	Dimensions			Wt. lbs.
		W" x D" x H"	D" x H"	H"	
CB365	Cart Only	24 x 38 1/2 x 36 1/2			95

CART/BIN COMBINATION

Blue	Red	Yellow	Green	Stone	Bin Qty	Wt. lbs.
CB366	CB367	CB368	CB689	CB690	20	133

STATIONARY BIN RACKS

- Designed to be permanently installed to the floor
- All-welded stationary bin racks
- Constructed of 1 1/4" square tube frame
- Choose from either single or double-sided racks to meet your storage needs
- Durable *Kleton* blue enamel finish
- Includes 28 or 56 bins
- 8 1/4" W x 14 3/4" D x 7" H
- Shipped all-welded



Model No.	Description	Rack Type	Dimensions			Wt. lbs.
			W" x D" x H"	D" x H"	H"	
CB373	Rack Only	Single	36 x 12 x 61			60
CB653	Rack Only	Double	36 x 24 x 61			100

RACK/BIN COMBINATION

Blue	Red	Yellow	Green	Stone	Rack Type	Bin Qty	Capacity lbs.
CB654	CB655	CB656	CB685	CB686	Single	28	1680
CB370	CB371	CB372	CB687	CB688	Double	56	3360

ACCESSORIES

Model No.	Description
CC165	Round Hook, 6"
CC166	Round Hook, 12"
CC167	Square Hook, 6"
CC168	Square Hook, 12"



MOBILE BIN RACKS

- Ideal for transportation of small parts
- All-welded mobile bin rack
- **Single** includes 36 bins
- 5 1/2" W x 10 7/8" D x 5" H, 3" casters and two louvered panels
- **Double cart** includes 96 bins of various sizes, bolted on 5" non-marking casters and six louvered panels
- Capacity: 800 lbs. single sided and 1000 lbs. double sided
- Durable *Kleton* blue enamel finish



CB090



BINS SUPPLIED

Bin Qty	Bin Dimensions		
	W" x D" x H"	D" x H"	H"
36	5 1/2 x 10 7/8 x 5		

Model No.	Description	Rack Type	Dimensions			Wt. lbs.
			W" x D" x H"	D" x H"	H"	
CB359	Rack only	Single	36 x 16 x 52			60
CB649	Rack only	Double	36 x 24 x 63			120

RACK/BIN COMBINATION

Blue	Red	Yellow	Green	Stone	Rack Type	Bin Qty	Wt. lbs.
CB650	CB651	CB652	CB681	CB682	Single	36	83
CB089	CB090	CB091	CB683	CB684	Double	96	187



DEEP DOOR COMBINATION CABINETS

- All-welded heavy-duty 16-gauge, combination bin/shelf cabinet
- 4" deep hinged doors
- Unique padlock hasp helps prevent access with bolt cutters
- Powder coated Kleton grey finish
- Padlock sold separately

A. 84 BIN CABINETS

- Four reinforced 16-gauge main adjustable shelves with 500-lb. capacity per shelf
- Incorporates louvered bin hanging panels welded into the cabinets doors

CABINET ONLY

Model No.	Description	Dimensions				Wt. lbs.	
		W"	x	D"	x		H"
CB442	Cabinet Only	38	x	24	x	72	324
FB025	Extra Shelf	38	x	18	x	1	18

CABINET WITH BINS

Model No.						Description	Wt. lbs.
Blue	Red	Yellow	Green	Stone			
CB446	CB477	CB448	CB693	CB694		Cabinet and Plastic Bins	341

BINS SUPPLIED

Bin Qty	Bin Dimensions					Capacity lbs.
	W"	x	D"	x	H"	
84	4 1/8	x	5 3/8	x	3	10

B. 96 BIN CABINETS

- Two reinforced 16-gauge main adjustable shelves with 500-lb. capacity per shelf
- Incorporates louvered bin hanging panels welded to the cabinet's back and doors

CABINET ONLY

Model No.	Description	Dimensions				Wt. lbs.	
		W"	x	D"	x		H"
FH820	Cabinet Only	38	x	24	x	72	316

CABINET WITH BINS

Model No.						Description	Wt. lbs.
Blue	Red	Yellow	Green	Stone			
CF371	CF372	CF373	CF374	CF375		Cabinet and Plastic Bins	359

BINS SUPPLIED

Bin Qty	Bin Dimensions					Capacity lbs.
	W"	x	D"	x	H"	
84	4 1/8	x	5 3/8	x	3	10
12	5 1/2	x	10 7/8	x	5	30

C. 98 BIN CABINETS

- Two reinforced 16-gauge main adjustable shelves with 500-lb. capacity per shelf
- Incorporates louvered bin hanging panels welded to the cabinet's back and doors

CABINET ONLY

Model No.	Description	Dimensions				Wt. lbs.	
		W"	x	D"	x		H"
FH820	Cabinet Only	38	x	24	x	72	316

CABINET WITH BINS

Model No.						Description	Wt. lbs.
Blue	Red	Yellow	Green	Stone			
CF355	CF356	CF354	CF357	CF358		Cabinet and Plastic Bins	385

BINS SUPPLIED

Bin Qty	Bin Dimensions					Capacity lbs.
	W"	x	D"	x	H"	
48	4 1/8	x	5 3/8	x	3	10
36	4 1/8	x	7 3/8	x	3	10
8	8 1/4	x	14 3/4	x	7	60
6	16 1/2	x	14 3/4	x	7	75



A. CB446
84 Bins



B. CF373
96 Bins



C. CF354
98 Bins



D. CB445
118 Bins

D. 118 BIN CABINETS

- Incorporates louvered bin hanging panels welded to the cabinet's back and doors

CABINET ONLY

Model No.	Description	Dimensions				Wt. lbs.	
		W"	x	D"	x		H"
CB441	Cabinet Only w/o Shelves	38	x	24	x	72	316

CABINET WITH BINS

Model No.						Description	Wt. lbs.
Blue	Red	Yellow	Green	Stone			
CB443	CB444	CB445	CB691	CB692		Cabinet and Plastic Bins	385

BINS SUPPLIED

Bin Qty	Bin Dimensions					Capacity lbs.
	W"	x	D"	x	H"	
42	4 1/8	x	5 3/8	x	3	10
42	4 1/8	x	7 3/8	x	3	10
18	5 1/2	x	10 7/8	x	5	30
12	8 1/4	x	14 3/4	x	7	60
4	16 1/2	x	14 3/4	x	7	75

SHELF BINS

SHELF BINS

- Economical way to store and display parts and components
- Durable polypropylene
- Designed for use on 12", 18" and 24" deep shelving, or vertical storage and retrieval units
- Shelf bins "nest" when empty
- Bin cups and dividers available
- Manufactured from FDA approved polypropylene

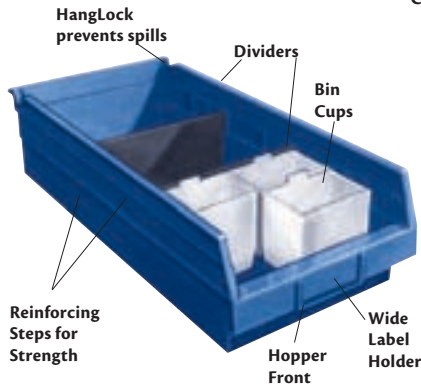

The special built-in hanglock catches the underside of the shelf above, allowing each bin to be tilted out for complete access.

Blue		Red		Model No.		Mfg. No.	Outside Dimensions			Inside Dimensions			Qty /Case	Dividers, up to 7 per bin	Bin Cups Per Bin						
CB381	CB382	CB383	N/A	CB696	30-110		W"	x	D"	x	H"	W"			x	D"	x	H"	CB379	CB380	CD036
CB384*	CB385*	CB386*	N/A	CB697*	30-120	4 1/8	x	11 5/8	x	4	3	x	10 1/4	x	4	24	CB420	5	2	N/A	N/A
CB393*	CB394*	CB395*	N/A	CB698*	30-130	6 5/8	x	11 5/8	x	4	5 1/2	x	10 1/4	x	4	12	CB421	9	4	N/A	N/A
CC393	CC394	CC395	CF531	N/A	QSB107	8 3/8	x	11 5/8	x	4	7 1/2	x	10 3/4	x	3 7/8	20	CB867	N/A	N/A	12	4
CC396	CC397	CC398	CF532	N/A	QSB109	11 1/8	x	11 5/8	x	4	10 3/8	x	10 3/4	x	3 7/8	8	CB869	N/A	N/A	18	6
CB390*	CB391*	CB392*	N/A	CB699*	30-128	4 1/8	x	17 7/8	x	4	3	x	16 1/2	x	4	12	CF021	8	3	N/A	N/A
CB396*	CB397*	CB398*	N/A	CB700*	30-138	6 5/8	x	17 7/8	x	4	5 1/2	x	16 1/2	x	4	12	CB421	15	6	N/A	N/A
CC399	CC400	CC401	CF533	N/A	QSB108	8 3/8	x	17 7/8	x	4	7 1/2	x	16 1/2	x	3 7/8	10	CB867	N/A	N/A	19	6
CC402	CC403	CC404	CF534	N/A	QSB110	11 1/8	x	17 7/8	x	4	10 3/8	x	16 3/8	x	3 7/8	8	CB869	N/A	N/A	29	9
CC405	CC406	CC407	CF535	N/A	QSB105	4 1/8	x	23 5/8	x	4	3 1/4	x	22 1/4	x	3 7/8	8	CB861	N/A	N/A	13	4
CC408	CC409	CC423	CF536	N/A	QSB106	6 5/8	x	23 5/8	x	4	5 1/2	x	22 1/4	x	3 7/8	8	CB862	N/A	N/A	21	8
CC411	CC412	CC413	CF537	N/A	QSB114	8 3/8	x	23 5/8	x	4	7 1/2	x	22 1/4	x	3 7/8	6	CB867	N/A	N/A	24	8
CC414	CC415	CC416	CF538	N/A	QSB116	11 1/8	x	23 5/8	x	4	10 3/8	x	22 1/4	x	3 7/8	6	CB869	N/A	N/A	35	16

* Two full width adjustable/removable dividers included

BIN DIVIDERS

Model No.	Mfg. No.	Width"	Qty/Case
CB420	40-120	2 7/8	24
CF021	40-128	3	72
CB861	DSB101	4 1/8	50
CB421	40-130	5 1/2	24
CB862	DSB102	6 5/8	50
CB867	DSB107	8 1/8	50
CB869	DSB109	11 1/8	50

BIN CUPS

Model No	Mfg. No.	Colour	Dimensions
CB379	30-101	White	3 1/4" x 2"
CB380	30-102	White	5" x 2 3/4"
CD036	QBC111	Yellow	3 1/4" x 1 3/4"
CD041	QBC112	Yellow	5 1/8" x 2 3/4"

EXTENDED LABEL HOLDERS, 24 PER BOX

Model No	Mfg. No.	Colour	Angle
CF398	ELH410	Black	10°
CF399	ELH415	Black	45°

RECYCLED SHELF BINS

- Manufactured from recycled 100% post consumer, high density polyethylene
- Available in black only

Model No.	Mfg. No.	Outside Dimensions			Qty /Case	Dividers Model No.		
		W"	x	D"	x	H"		
CF441	30-110BLK	2 3/4	x	11 5/8	x	4	48	N/A
CB850	QSB 101 BR	4 1/8	x	11 5/8	x	4	36	CB861
CB851	QSB 102 BR	6 5/8	x	11 5/8	x	4	30	CB862
CF442	30-128 BLK	4 1/8	x	17 7/8	x	4	24	CB420
CB954	QSB 104 BR	6 5/8	x	17 7/8	x	4	20	CB862
CB854	QSB 105 BR	4 1/8	x	23 5/8	x	4	8	CB861
CB855	QSB 106 BR	6 5/8	x	23 5/8	x	4	8	CB862
CB857	QSB 108 BR	8 3/8	x	17 7/8	x	4	10	CB867
CB860	QSB 114 BR	8 1/8	x	23 5/8	x	4	6	CB867
CC304	QSB 116B	11 1/8	x	23 5/8	x	4	6	CB869
CC241	QGH 700 BR	19 7/8	x	15 1/4	x	12 7/16	1	N/A

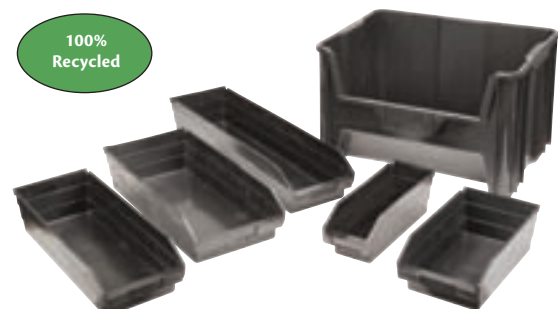

SHELF BINS & CONTAINERS



EURO DRAWERS

- Heavy-duty design for efficient organization of heavy parts, supplies, tools or equipment
- Injection molded from virgin grade high-impact polystyrene
- 12-gauge thick wall
- Completely waterproof
- Oil and chemical-resistant
- Smooth front curved pull handle has ample room for pressure sensitive identification labels or bar codes
- Front handle has 3/4" opening
- Full width back ledge ensures spill free use

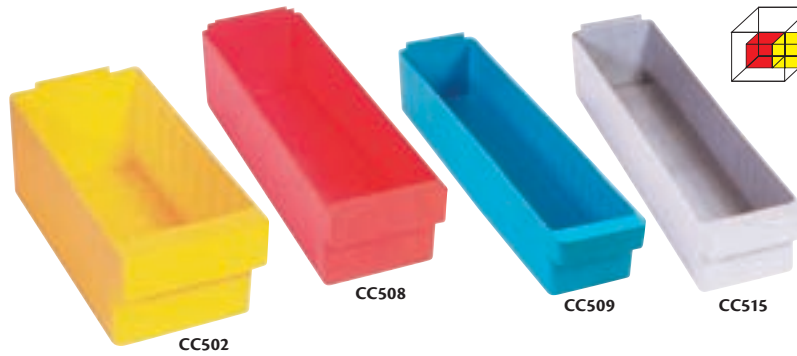

Model No.				Mfg. No.	Outside Dimensions			Qty /Case	Divider Model No.
Blue	Grey	Red	Yellow		W"	x D"	x H"		
CE289	CE291	CE292	CE290	QED401	5 9/16	x 11 5/8	x 2 5/8	24	CE309
CE293	CE295	CE296	CE294	QED501	3 3/4	x 11 5/8	x 4 5/8	24	CC518
CC501	CC503	CC504	CC502	QED601	5 9/16	x 11 5/8	x 4 5/8	24	CC517
CC505	CC507	CC508	CC506	QED602	5 9/16	x 17 5/8	x 4 5/8	24	CC517
CC509	CC511	CC512	CC510	QED603	5 9/16	x 23 7/8	x 4 5/8	12	CC517
CC513	CC515	CC516	CC514	QED604	3 3/4	x 17 5/8	x 4 5/8	24	CC518
CE305	CE307	CE308	CE306	QED606	8 3/8	x 17 5/8	x 4 5/8	24	CE312
CE297	CE299	CE300	CE298	QED701	8 3/8	x 11 5/8	x 4 5/8	24	CE312
CE301	CE303	CE304	CE302	QED801	11 1/8	x 11 5/8	x 4 5/8	12	CE314

Add dividers to Euro Drawers for additional storage possibilities!



EURO DRAWER CLOSED SHELF UNITS

- 13 heavy-duty grey enamel shelves
- Capacity: 630 lbs. per shelf
- Shipped knocked down



INCLUDES:

- 72 QED601 Series Euro drawers, 5 9/16" W x 11 5/8" D x 4 5/8" H
- Dimensions: 36" W x 12" D x 76" H

Model No.				Description	No. of Shelves
Blue	Yellow	Grey	Red		
CF102	CF103	CF104	CF105	Starter	13
CF159	CF160	CF161	CF162	Add-On	13

- 72 QED602 Series Euro drawers 5 9/16" W x 17 5/8" D x 4 5/8" H
- Dimensions: 36" W x 18" D x 76" H

Model No.				Description	No. of Shelves
Blue	Yellow	Grey	Red		
CF106	CF107	CF108	CF109	Starter	13
CF163	CF164	CF165	CF166	Add-On	13

- 108 QED604 Series Euro drawers 3 3/4" W x 17 5/8" D x 4 5/8" H
- Dimensions: 36" W x 18" D x 76" H

Model No.				Description	No. of Shelves
Blue	Yellow	Grey	Red		
CF110	CF111	CF112	CF113	Starter	13
CF167	CF168	CF169	CF170	Add-On	13

- 72 QED603 Series Euro drawers 5 9/16" W x 23 7/8" D x 4 5/8" H
- Dimensions: 36" W x 24" D x 76" H

Model No.				Description	No. of Shelves
Blue	Yellow	Grey	Red		
CF114	CF115	CF116	CF117	Starter	13
CF171	CF172	CF173	CF174	Add-On	13

JUMBO PLASTIC CONTAINERS

- Extra-large size provides massive amount of storage capacity
- Guaranteed unbreakable and distortion-free from -40°C to 120°C
- Unaffected by oil, alkaline, and most acids
- Nesting design allows for minimal storage space when not in use
- Stackable for added space savings, up to four high
- Dimensions: 15 1/2" W x 25" D x 13" H
- Capacity: 200 lbs.



Model No.	Colour
CF328	Blue
CF330	Yellow

Model No.	Colour
CF329	Green
CF327	Red

STACK-N-NEST® STORAGE BINS

- Great for storing, assembling and transporting small parts, components and finished goods
- Designed for maximum efficiency and utility
- Set together one way they stack and the other way they nest
- May be used on shelving or stacked up
- Heavy-duty design allows higher stacking
- In the plant, use the same bin for storage, handling, and assembly, no need to transfer contents



Model No.	Colour	Outside Dimensions			Wt. lbs.
		W"	x D"	x H"	
CC890	Blue	12 1/4	x 15 1/4	x 6	2
CC891	Red	12 1/4	x 15 1/4	x 6	2
CC892	Yellow	12 1/4	x 15 1/4	x 6	2

FIBREBOARD BINS & RACKS



CORRUGATED PARTS BINS & DIVIDERS

- Economical standard duty bins constructed of durable corrugated fibreboard
- Ideal for storing any loose small parts
- Assembled easily without staples or tape, just fold
- Bins are designed to hang from the shelf for hands-free access
- Bin dividers not included
- Qty per case: 100
- Shipped knocked down

Standard Corrugated Bins & Dividers



12" DEEP PARTS BINS		18" DEEP PARTS BINS		Dimensions W" x H"
Model No.	Ctn. Wt. lbs.	Model No.	Ctn. Wt. lbs.	
CB063	17	CB056	22	2 x 4 1/2
CB064	19	CB057	27	3 x 4 1/2
CB065	20	CB058	30	4 x 4 1/2
CB066	25	CB059	38	6 x 4 1/2
CB067	31	CB060	45	8 x 4 1/2
CB068	36	N/A	-	9 x 4 1/2
CB052	38	CB054	50	10 x 4 1/2
CB053	44	CB055	57	12 x 4 1/2

3 5/8" DEEP REMOVABLE DIVIDERS					
Model No.	Dimensions W" x H"	Ctn. Wt. lbs.	Model No.	Dimensions W" x H"	Ctn. Wt. lbs.
CB071	1 3/4 x 4 1/8	7	CB075	7 3/4 x 4 1/8	22
CB072	2 3/4 x 4 1/8	9	CB069	9 3/4 x 4 1/8	27
CB073	3 3/4 x 4 1/8	10	CB070	11 3/4 x 4 1/8	31
CB074	5 3/4 x 4 1/8	14			



Removable dividers ease handling

SINGLE-SIDED PICK-RACKS

- Units are free standing, but may be bolted to bench top, floor or wall
- 61" high floor model comes with 48-4" plastic storage bins and 10-6" plastic storage bins or 48-4" corrugated bins and 8-8" corrugated bins
- 21 1/2" high bench model comes with 16-4" plastic storage bins, and 5-6" plastic storage bins or 16-4" corrugated storage bins and 4-8" corrugated storage bins
- Order complete with plastic shelf bins, fibreboard bins or rack only
- Grey enamel finish
- Shipped knocked down

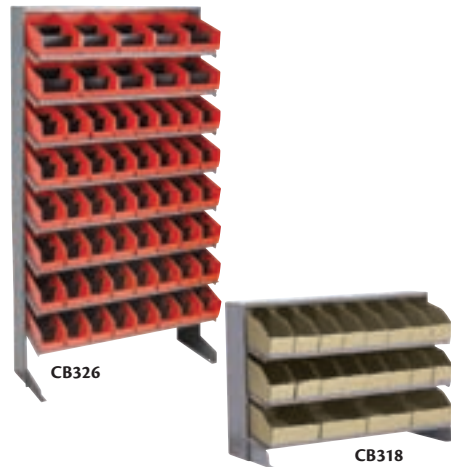

Model No.	Dimensions W" x D" x H"	Bin Type	Wt. lbs.		
CB318	32 7/8 x 12 1/8 x 21 1/2	Corrugated	22		
CB377	32 7/8 x 12 1/8 x 21 1/2	Rack Only	17		
CB323	33 1/2 x 12 1/4 x 61	Corrugated	57		
CB378	33 1/2 x 12 1/4 x 61	Rack Only	45		
Blue	Red	Yellow			
CB320	CB321	CB322	21 1/2	Plastic	25
CB325	CB326	CB327	61	Plastic	65

DOUBLE-SIDED MOBILE PICK-RACKS

- 22-gauge steel rack components mounted on a 26" x 36" dolly
- 3" casters
- Each rack accommodates 96-4" wide storage bins and 20-6" wide bins
- Order complete with plastic shelf bins, fibreboard bins or rack only
- Grey enamel finish
- Shipped knocked down

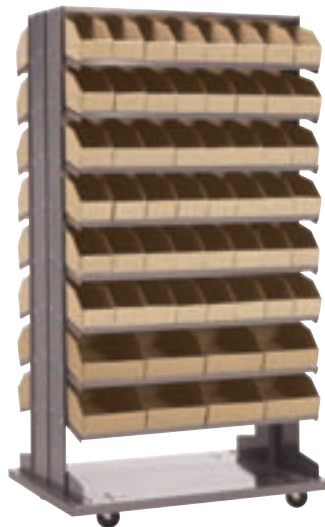

Model No.	Dimensions W" x D" x H"	Bin Type	Wt. lbs.		
CB328	33 1/2 x 12 1/4 x 65	Corrugated	139		
CB337	33 1/2 x 12 1/4 x 65	Rack Only	115		
Blue	Red	Yellow			
CB330	CB331	CB332	65	Plastic	155

PARTS STORAGE SHELVING UNITS

- Provides a versatile heavy-duty storage facility for parts storage bins
- 76" high unit comes with 96-4" bins
- 40" high unit comes with 48-4" bins
- Available with plastic shelf bins, fibreboard bins or shelving only
- Grey enamel finish
- Shipped knocked down



Model No.	Dimensions W" x D" x H"	Bin Type	Wt. lbs.		
CF048	36 x 12 x 40	Corrugated	90		
RK203	36 x 12 x 40	Shelving Only	80		
CF184	36 x 12 x 76	Corrugated	163		
RK241	36 x 12 x 76	Shelving Only	144		
Blue	Red	Yellow			
CF049	CF050	CF051	40	Plastic	96
CF053	CF054	CF055	76	Plastic	176

GIANT STACKING CONTAINERS

- Injection-molded from high density polyethylene
- Extra heavy, double wall thickness with interlock preformed lip allows containers to stack securely
- Molded carrying handle on backside
- Molded-in divider and label slots
- Optional windows available
- Can withstand temperatures ranging from -40° to 250°F
- Waterproof, will not rust or corrode
- Unaffected by chemicals and solvents
- Mobile bin comes with two swivel, two rigid 3" casters
- 300-lb. mobile capacity
- 150-lb. stack capacity

MAGNUM

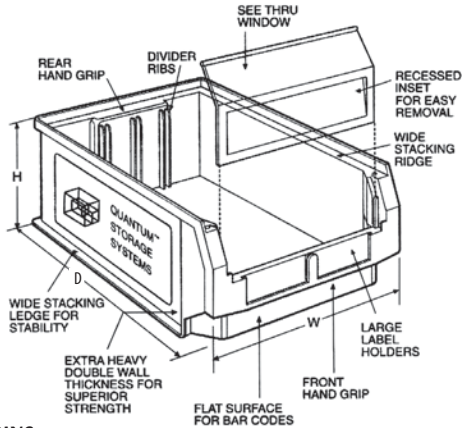

QUANTUM™ STORAGE SYSTEMS

BINS

Model No.				Mfg. No.	Outside Dimensions				Qty /Case
Blue	Green	Red	Yellow		W"	x D"	x H"		
CC361	CC362	CC363	CC364	QMS531	12 3/8	x 19 3/4	x 5 7/8	6	
CC365	CC366	CC367	CC368	QMS532	12 3/8	x 19 3/4	x 7 7/8	6	
CC369	CC370	CC371	CC372	QMS533	12 3/8	x 19 3/4	x 11 7/8	3	
CC373	CC374	CC375	CC376	QMS543	18 3/8	x 19 3/4	x 11 7/8	3	
CC377*	CC378*	CC379*	CC380*	QMS743	18 3/8	x 29	x 11 7/8	1	
CC447*	CC449*	CC448*	CC450*	QMS843MOB**	18 3/8	x 29	x 11 7/8	1	

DIVIDER

Model No.	Qty /Case
CC381	6
CC382	6
CC383	3
CC384	3
-	-

WINDOW

Model No.	Qty /Case
CC385	12
CC386	6
CC387	6
CC388	6
-	-

* Includes heavy-duty spread bar for extra strength and support. ** Mobile bins

GIANT OPEN HOPPER BIN SHELVING UNITS

- Dimensions: 42" W x 18" D x 76" H
- Capacity: 500 lbs. per shelf
- Shipped knocked down

Red	Blue	Yellow	Green	Description
SERIES QMS532				
CF072	CF073	CF074	CF075	Starter
CF089	CF090	CF091	CF092	Add-on
SERIES QMS533				
CF080	CF081	CF082	CF083	Starter
CF097	CF098	CF099	CF100	Add-on
SERIES QMS531				
CF188	CF185	CF186	CF187	Starter
SERIES QMS516				
CF189*	Starter			

* Mixed colours



CF074

SERIES QMS532

- 21 QMS532-yellow CC368
- Eight heavy-duty grey enamel shelves

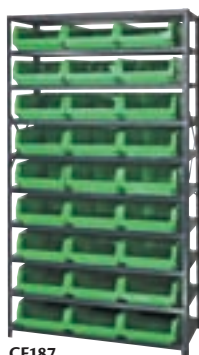

CF187

SERIES QMS531

- 27-QMS531-green CC362
- 10 heavy-duty grey enamel shelves

SERIES QMS516

- 4-QMS543-red, CC375
- 3-QMS533-blue, CC369,
- 6-QMS532-yellow CC368 and
- 3-QMS531-blue open hopper bins CC361
- Seven heavy-duty grey enamel shelves



CF189

SERIES QMS533

- 15 QMS533-blue, CC369
- Six heavy-duty grey enamel shelves



CF081

STACK-N-NEST CONTAINERS

STACK-N-NEST PLASTIC CONTAINERS

- Polylewton® Stack-N-Nest containers used in general manufacturing, food processing and distribution applications
- Injection-molded from high-impact polyolefins
- Will not rust, rot or corrode, resist damaging effects of oil, most chemical solvents, water and steam
- Stack without lids
- Nest at alternating 180° positions when empty
- Withstands wide temperature variances
- Easily cleaned

Blue & grey bins made of FDA compliant materials



CONTAINERS

CONTAINERS													LIDS				
Model No.		Mfg. No.	Outside Dim. Top			Outside Dim. Bottom			Volume	Nesting Ratio	Wt. lbs.	Grey	Red	Blue			
Grey	Red	Blue	L"	x	W"	x	H"	L"	x	W"	cu.ft.						
CA341	CC859	CC868	SN2012-6	20.1	x	13.0	x	6.2	18.5	x	11.5	0.6	2.1:1	2.1	CA334	CC877	CC883
CA344	CC860	CC869	SN2414-8	24.0	x	14.1	x	7.9	21.8	x	11.5	1.1	4:1	3.4	CA337	CC880	CC886
CA342	CC861	CC870	SN2013-12	19.4	x	12.9	x	12.1	17.3	x	10.9	1.3	4:1	3.8	CA335	CC878	CC884
CA343	CC862	CC871	SN2117-12	21.0	x	17.0	x	12.0	18.8	x	15.0	1.8	4:1	5.0	CA336	CC879	CC885
CA346	CC863	CC872	SN2618-10	26.1	x	18.7	x	10.5	24.0	x	15.9	2.1	4:1	5.4	CA339	CC882	CC888
CA348	CC864	CC873	SN3022-6	29.6	x	22.4	x	6.1	28.3	x	21.0	2.1	4:1	4.8	N/A	N/A	N/A
CA347	CC865	CC874	SN2818-10	28.4	x	18.7	x	10.5	26.0	x	15.9	2.3	4:1	5.8	N/A	N/A	N/A
CA345	CC866	CC875	SN2420-13	24.0	x	20.0	x	13.0	21.6	x	17.7	2.7	4:1	6.1	CA338	CC881	CC887
CA349	CC867	CC876	SN3024-15	30.1	x	24.0	x	15.1	27.0	x	21.0	4.7	4.5:1	11.0	N/A	N/A	N/A

STACK-N-NEST PLEXTON CONTAINERS

- Fiberglass wire-reinforced rim containers (for containers 25.3" length and greater)
- Ideal solution for heavy-duty storage, work-in-process and distribution applications
- Can withstand temperatures as low as -60°F and as high as 250°F (continuous)
- Resistant to moisture, chemicals, solvents and most oils
- Capacity: 500 lbs. per container



CONTAINERS

CONTAINERS													LIDS		DOLLIES
Model No.		Mfg. No.	Outside Dim. Top			Inside Dim. Top			Qty /Case	Red	Grey	Model No.	Model No.		
Red	Grey		L"	x	W"	x	H"	L"	x	W"	Red	Grey	Model No.		
CD179	CD193	SN1610-5	17.9	x	10.8	x	5	15.9	x	10.1	10	CD207	CD216	CD225	
CD180	CD194	SN1812-6	19.8	x	12.8	x	6	18.1	x	11.9	10	CD208	CD217	CD226	
CD181	CD195	SN1812-8	20.6	x	13.0	x	8	18.0	x	12.3	10	CC878	CA335	CD227	
CD182	CD196	SN2010-7	24.1	x	11.4	x	6.9	20.0	x	10.7	10	CD210	CD219	CD228	
CD183	CD197	SN2010-9	24.1	x	11.4	x	9	20.0	x	10.6	10	CD210	CD219	CD228	
CD184	CD198	SN2214-5	24.3	x	14.8	x	5.1	21.7	x	14.0	8	CD211	CD220	CD229	
CD185	CD199	SN2214-8	24.3	x	14.8	x	8	21.5	x	13.9	8	CD211	CD220	CD229	
CD186	CD200	SN2217-6	25.3	x	18.1	x	6.1	21.4	x	18.1	10	CD212	CD221	CD230	
CD187	CD201	SN2217-10	25.3	x	18.1	x	10.1	22.8	x	17.3	5	CD212	CD221	CD230	
CD188	CD202	SN2419-4	27.5	x	19.9	x	14.1	23.1	x	18.9	5	CD213	CD222	CD231	
CD189	CD203	SN2713-7	29.6	x	13.8	x	7	26.7	x	12.9	10	N/A	N/A	N/A	
CD190	CD204	SN2716-11	30.6	x	16.9	x	11.1	26.3	x	15.9	5	CD214	CD223	CD232	
CD191	CD205	SN3023-8	34.1	x	24.0	x	8.1	30.1	x	21.6	5	N/A	N/A	N/A	
CD192	CD206	SN3919-14	42.5	x	20.1	x	14.1	38.1	x	19.0	5	CD215	CD224	CD233	

STACK & NEST TOTES

- Will stack with or without lids for maximum storage and shipping
- Ability to stack and can be turned 180° to nest when empty
- Textured bottoms ensure safe and easy, non-slip grip transit on conveyors
- Injection-molded from high-density polyethylene material
- Will not rust, corrode or bend out of shape
- Are unaffected by chemicals and are waterproof
- Fit on standard 48" x 40" pallets
- Can withstand temperature ranges from -10°F to 250°F
- Ribs under lip prevent jamming when nested
- Handle grips on either side
- Made of FDA compliant materials



Optional lids protect container contents. As pictured, lids can be fastened and locked for added security



All nine sizes of totes have the ability to use the optional clear label holder. It securely attaches to SNT with or without lid for easy part identification.

CONTAINERS

CONTAINERS												LIDS						
Blue	Model No. Grey	Red	Mfg. No.	Outside Dimensions			Inside Dimensions			Qty /Case	Blue	Model No. Grey	Red	Qty /Case				
				L"	x	W"	x	H"	L"	x	W"	x	H"					
CC315	CC316	CC317	SNT180	18	x	11	x	6	15 1/4	x	9 3/8	x	5 7/8	6	CC342	CC343	CC344	6
CC318	CC319	CC320	SNT185	18	x	11	x	9	15 1/8	x	9 1/8	x	8 7/8	6	CC342	CC343	CC344	6
CC321	CC322	CC323	SNT190	19 1/2	x	15 1/2	x	10	16	x	13 1/4	x	9 7/8	6	CC345	CC346	CC347	6
CC324	CC325	CC326	SNT195	19 1/2	x	15 1/2	x	13	15 7/8	x	13 3/8	x	12 7/8	6	CC345	CC346	CC347	6
CC327	CC328	CC329	SNT200	19 1/2	x	13 1/2	x	8	16 3/8	x	11 1/2	x	7 7/8	6	CC348	CC349	CC350	6
CC330	CC331	CC332	SNT225	23 1/2	x	19 1/2	x	10	19 3/8	x	16 7/8	x	9 7/8	3	CC351	CC352	CC353	3
CC333	CC334	CC335	SNT230	23 1/2	x	19 1/2	x	13	19 1/2	x	16 7/8	x	12 7/8	3	CC351	CC352	CC353	3
CC336	CC337	CC338	SNT240	23 1/2	x	15 1/2	x	12	19 5/8	x	13	x	11 7/8	3	CC354	CC355	CC356	3
CC339	CC340	CC341	SNT300	29 1/2	x	19 1/2	x	15	25 1/8	x	16 5/8	x	14 7/8	3	CC357	CC358	CC359	3

Model No. CC360

Label holder, accommodates up to 3" x 5". Fits all SNT containers.

QUANTUM NESTING TOTES

- High-density polyethylene
- Rolled top rim for comfortable grip
- Eight 1/4" position drill holes on bottom allow for drainage
- Dimensions: 24 1/2" L x 19" W x 9 1/2" H
- Made of FDA approved materials

Model No. CD244 Grey

Model No. CD434 Blue



COLLAPSIBLE CONTAINERS

- Polypropylene construction
- Collapses to 21" L x 14" W x 2" H for convenient storage
- Open dimensions: 21" L x 14" W x 10 1/2" H
- Reinforced base for added durability
- 16 heavy-duty steel pins built in for increased strength
- Capacity: 160 lbs.

Model No. CF326



STAKPAK® & DIVIDER BOX® CONTAINERS

STAKPAK® PLUS 4845 SYSTEM CONTAINERS

- Stack-only, injection molded, straight-wall modular containers
- High-density polyethylene (HDPE)
- Reinforced external ribbing adds maximum stacking strength
- Smooth, straight interior walls provide maximum space utilisation and easy cleaning
- Modular design optimizes cube on standard 45" x 48" pallet, allows for mixing and matching of various sizes
- Ergonomically designed handles for comfort and safety
- Containers hold up under temperatures from -10°F to 120°F
- Optional cardholders available

ORBIS



48" x 15" (1/3)
24" x 15" (1/6)
12" x 15" (1/12)
12" x 7" (1/24)



48" x 22" (1/2)
24" x 22" (1/4)
24" x 11" (1/8)



16" x 15" (1/4)
on AIAG 30" x 32"
15" x 15" (1/9)
on AIAG 45" x 48"



12" x 15" (1/6)

Model No.			Pallet Modularity (AIAG)		Outside Dimensions		Total Container Height"	Product Clearance"	Volume cu.ft.	48' Trailer Capacity (containers)	Wt. lbs.	Lids Model No.			Cardholder Model No.
Medium Green	Grey	Royal Blue	30" x 36"	45" x 48"	Top L" x W"	Bottom L" x W"						Medium Green	Grey	Royal Blue	
STAKPAK® CONTAINERS															
CA498	CA499	CC112	1/12	1/24	12.0 x 7.4	12.0 x 7.4	5.0	4.5	0.1	8640	1.1	CA487	CA488	CC120	CA448
CA500	CA501	CC113	1/6	1/12	12.0 x 15.0	12.0 x 15.0	5.0	4.4	0.3	4320	1.6	CA489	CA490	CC121	CA448
CA502	CA503	CC114	1/6	1/12	12.0 x 15.0	12.0 x 15.0	7.5	6.8	0.5	3456	2.2	CA489	CA490	CC121	CA449
CA504	CC174	CC115	1/6	1/12	12.0 x 15.0	12.0 x 15.0	9.5	8.8	0.6	2304	2.5	CA489	CA490	CC121	CA449
CA507	CA508	CC116	-	1/6	24.0 x 15.0	24.0 x 15.0	5.0	4.5	0.7	2592	3.0	CA491	CA492	CC122	CA448
CA509	CA510	CC117	-	1/6	24.0 x 15.0	24.0 x 15.0	7.5	6.8	1.1	1728	3.6	CA491	CA492	CC122	CA449
CA511	CA512	CC118	-	1/6	24.0 x 15.0	24.0 x 15.0	9.5	8.8	1.4	1296	4.4	CA491	CA492	CC122	CA449
CA505	CA506	CC119	-	1/6	24.0 x 15.0	24.0 x 15.0	14.5	13.8	2.2	864	5.7	CA491	CA492	CC122	CA449
STAKPAK® LIDS															
CA487	CA488	CC120	-	-	12.0 x 7.4						0.4				
CA489	CA490	CC121	-	-	12.0 x 15.0						0.6				
CA491	CA492	CC122	-	-	24.0 x 15.0						2.1				
CARDHOLDERS															
Model No.		Dimensions L" x W"													
CA448		8.5	4.0												
CA449		8.5	4.6												

* When containers are stacked on top of each other approximately 1/2" is lost to nesting.

DIVIDER BOX® CONTAINERS

- Divider Box® (DC) series containers are injection-molded HDPE
- DG series are injection-molded from high-density FDA approved polyethylene which resists most solvents and chemicals
- Large, flat areas on all four sides for content identification
- Comfort grip handle
- Stacking rims and multi-ribbed external sides provide high impact strength
- All containers can be divided into compartments by length and/or width
- Molded-in stacking ridge assures containers will stack securely with or without covers
- One set of cardholder snaps and security tie holes on two ends included on DC models only
- Full range of optional accessories available including velcro card holders for DG models and snap-on card holders for DC models, vertical dividers and covers
- Optional dolly (CF400) allows for easy transport



CARD HOLDERS

Model No.			Mfg. No.	Dimensions			Volume cu.ft.	Wt. lbs.	Short Dividers		Long Dividers		Clear Lids Model No.	Snap-on or Velcro Model No.
Grey	Red	Blue		L" x W" x H"	L" x W" x H"	L" x W" x H"			Model No.	No. of Slots	Model No.	No. of Slots		
CA562	CC833	CC846	DC1025	10.8 x 8.3 x 2.5	9.2 x 6.6 x 2.5	0.07	0.5	CA568	7	CA571	5	CA556**	CC314	
CC641	CC934	CC946	DG91035	10.9 x 8.3 x 3.5	9.2 x 6.6 x 3.0	0.10	0.9	CC659	7	CC650	5	CD437*	CF351	
CC642	CC935	CC947	DG91050	10.9 x 8.3 x 5.0	9.2 x 6.6 x 4.5	0.19	1.2	CC660	7	CC651	5	CD437*	CF352	
CA565	CC836	CC849	DC2025	16.5 x 10.9 x 2.5	14.8 x 9.2 x 2.5	0.16	0.9	CA571	11	CA577	7	CA559/CA561**	CC314	
CC643	CC936	CC948	DG92035	16.5 x 10.9 x 3.5	14.9 x 9.3 x 3.0	0.24	1.42	CC661	11	CC652	7	CD438*	CF351	
CC644	CC937	CC949	DG92060	16.5 x 10.9 x 6.0	14.9 x 9.3 x 5.5	0.44	1.88	CC662	11	CC653	7	CD438*	CF352	
CA566	CC840	CC853	DC2070	16.5 x 10.9 x 7.0	15.0 x 9.3 x 7.0	0.51	1.7	CA575	11	CA581	7	CA559/CA561**	CA446/CC314	
CC645	CC938	CC950	DG92080	16.5 x 10.9 x 8.0	14.9 x 9.3 x 7.5	0.60	2.5	CC663	11	CC654	7	CD438*	CF353	
CC646	CC939	CC951	DG93030	22.5 x 17.5 x 3.0	20.6 x 15.6 x 2.5	0.44	2.5	CC664	15	CC655	11	CD439*	CF351	
CA567	CC842	CC855	DC3050	22.4 x 17.4 x 5.0	20.3 x 15.3 x 5.0	0.79	2.6	CA584	15	CA588	11	CA560/CD456**	CA446/CC314	
CC647	CC940	CC952	DG93060	22.5 x 17.5 x 6.0	20.6 x 15.6 x 5.5	0.97	4	CC665	15	CC656	11	CD439*	CF352	
CC648	CC941	CC953	DG93080	22.5 x 17.5 x 8.0	20.6 x 15.6 x 7.5	1.32	4.67	CC666	15	CC657	11	CD439*	CF353	
CC649	CC942	CC954	DG93120	22.5 x 17.5 x 12.0	20.6 x 15.6 x 11.5	2.03	5.67	CC667	15	CC658	11	CD439*	CF353	

* Grey, red and blue covers available. ** Grey and blue covers available.

DISTRIBUTION CONTAINERS

These reusable, returnable, attached-lid containers are ideal for use in wholesale product distribution and as picking containers. Hinged covers with tight interlocking fit provide maximum security and protection. Containers stack with lids closed and nest with lids open for optimum use of space in trucks, trailers or on pallets. Pebble grain bottom surface provides extra traction on conveyors. Load capacity per container is a maximum of 70-75 lbs. Bottom container will support 250 to 300 lbs. when stacked. (Please inquire for exact load capacities). *Flipak™* containers are available in polyethylene plastic (PE) and polypropylene plastic (PP).

FLIPAK™ POLYETHYLENE PLASTIC (PE) DISTRIBUTION CONTAINERS

- High-density polyethylene (HDPE) construction offers maximum product protection from moisture, impact and chemicals



ORBIS

Grey	Model No.			Outside Dimensions			Volume cu. ft.	Nesting Ratio	Wt. lbs.
	Red	Blue		Top L" x W" x H"	Bottom L" x W"				
LESS THAN 2.0 CU.FT.									
CA452	-	CF265		11.8 x 9.8 x 7.7	9.3 x 7.0		0.3	2.8:1	2.1
CA453	-	CF266		15.2 x 10.9 x 9.7	12.8 x 7.8		0.6	4.0:1	3.0
CA454	-	-		21.8 x 15.1 x 5.5	18.9 x 13.7		0.7	3.6:1	4.8
CA455	-	CF268		19.7 x 11.8 x 7.3	16.9 x 9.3		0.7	3.0:1	3.4
CA456	-	-		20.6 x 13.5 x 6.5	18.2 x 11.7		0.8	2.1:1	5.2
CA457	-	-		20.6 x 13.2 x 11.6	17.7 x 11.0		1.4	4.4:1	5.9
CF559	CF556	CF557		21.8 x 15.2 x 9.8	19.1 x 13.5		1.4	4.4:1	5.9
CA460	-	-		21.8 x 16.0 x 9.3	19.1 x 13.4		1.4	4.5:1	5.9
CA461	-	CF273		22.3 x 13.0 x 12.8	19.1 x 10.9		1.6	3.8:1	6.2
CA462	CA463	CF274		21.8 x 15.2 x 12.9	18.6 x 12.9		1.8	4.0:1	6.5
CA464	-	-		23.5 x 15.7 x 13.0	19.9 x 13.0		1.9	4.5:1	6.9
2.0 CU.FT. & GREATER									
CF504	CF503	CF506		26.9 x 17.1 x 12.6	24.3 x 14.6		2.4	4.2:1	8.2
CA468	CA469	CF277		23.9 x 19.6 x 12.6	21.1 x 17.1		2.7	5.3:1	8.4
CA470	-	-		28.0 x 20.6 x 12.5	25.0 x 18.0		3.2	3.5:1	10.0
CA471	-	-		39.0 x 14.0 x 13.0	36.3 x 11.3		3.3	4.9:1	10.4
CA472	-	-		32.0 x 18.0 x 14.9	28.8 x 15.9		3.8	3.0:1	11.0
CA473	CA474	CF281		27.9 x 20.6 x 15.6	25.8 x 18.7		4.0	2.7:1	12.7
CA475	-	-		30.0 x 22.0 x 20.5	27.4 x 19.4		6.1	4.0:1	17.0

FLIPAK™ CLEAR POLYPROPYLENE PLASTIC (PP) DISTRIBUTION CONTAINERS

- Offer all the same benefits as the polyethylene containers, plus provide easy content identification
- Polypropylene (PP) is the same family as polyethylene
- Polypropylene's advantages over polyethylene include its greater stiffness and elevated use
- Temperature range: 30°F - 150°F



ORBIS

Model No.	Outside Dimensions			Volume cu. ft.	Nesting Ratio	Wt. lbs.
	Top L" x W" x H"	Bottom L" x W"				
LESS THAN 2.0 CU.FT.						
CC128	11.8 x 9.8 x 7.7	9.3 x 7.0		0.3	2.8:1	2.1
CC129	15.2 x 10.9 x 9.7	12.8 x 7.8		0.6	4.0:1	3.0
CC130	19.7 x 11.8 x 7.3	16.9 x 9.3		0.7	3.0:1	3.4
CF558	21.8 x 15.2 x 9.8	19.1 x 13.5		1.4	4.4:1	5.6
CC132	21.8 x 15.2 x 12.9	18.6 x 12.9		1.8	4.0:1	6.2
2.0 CU.FT. & GREATER						
CF505	23.9 x 19.6 x 12.6	21.1 x 17.1		2.7	5.3:1	8.4

FLIP TOP ECONOMY STORAGE CONTAINERS

- Stack when lid is closed
- Translucent sides
- Nest when empty
- Recessed carry handles
- Dimensions: 21 1/2" L x 15" W x 12 1/2" H
- Capacity: 45 L

Model No. CD383 Black Top

Model No. CF555 Red Top



CF555

CD383

ip
INTEGRATED PLASTICS

ECONOMY FLIP TOP CONTAINERS

- Stack when lid is closed
- Nest when empty
- Recessed carrying handles
- Dimensions: 21 1/2" L x 15" W x 12 1/2" H
- Capacity: 45 L
- Weight: 5 lbs.

Model No. CD459 Grey



ip
INTEGRATED PLASTICS

FDA APPROVED POLY CONTAINERS

BUS/UTILITY BOXES

- Made of durable, commercial grade plastic
- Reinforced handles, bottom and ribs for added strength
- Dimensions: 20" L x 15" W x 5" H
- Capacity: 17.5 L
- Certified to NSF Std. #2 (splash zone)
- USDA Meat & Poultry Equipment Group Listed and assists in complying w/HACCP guidelines



Model No. CD445 Grey
Mfg. No. 3349

Model No. CD446 White
Mfg. No. 3349

Model No. CD662 Grey Cover
Mfg. No. 3648



GENERAL PURPOSE PAILS

- Snap on lids available: **Dry seal type** or **gasket type** for liquid handling
- Galvanized steel handles except **CB040**



ROPAK

Model No.	Description	Dimensions Dia" x W"	Lid Type	Wt. lbs.
CB040	4-L Pail w/Plastic Handle	8 1/4 x 6	-	0.5
CB039	Lid for Pails 4, 5, 6 L w/Static Joint	8 1/2 x 1/2	Gasket	0.2
CB043	11.4-L Pail w/Metal Handle	11 x 9	-	1.1
CB041	Lid for Pails 11.4 L w/o Static Joint	11 3/8 x 5/8	Dry Seal	0.3
CB046	20-L Pail w/Metal Handle	11 7/8 x 15 3/8	-	2.0
CC426	Lid for 20-L pail	12 1/2 x 5/8	Dry Seal	0.4
CB045	Heavy-duty Lid for 20 and 23-L Pails w/Pouring Spout	12 1/8 x 3/4	Gasket	0.6

CROSS STACK BINS

- Ideal for production, assembly and order picking
- Injection-molded from high-impact polyethylene; will not crack or rust, and easy to clean
- Can be turned 90° to cross stack
- Built-in handle and bottom grooves for easy handling
- Capacity: 100 lbs.
- Made of FDA compliant materials
- Optional clear label holder **CC360**



CONTAINERS

LIDS

Model No.			Dimensions			Model No.				
Blue	Grey	White	L"	x	W"	x	H	Blue	Grey	White
CD583	CD584	CD585	17 1/4	x	11	x	12	CF016	CD586	CF017
CD247	CD246	CD248	25 1/8	x	16	x	8 1/2	CF018	CD606	CF019

CYLINDRICAL TANKS

- Ideal for plating, compounding, pickling, and mixing
- Cylindrical tanks are self-supporting when filled
- Natural translucent walls permit visual inspection of contents at all times
- An assortment of fittings may be installed to meet the most demanding applications
- Colour: Natural white
- Other sizes available up to 500-lb. capacity
- Accepted for use in Canadian food processing facilities



Covers sold separately

TANKS

Model No.	Capacity Imp. Gal.	Inside Dia. "	Tank Depth "	Wt. lbs.	Model No.	Wt. lbs.
CA074	5	11	16	3	CA075	1
CA027	12	13	27	4	CA028	1
CA020	15	16	24	6	CA026	1
CA025	25	16	35	8	CA026	1
CA021	30	18	33	10	CA022	1
CA067	30	20	27 1/2	11	CA068	2
CA036	45	22 1/2	34	18	CA037	3
CA076	60	22 1/2	45	22	CA077	3
CA078†	75	24	48	23	CA079	3
CA034†	100	30	42	35	N/A	-
CA038†	150	36	42	45	CA039	8
CA054†	175	36	48	55	CA055	8

† F.O.B. Milton, Ontario

RECTANGULAR TANKS

- Ideal for storage and mixing at constant temperatures up to 150°F or 170°F intermittent
- Lids available for most sizes
- To prevent bulging under continuous heavy and liquid load, simple bracing of steel, plywood or lumber is recommended
- Straight sides, external lip unless otherwise stated
- Colour: Natural white
- Other sizes available up to 300 lbs.
- Accepted for use in Canadian food processing facilities



FITTINGS

A large variety of fittings are available for all types and sizes of tanks.

These include:

- Threaded taps
- True union ball valves
- Welded Boss
- Removable adaptors

TANKS

LIDS

Model No.	Capacity Imp. Gal.	Inside Dim.				Wt. lbs.	Model No.	Wt. lbs.
		L"	x	W"	x	D"		
CA110	6	11	x	11	x	15	N/A	-
CA065	15	24	x	15	x	11	N/A	-
CA069	15	45	x	22	x	5	N/A	-
CA084*	20	23	x	19	x	16	CA085	3
CA066	20	23	x	23	x	12	N/A	-
CA050	20	24	x	10	x	24	N/A	-
CA063	30	35	x	23	x	10	CA064	6
CA045**	30	30	x	14	x	24	N/A	-
CA071*	50	45	x	22	x	15	CA072	7
CA086	60	35	x	23	x	23	N/A	-
CA042†	75	42	x	24	x	24	CA043	7
CA089†	100	37	x	26	x	31	CA091	7
CA051†	140	54	x	30	x	24	CA052	11
CA030†	160	48	x	30	x	30	CA031	11
CA099†	190	60	x	30	x	30	N/A	-
CA056†	300	72	x	36	x	33	CA057	15

* Tapered sides ** Top dimensions restricted. † F.O.B. Milton, Ontario

HEAVY-DUTY TILT BINS

- Extremely durable ABS plastic housing and drawer body
- Transparent polystyrene front window for easy viewing
- Conveniently connects to each other with grooved channels on top, bottom and sides
- Shake resistant design prevents drawers from opening on their own
- Keyholes on back for wall mounting applications
- Colour: Black and grey



Model No.	No. of Drawers	Bin Dimensions					Cabinet Dimensions					Wt. lbs.
		W"	x	D"	x	H"	W"	x	D"	x	H"	
CF471	8	23/4	x	3 1/4	x	3 5/8	11 3/4	x	23/4	x	7 7/8	1.8
CF472	6	3 11/16	x	4	x	4 5/8	11 3/4	x	3 1/2	x	9 3/4	2.26
CF473	5	4 1/2	x	4 7/8	x	5 1/2	23 1/2	x	4	x	5 7/8	2.84
CF474	4	5 5/8	x	6 3/8	x	7 1/2	23 1/2	x	5 1/2	x	7 7/8	3.10

MOBILE TILT BIN RACKS

- Heavy-duty steel frame
- Durable powder coat paint finish on galvanized steel
- 3" swivel casters with brake
- Single or double-sided use
- Overall dimensions: 26 1/4" W 22" D x 57 1/2" H
- Colour: Grey



MOUNTING CHANNELS FOR MOBILE TILT BIN RACK

- Single side of mixed size tilt bins, any combination, takes up to six mounting channels per side
- Single side CF473 tilt bins only takes up to eight mounting channels per side
- CF471 and CF472 takes two bin units per level per side

Model No.	Description	Bin Units Included
CF477	Single-Sided	2 of each CF471, CF472, CF473, CF474
CF478	Double-Sided	4 of each CF471, CF472, CF473, CF474
CF475*	Cart Only	-
CF476	Mounting Channel for Tilt Bins	-
CF502	Mounting Channel for Hanging Bins**	-

* Mounting channels and bins not included

** See page 3 for hanging bins

ROTABIN STORAGE UNITS

- Revolving units allow for greater accessibility and visibility
- Shelves sit securely on ball bearings held with a solid steel pin
- Each shelf rotates smoothly and independently



28" DIAMETER

- Six permanent 14 1/2" wide compartments per shelf
- Extra CA221 dividers can be inserted on 1" centres
- Capacity: 500 lbs. per shelf

34" DIAMETER

- Five permanent 21" wide compartments per shelf
- Extra CD463 dividers can be inserted on 1" centres
- Optional removable pans for 34" diameter units allow for easy parts inventory, restocking, transporting to work area or to get weighted
- Capacity: 500 lbs. per shelf

Model No.	No. of Shelves	No. of Pans*	Unit Height"	Wt. lbs.
UNIT ONLY 28" (PANS NOT AVAILABLE)				
CA193	5	-	38	125
CA194	6	-	41	144
CA195	7	-	47	163
CA196	8	-	53	182
CA197	9	-	60	201
CA198	10	-	66	220
UNIT ONLY 34" (PANS NOT INCLUDED)				
CA225	4	60	35	135
CA226	5	75	43	162
CA227	6	90	50	188
CA228	7	105	66	215
CA229	8	120	66	240
GREY PANS FOR 34" UNIT				
CA258	-	-	-	-

* Max number of pans (pans not included)



CA229 shown with CA258 pans

STORAGE SYSTEMS

TIP-OUT™ BIN MODULAR STORAGE SYSTEMS



- Each bin has a slot for labeling
- Bins can be completely removed for replenishing or cleaning
- Uniform widths of 23.6" (for units of two to nine bins)
- Can be used free-standing or with stands and pedestals
- Transparent compartments tip out for easy access and viewing
- Two of **CB573** disc and screw set are needed for every bin
- Colour: Beige or grey

TILT BINS

Model No.		Mfg. No.	No. of Bins	Bin Dimensions			Cabinet Dimensions			Wt. lbs.
Beige	Grey			W"	x	D" x H"	W"	x	D" x H"	
CB552	CB553	QTB309	9	23 3/16	x	13 3/4 x 2 1/2	23 5/8	x	21 1/2 x 3 1/8	2.0
CB549	CB550	QTB306	6	3 1/2	x	25/8 x 3 3/4	23 5/8	x	3 5/8 x 4 1/2	3.0
CB546	CB547	QTB305	5	4 1/4	x	3 3/4 x 5 3/4	23 5/8	x	5 1/4 x 6 1/2	5.0
CB543	CB544	QTB304	4	5 5/8	x	5 x 7 1/2	23 5/8	x	6 5/8 x 8 1/8	7.0
CB540	CB541	QTB303	3	7 3/8	x	5 7/8 x 8 5/8	23 5/8	x	7 3/4 x 9 1/2	9.0
CB977	CB978	QTB302	2	11 1/16	x	8 7/8 x 13 5/8	23 5/8	x	11 7/8 x 13 7/8	14
CB975	CB976	QTB301	1	11 1/16	x	8 7/8 x 13 5/8	11 3/16	x	11 7/8 x 13 7/8	7

CB573 Two Discs and Two Screw Set (Two Needed for Each Bin Case)

TIP OUT™ FRAMES

- Assembly required



FRAME ONLY: BINS NOT INCLUDED

Model No.	Description	Dimensions			Bin Quantity Table QTB Series Bins					
		W"	x	D" x H"	302	303	304	305	306	309
FLOOR STANDS										
CB562	48" 1-Sided	23 5/8	x	8 x 52	3	5	6	7	11	16
CB563	70" 1-Sided	23 5/8	x	8 x 75	5	7	8	10	15	23
CB565	48" 2-Sided	23 5/8	x	16 x 52	6	10	12	14	22	32
CB568	70" 2-Sided	23 5/8	x	16 x 75	10	14	16	20	30	46
MOBILE FLOOR STANDS										
CB952	48" 2-Sided	23 5/8	x	16 x 52	6	10	12	14	22	32
CB953	70" 2-Sided	23 5/8	x	16 x 75	10	14	16	20	30	46
WALL FRAMES										
CB559	48"				3	5	6	7	11	16
CB561	70"				5	7	8	10	15	23
CB573	Two Discs & Two Screws Set									

HEAVY-DUTY PARTS CABINETS

- New design allows 98% use of drawer space to store larger tools or materials
- Housed in an all-welded 22-gauge galvanized steel cabinet
- I.D. card with clear plastic shield and divider included with every drawer
- Steel tabs and drawer stoppers allow for full extension without risk of spilling
- Cabinet has either polystyrene or heavy-duty ABS beige drawers
- Grey enamel finish



CA891



CF283



CC453

CA889



CD440



CA890



CF289



CF293



Model No.	No. of Drawers	Drawer Description	Drawer Dimensions			Cabinet Dimensions			Wt. lbs.
			W" x D" x H"	W" x D" x H"	W" x D" x H"				
CF311	18	Polystyrene	3.5 x 8.6 x 2.2	13.9 x 8.7 x 16.3	19				
CF312	20	Polystyrene	3.5 x 8.6 x 2.2	18.3 x 8.7 x 13.8	21				
CF314	40	Polystyrene	3.5 x 8.6 x 2.2	18.3 x 8.7 x 25.3	40				
CF313	25	Polystyrene	3.5 x 8.6 x 2.2	23.1 x 8.7 x 13.8	27				
CF315	75	Polystyrene	3.5 x 8.6 x 2.2	23.1 x 8.7 x 36.9	66				
CF305	16	Polystyrene	3.5 x 8.6 x 2.7	18.3 x 8.7 x 13.8	21				
CF304	15	Polystyrene	3.5 x 8.6 x 2.7	13.9 x 8.7 x 16.3	22				
CF306	20	Polystyrene	3.5 x 8.6 x 2.7	23.1 x 8.7 x 13.8	27				
CC453	32	Polystyrene	3.5 x 8.6 x 2.7	18.1 x 8.7 x 25.6	31				
CC454	60	Polystyrene	3.5 x 8.6 x 2.7	22.6 x 8.7 x 36.9	68				
CF298	16	ABS	4.7 x 8.6 x 2.7	23.1 x 8.7 x 13.8	24				
CA891	24	ABS	4.7 x 8.6 x 2.7	17.3 x 8.7 x 25.6	33				
CA892	48	ABS	4.7 x 8.6 x 2.7	22.6 x 8.7 x 36.9	58				
CD440*	48	ABS	4.7 x 8.6 x 2.7	22.6 x 10.8 x 36.9	66.8				
CA889	30	ABS	5.9 x 9.8 x 3.3	21.3 x 10.4 x 36.9	58				
CF289	24	Polystyrene	5.9 x 9.8 x 1.6	14.3 x 10.4 x 22.5	32				
CA890	60	Polystyrene	5.9 x 9.8 x 1.6	21.3 x 10.4 x 36.9	60				
CF293	18	Polystyrene	5.9 x 9.8 x 1.6	21.3 x 10.4 x 12.2	25				
CF283	12	ABS	6.4 x 11.3 x 2.7	23 x 11.4 x 13.8	28				
CF284	24	ABS	6.4 x 11.3 x 2.7	23 x 11.4 x 25.2	47				
CF285	36	ABS	6.4 x 11.3 x 2.7	23 x 11.4 x 36.9	60				

* Comes with locking doors

HEAVY-DUTY INDUSTRIAL CAROUSEL DRAWER CABINETS

- Create your customized carousel cabinet
- Each level accommodates four parts cabinets with same height
- For a multiple tier cabinet (maximum three tiers), you require add-on-shelves and threaded rods as per the following:
One add-on-shelf **CF402** for each level of cabinets
14" rod required for each level of **CF312** or **CF305** cabinets
25" rod required for each level of **CC453** or **CF314** cabinets
- Rotational base allows for 800-lb. capacity
- All-welded 11-gauge steel base
- Durable *Kleton* grey enamel finish



CF408 (Kit)



Model No.	Description	Dimensions			Wt. lbs.
		W" x D" x H"	W" x D" x H"	W" x D" x H"	
CF401	Base and Top Cover	27.5 x 27.5 x 4			80
CF402	Add-on Shelf	27.5 x 27.5 x 1			18
CF403	Threaded Rod - 14"	0.375 x - x 14			1
CF404	Threaded Rod - 25"	0.375 x - x 25			1.5
CF305	Parts Cabinet - 16 Drawers	18.3 x 8.7 x 14			21
CF312	Parts Cabinet - 20 Drawers	18.3 x 8.7 x 14			21
CC453	Parts Cabinet - 32 Drawers	18.3 x 8.7 x 25			31
CF314	Parts Cabinet - 40 Drawers	18.3 x 8.7 x 25			40
3 TIER CABINETS KITS					
CF405	192 Drawers	18.3 x 8.7 x 48			392
CF406	240 Drawers	18.3 x 8.7 x 48			407
CF407	384 Drawers	18.3 x 8.7 x 80			497
CF408	480 Drawers	18.3 x 8.7 x 80			600

INCLUDES:

- 12 - **CF314** - Cabinet - 40 drawers
- 1 - **CF401** - Base and Top Cover
- 2 - **CF404** - Threaded Rod 25"
- 2 - **CF402** - Add-on Shelf

PARTS CABINETS

CAROUSEL DRAWER CABINETS

- Designed to utilize open and often unused areas such as corners
- Optional turntable can be used to create a rotary carousel unit providing convenience for accessing small parts storage
- All-welded cabinets include clear drawers, dividers and I.D. labels
- Cabinet overall dimension: 12" W x 5 3/4" D x 22" H
- Blue enamel finish
- Turntable **CA912** may be set up with up to three levels of four cabinets per level

Model No.	No. of Drawers	Drawer Model No.	Drawer Dimensions				Wt. lbs.
			W"	x	D"	x H"	
CA870	60	CD441	2	x	5 5/16	x 1 3/8	10.7
CA869	48	CD442	2 1/2	x	5 5/16	x 1 3/8	10.7
CA868	30	24 x CD442	2 1/2	x	5 5/16	x 1 3/8	10.7
		4 x CD443	5 5/16	x	5 5/16	x 2 1/4	-
		2 x CD444	11	x	5 5/16	x 2 1/4	-
CA867	16	CD443	5 5/16	x	5 5/16	x 2 1/4	10.3
CA912	-	3 Tier Turntable Unit Only					40.0

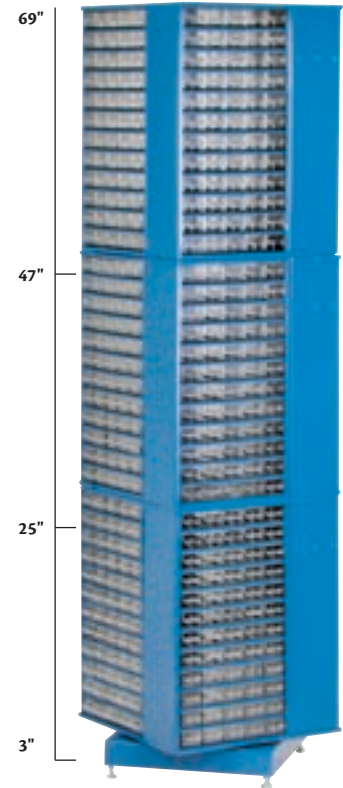
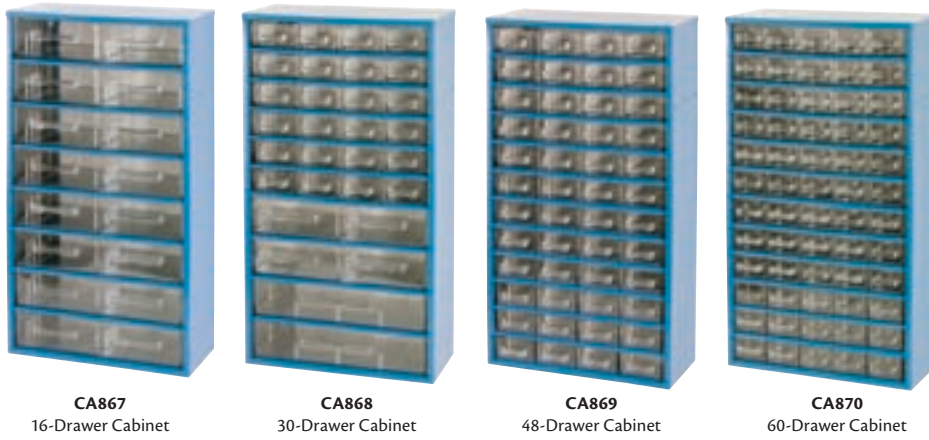

CA912 - Turntable Base
Turntable unit shown with 12 CA870 cabinets (sold separately)

ADD-A-DRAWER®

- Grey plastic drawer modules with clear windows simply slide and lock onto each other
- Can be stacked both horizontally and vertically
- Allows you to create a customized drawer cabinet
- Add on one or more units as more storage capacity is required
- Dividers and labels included



CA877

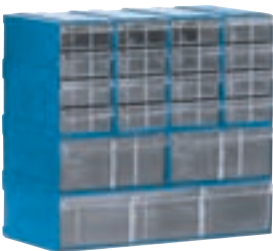

CA855



CA841 Shown with two units



CA842 Shown with two units



CA844 Shown with two units

Customize your drawer cabinet!



CD234

Model No.	No. of Drawers	Dimensions				Colour	Wt. lbs.
		W"	x	D"	x H"		
DRAWER MODULES							
CA840	2	5	x	5	x 2	Grey	0.88
CA841	1	2 1/2	x	5	x 2	Grey	0.20
CA842	1	4 1/2	x	10	x 2 1/2	Grey	1.00
CA844	1	5	x	5	x 2	Grey	0.20
CA843	4	3	x	6	x 5 3/4	Blue	1.0
CA845	2	6	x	6	x 3	Blue	1.0
CA846	1	6	x	6	x 3	Blue	1.0
CA847	1	12	x	6	x 3	Blue	1.6
CABINET KITS							
CD234	4	4 1/2	x	10 1/2	x 10	Grey	4
CD235	42	15	x	5	x 16	Grey	15.5
CA877	32	12	x	6	x 10 1/2	Blue	8.0
CA874	27	12	x	6	x 17 3/4	Blue	11.6
CA855	19	12	x	6	x 11 3/4	Blue	7.6

WORKBENCH SMALL PARTS CABINETS

- Ideal for storing small parts right on your workbench
- New design allows for 98% use of drawer space
- I.D. cards and dividers included with every drawer
- Heavy-duty ABS beige drawers
- 30 drawers, dimensions: 6.5" W x 14.8" D x 4.1" H
- Cabinet: 34.6" W x 15.7" D x 34.6" H
- Housed in an all-welded galvanized steel container finished in a grey enamel paint
- Weight: 119 lbs.

Model No. CF323



HEAVY-DUTY DRAWER CABINETS

- Heavy-duty parts cabinets feature break resistant high impact clear plastic "scoop" drawers for easy removal of small parts, with two adjustable compartment dividers
- Drawers dimensions: 2 7/8" W x 5 1/2" D x 1 7/8" H
- Welded steel cabinets are finished in grey powder coat

DURHAM
MANUFACTURING

Model No.	No. of Drawers	Cabinet Dimensions			Wt. lbs.
		W"	x	D" x H"	
CA899	64	25 1/2	x	6 1/2 x 21 3/4	34
CA898	20	16 1/2	x	6 1/2 x 11 1/4	12

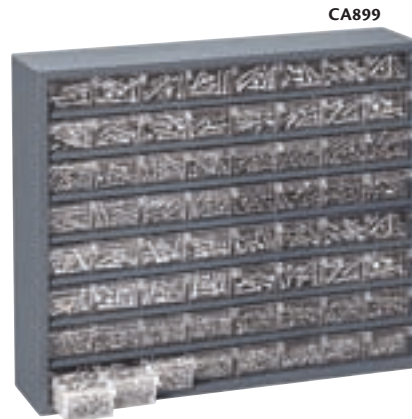

MODULAR PARTS CABINETS

- Organize and control small parts inventory
- Standard cabinets come with light grey polystyrene drawers that are virtually indestructible
- Transparent windows on drawer fronts
- Label holder on drawer pull allows for instant identification
- Comes with two removable dividers per drawer
- Stackable steel cabinet frames finished in grey baked enamel
- Cabinet frame dimensions: 17" W x 11" D x 11" H
- **Includes:** Two dividers and one label per drawer



Model No.	No. of Drawers	Drawer Dimensions			Wt. lbs.	Dividers Model No.	Replacement Drawers Model No.
		W"	x	D" x H"			
CA853	28	2 3/16	x	10 9/16 x 2 1/16	24	CB126	CA859
CA854	20	3 3/16	x	10 9/16 x 2 1/16	21	CB133	CC143
CA856	16	4	x	10 9/16 x 2 1/8	20	CA878	CA860
CA857	15	3 3/16	x	10 9/16 x 3 1/16	20	CA880	CA863
CA858	9	5 3/16	x	10 9/16 x 3 1/16	18	CA882	CA865

AKRO-MILS
CANADA

STEEL DRAWER CABINETS & CARTS

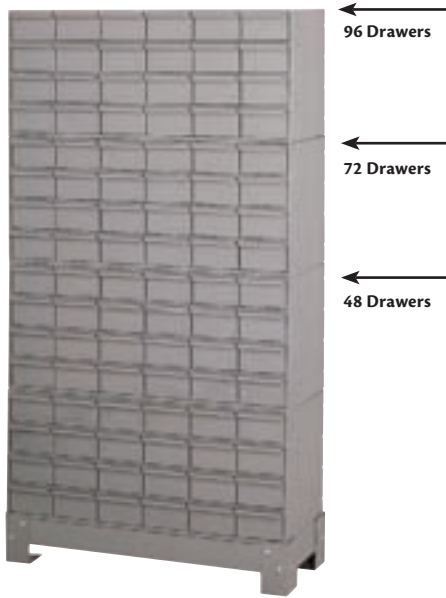

A. 48, 72 & 96-Drawer Cabinets, Base included



B. 18-Drawer Cabinets



D. 9-Drawer Cabinets



C. 24-Drawer Cabinets



E. 30-Drawer Cabinets

INDUSTRIAL DRAWER CABINETS

- Provide a rugged modular storage system for small parts
- Select from a range of drawer capacities from 9 drawers to 96 drawers per cabinet
- Various drawer sizes are available including drawer heights of 2 3/4" and 3 1/2", and drawer depths of 11 1/8" and 17"
- Each drawer includes two adjustable dividers and full width handles
- Drawer sides are slotted to hold dividers

Type	Model No.	No. of Drawers	Drawer Dimensions					Cabinet Height"	Wt. lbs.	Replacement Drawers
			W"	x	D"	x	H"			
A	FI356	30	5 3/8	x	11 1/8	x	3 1/2	26 7/8	107	CD661
A	CA936	48	5 3/8	x	11 1/8	x	2 3/4	33 3/4	176	CA921
A	FI357	60	5 3/8	x	11 1/8	x	3 1/2	48	194	CD661
A	CA939	72	5 3/8	x	11 1/8	x	2 3/4	48 1/8	238	CA921
A	FI358	90	5 3/8	x	11 1/8	x	3 1/2	69 1/8	281	CD661
A	CA941	96	5 3/8	x	11 1/8	x	2 3/4	62 1/2	300	CA921
B	CA924	18	5 3/8	x	11 1/8	x	2 3/4	10 7/8	50	CA921
B	CA925	18	5 3/8	x	11 1/8	x	3 1/2	12 7/8	87	CD661
B	CA926	18	5 3/8	x	17	x	3 1/2	12 7/8	75	CA923
C	CA930	24	5 3/8	x	11 1/8	x	2 3/4	14 3/8	60	CA921
C	CA932	24	5 3/8	x	17	x	3 1/2	17	96	CA923
D	CA942	9	5 3/8	x	11 1/8	x	2 3/4	10 7/8	28	CA921
E	CA934	30	5 3/8	x	11 1/8	x	3 1/2	21 1/8	87	CD661
E	CA935	30	5 3/8	x	17	x	3 1/2	21 1/8	118	CA923
-	CA946	Extra Divider for 2 3/4" H Drawer						-	0.1	-
-	CA947	Extra Divider for 3 1/2" H Drawer						-	0.1	-

DURHAM
MANUFACTURING

HEAVY-DUTY 2-SIDED MOBILE CART/WORK STATIONS

- Two rigid and two swivel casters with locking brakes
- Sturdy tubular handle allows ease of mobility
- Rubber tray mat provides safe, secure, non-skid work surface
- Finished in rust and acid resistant grey powder coat
- Heavy-duty casters, capacity of 1000 lbs.
- Shipped fully welded



- Two 12-compartment bins back-to-back
- Overall dimensions: 34" W x 24" D x 32" H
- Ship weight: 139 lbs.

Model No. CD330



- Two 40-compartment bins back-to-back
- Overall dimensions: 34" W x 24" D x 32" H
- Ship weight: 159 lbs.

Model No. CD349

DURHAM
MANUFACTURING



Front

- One lockable 4-compartment storage cabinet
- One storage bin with 12 compartments
- 12 easily dividable pull out storage drawers, six on each side
- Overall dimensions: 34" W x 24" D x 36" H
- Ship weight: 180 lbs.

Model No. CD348



Back

STEEL STORAGE BINS

- Pigeonhole type steel storage bin units organize small parts
- Best suited where space is limited and organization is crucial
- Produced of prime cold rolled steel
- Fully welded, will not warp, twist or sag
- Fully hemmed label holders provide adequate space for content identification
- Each divider is hemmed in a tear drop design to avoid sharp edges
- Doors with padlock attachment and bases to raise units are available with most models
- All units are 33 3/4" wide and are available in depths of 12" or 8 1/2"
- 12" deep units feature a 45° slope front for easy removal of parts
- Finished in grey powder coat

DURHAM
MANUFACTURING

Perfect for organizing your shop - can be filled with just about anything!



CA151

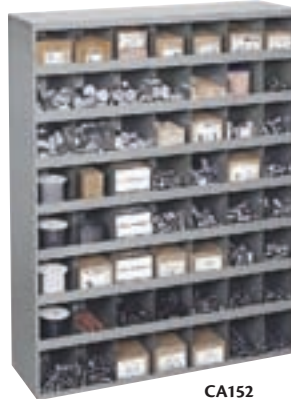

CA152



CA154



CA136



CA133

Doors for storage bins



CA151 with CA141 and CA157

Base for storage bins



CA157



CA149

Model No.	Base Model No.	Door Model No.	Dimensions					No. of Bins	Bin Dimensions					Wt. lbs.
			W"	x	D"	x	H"		W"	x	D"	x	H"	
12" DEEP STORAGE BINS														
CA133	CA157	-	33 3/4	x	12	x	11 1/2	16	4	x	11 7/8	x	5 1/8	25
CA134	CA157	-	33 3/4	x	12	x	19 1/4	18	5 3/8	x	11 7/8	x	6 3/8	38
CA136	CA157	CA142	33 3/4	x	12	x	23 7/8	24	5 3/8	x	11 7/8	x	5 1/2	44
CA149	CA157	CA142	33 3/4	x	12	x	23 7/8	40	4	x	11 7/8	x	4 1/2	50
CA151	CA157	CA141	33 3/4	x	12	x	42	42	5 3/8	x	11 7/8	x	5 1/2	71
CA152	CA157	CA141	33 3/4	x	12	x	42	56	4 7/8	x	11 7/8	x	5 1/8	75
CA154	CA157	CA141	33 3/4	x	12	x	42	72	4	x	11 7/8	x	4 1/2	80
8 1/2" DEEP STORAGE BINS														
CA150	CA158	CA148	33 3/4	x	8 1/2	x	22 1/4	40	4	x	8 3/8	x	4 1/2	50
CA155	CA158	CA141	33 3/4	x	8 1/2	x	42	72	4	x	8 3/8	x	4 1/2	70

PLASTIC COMPARTMENT CASES

COMPARTMENT BOX CABINETS

- All-steel grey baked enamel cabinet holds five plastic compartment boxes
- Bolt holes permit stacking and keyhole slots are furnished for wall mounting



DURHAM
MANUFACTURING

Model No.	Description	Dimensions				Wt. lbs.	
		W"	x	D"	x	H"	
CB631	Small	11 1/4	x	6 3/4	x	10 3/4	7
CB632	Large	13 1/2	x	9 1/8	x	13 1/4	11

COMPACT POLYPROPYLENE COMPARTMENT BOXES

- High strength, oil resistant polypropylene, boxes with covers fitted with heavy-duty reinforced hinges
- Hinges have a special "stop" feature which allows the cover to remain in open position
- Covers overlap on all sides of the bottom tray
- Two snap latches assure secure closure
- Stackable



DURHAM
MANUFACTURING

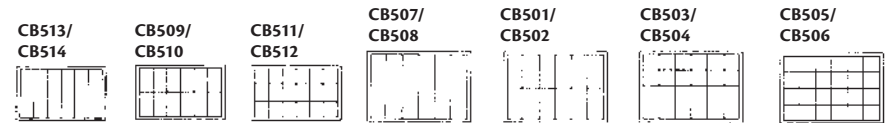

Model No.	Overall Dimensions				No. of Compartments	Compartment Dimensions				Wt. lbs.	
	W"	x	D"	x	H"	W"	x	D"	x	H"	
CB513	11	x	6 3/4	x	13/4	1 3/4	x	6 1/4	x	1 9/16	0.7
CB509	11	x	6 3/4	x	13/4	1 3/4	x	3 1/8	x	1 9/16	0.7
CB511	11	x	6 3/4	x	13/4	1 3/4	x	2 1/16	x	1 9/16	0.7
CB507	13 1/8	x	9	x	2 5/16	2	x	8 1/2	x	2	0.8
CB501	13 1/8	x	9	x	2 5/16	2	x	4 3/32	x	2	0.8
CB503	13 1/8	x	9	x	2 5/16	2	x	(6) 4 3/4 (12) 2	x	2	0.8
CB505	13 1/8	x	9	x	2 5/16	2	x	2	x	2	0.8

LARGE CASES

18 1/2" L x 13" W

- Large *Super Satchel* organize tool cribs, maintenance departments, shop floors and allow complete portability
- Lighter weight: 3.5 lbs. vs. 8 lbs. in metal
- See-through lids allow quick identification of contents
- Copolymer resins will not rust
- Brass pinned hinges provide strength and durability
- Identification card holder for quick case selection
- Molded integral feet, making ideal presentation cases

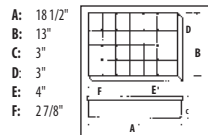

CB496
24 compartments
Wt.: 3.5 lbs.

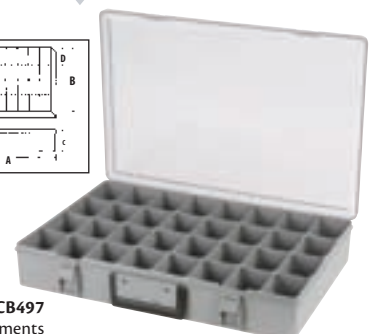
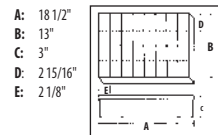

CB497
8 to 32 compartments
24 partitions provided
Wt.: 3.5 lbs.

SMALL CASES

15" L x 11 3/4" W

- Small *Satchel* store and organize large, medium, small and flat parts, removable partitions
- See-through lids allow quick identification of contents
- Copolymer resins that will not rust or dent
- Brass pinned hinges provide strength and durability
- Divided style (CB499) or double case (CB500) with two cases sonically welded back to back
- Can be stored flat or upright

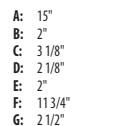

CB499
9 to 24 compartments
Wt. 2.9 lbs.

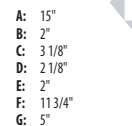

Flambeau



CB500
10 to 25 compartments
Wt. 5.8 lbs.

STEEL COMPARTMENT CASES

COMPARTMENT STEEL SCOOP BOXES

- Manufactured of prime cold-rolled steel
- Fixed compartment boxes
- Choose from between 8 and 32 fixed compartment boxes
- Small box dimensions: 13 3/8" W x 9 1/4" D x 2" H
- Large box dimensions: 18" W x 12" D x 3" H
- Finished in rust and acid resistant baked enamel
- Boxes have inserts of high impact plastic
- Inserts have rounded scoops, making it easy to remove small parts
- All models have covers designed to stay open
- See chart below for box configurations



FIXED COMPARTMENT CONFIGURATIONS, ORDER BY NUMBER OF COMPARTMENTS



LARGE COMPARTMENT BOXES 18" W x 12" D x 3" H

SMALL COMPARTMENT BOXES 13 3/8" W x 9 1/4" D x 2" H

Number of Compartments	Model No.	Wt. lbs.	Model No.	Wt. lbs.
8	-	-	CB032	4
12	CA986	8	CB015	4
16	CA989	8	CB017	4
20	CA992	8	CB023	4
21	CA995	8	CB026	4
24	CA997	8	CB029	4
32	CB002	8	-	-

COMPARTMENT BOX CABINETS

- Carriages extend 100% of the drawers depth for easy access to parts
- Flexibility of removable drawers and a large selection of drawer configurations
- Drawer cabinet may be mounted on a raised base
- Cabinets are available for both the small and large drawer sizes
- Boxes and base are sold separately
- Optional locking hinge (CB037) prevents boxes from sliding out during transport



Cabinet and boxes sold separately

Model No.	Dimensions W" x D" x H"	For Drawer	Drawer Capacity	Wt. lbs.
CA963	20 x 15 3/4 x 8 1/8	Large	2	20
CA965	20 x 15 3/4 x 15	Large	4	34
CA972	15 1/4 x 11 3/4 x 11 1/4	Small	4	22
CA975	15 1/4 x 11 3/4 x 16 3/8	Small	6	32
CB037	Optional Locking Hinge for CA972	-	-	-
CB038	Optional Locking Hinge for CA965 and CA975	-	-	-



ADJUSTABLE COMPARTMENT BOXES

- Adjustable drawers provide the added flexibility of arranging your drawers according to your changing needs
- Removable dividers can be "slotted" into place or removed altogether



Model No.	Dimensions W" x D" x H"	Description	Wt. lbs.
CA977	18 x 12 x 3	Large	8
CA979	13 3/8 x 9 1/4 x 2	Small	4

CABINET BASES

- Cabinet bases raise your cabinet/drawer combination 12" off of the floor or workbench
- Models are available to adapt to both small and large drawer size cabinets



Model No.	Overall Dimensions W" x D" x H"	For Drawer	Wt. lbs.
CA980	20 3/8 x 16 x 15 1/8	Large	13
CA983	15 1/2 x 12 1/8 x 15 1/8	Small	12

STACKBIN® CONTAINERS

STEEL STACKBINS®

- Hopper-front steel *Stackbins*® are available with capacities from 70 cubic inches up to 5100 cubic inches
- They may be easily stacked one on top of another, or housed in steel *Stackracks*®, together with *Stackracks*® base allowing lower units to be removed without disturbing units stacked above them
- Standard blue baked enamel finish

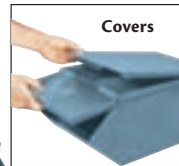

PLASTIC STACKBINS®

- Available in two types and sizes of plastic
- **CB310, CB311, CB312** and **CB313** are molded of polypropylene and have a capacity of 200 cubic inches
- **CB314, CB315, CB316** and **CB317** are molded of polyethylene and have a capacity of 1600 cu. in.
- The exclusive interlocking front bar prevents the bins from spreading under heavy loads



STACKBIN

Model No.				Wt.
Blue	Grey	Red	Yellow	lbs.
5 1/2" W X 12" D X 4 1/2" H				
CB310	CB311	CB312	CB313	0.8
12" W X 20 1/2" D X 9 1/2" H				
CB314	CB315	CB316	CB317	4

STACKBIN

Model No.	Capacity Cu. in.	Dimensions				Wt. lbs.	Top Cover Model No.	Front Cover Model No.
		W"	x	D"	x	H"		
CA765	70	4 1/2	x	8	x	4 1/2	-	-
CA766	200	5 1/2	x	12	x	4 1/2	CD369	CD368
CA767	500	7 1/2	x	15 1/2	x	6	CD370	CA734
CA768	900	9	x	18 3/4	x	7 1/2	CA706	CA735
CA772	1400	10	x	24	x	8	CA710	CA739
CA769	1600	12	x	20 1/2	x	9 1/2	CA707	CA736
CA770	2800	15	x	24	x	11	CA708	CA737
CA771	5100	18	x	30	x	12	CA709	CA738

STACKRACKS®

- *Stackracks*® are designed to be teamed up with *Stackbins*® to create a heavy-duty storage system
- *Stackracks*® allow for bins to be removed easily from a setup
- Can support any weight that fits within the cube of the coinciding container
- Easily stack together without tools or fasteners and feature *Stackbins*® patented locking system
- Can be reconfigured or added to at any time

Shown with 10 - CA769 bins, 10 - CA776 single *Stackracks*® and 1 - CA693 Base 2 bins wide



12" HIGH BASES

- Can be butt-up to each other to make continuous rows of storage bins
- Bases are made specifically for each size steel container
- 14-gauge legs and supports
- Spot welded
- Capacity: 1000 lbs.

Model No.	Description
1-BIN WIDE	
CA687	For <i>Stackracks</i> ® CA775
CA692	For <i>Stackracks</i> ® CA776
CA696	For <i>Stackracks</i> ® CA778
CA699	For <i>Stackracks</i> ® CA779
2-BIN WIDE	
CD448	For <i>Stackracks</i> ® CA774
CA688	For <i>Stackracks</i> ® CA775
CA703	For <i>Stackracks</i> ® CA780
CA693	For <i>Stackracks</i> ® CA776
CA697	For <i>Stackracks</i> ® CA778
CA700	For <i>Stackracks</i> ® CA779
3-BIN WIDE	
CD449	For <i>Stackracks</i> ® CA774
CA689	For <i>Stackracks</i> ® CA775
CA704	For <i>Stackracks</i> ® CA780
CA694	For <i>Stackracks</i> ® CA776

STACKBIN

STACKRACKS®

Model No.	Description	Wt. lbs.
CD447	For Bin CA765	3.5
CA773	For Bin CA766	4
CA774	For Bin CA767	5.5
CA775	For Bin CA768	8.5
CA780	For Bin CA772	9
CA776	For Bin CA769	10
CA778	For Bin CA770	12
CA779	For Bin CA771	14

STACKRACKS® COVERS

Model No.	Description
CA715	For CA775
CA730	For CA780
CA720	For CA776
CA724	For CA778
CA727	For CA779

SECTIONAL STACKBINS® SYSTEMS

- Sectional *Stackbin*® units are an economical alternative to standard *Stackbins*®
- Individual compartments are created from a standard 37" wide unit divided by welded steel partitions
- Each unit may be stacked on a larger, or similar sized unit, with covers and bases to complete the unit

Model No.	Dimensions				Bins in Section	Wt. lbs.
	W"	x	D"	x	H"	
SECTIONAL STACKBINS®						
CA786*	37	x	8	x	4 1/2	8 11.0
CA787*	37	x	12	x	4 1/2	6 13.8
CA788	37	x	15 1/2	x	6	5 20.0
CA789	37	x	18 3/4	x	7 1/2	4 29.0
CA790	37	x	20 1/2	x	9 1/2	3 35.0
CA791	37	x	24	x	11	2 40.0

* No bases available

Model No.	Description	Model No.	Description
SECTIONAL BASES			
CA793	For CA788	CA797	For CA786
CA794	For CA789	CA798	For CA787
CA795	For CA790	CA799	For CA788
CA796	For CA791	CA800	For CA789
		CA801	For CA790
		CA802	For CA791

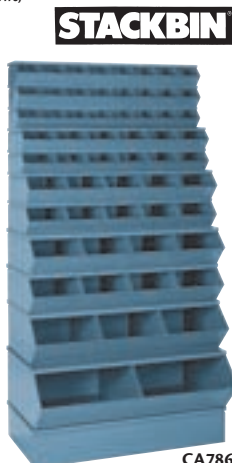

CA786

PRE-ENGINEERED SECTIONAL SYSTEMS

- Complete with sectional *Stackbin*® 6" high base and top cover
- 5000-lb. stocking capacity

Model No.	Description	Wt. lbs.
USING CA788 SECTIONAL STACKBINS®		
CD354	7 Row Unit w/35 Compartments	136.5
CD355	8 Row Unit w/40 Compartments	156
USING CA789 SECTIONAL STACKBINS®		
CD356	6 Row Unit w/24 Compartments	174
CD357	7 Row Unit w/28 Compartments	226.5
USING CA790 SECTIONAL STACKBINS®		
CD358	5 Row Unit w/15 Compartments	200
CD359	6 Row Unit w/18 Compartments	235
USING CA791 SECTIONAL STACKBINS®		
CD360	4 Row Unit w/8 Compartments	183.5
CD361	5 Row Unit w/10 Compartments	222.5



CD361

BULK STACKING CONTAINERS

- Heavy-duty all-welded construction
- Mesh containers use 2" x 2" x 10 gauge wire mesh
- All containers use a 13-gauge corrugated sheet steel base
- 2" x 2" x 3/16" angle posts
- 4-way fork truck entry with 4" underclearance
- Available with one drop gate or fully enclosed sides
- Height: 24" inside, 30" overall
- Stackable up to five high
- Other sizes are available
- Painted durable *Kleton* blue



Model No.	Description	Dimensions W" x L"	Capacity lbs.	Wt. lbs.
MESH CONTAINERS				
CF449	Fully Enclosed	34 1/2 x 40 1/2	3000	125
CF450	One Drop Gate	34 1/2 x 40 1/2	3000	130
CF451	Fully Enclosed	40 1/2 x 48 1/2	3000	150
CF452	One Drop Gate	40 1/2 x 48 1/2	3000	160
SHEET CONTAINERS				
CF453	Fully Enclosed	34 1/2 x 40 1/2	3500	150
CF454	One Drop Gate	34 1/2 x 40 1/2	3500	150
CF455	Fully Enclosed	40 1/2 x 48 1/2	3500	185
CF456	One Drop Gate	40 1/2 x 48 1/2	3500	185
CORRUGATED CONTAINERS				
CF457	Fully Enclosed	34 1/2 x 40 1/2	4500	160
CF458	One Drop Gate	34 1/2 x 40 1/2	4500	160
CF459	Fully Enclosed	40 1/2 x 48 1/2	4500	195
CF460	One Drop Gate	40 1/2 x 48 1/2	4500	195

COLLAPSIBLE STRUCTURAL POLYETHYLENE CONTAINERS

- Sturdy, long-lived and quick to erect or knock down
- Fully recyclable containers replace tons of corrugated paper and wood packaging waste
- These space-efficient collapsible containers cube out trailers and ISO containers
- Collapsible to one-third their height for space-saving return shipment
- Stack safely, full or folded to create warehouse space without racking
- Models featured below include two drop gates (one drop and no drop also available)
- Capacity: 2000 lbs



Model No.	Ext. Dimensions L" x W" x H"	Cap. Cu. Ft.	Return Ratio	Wt. lbs.	Cover Model No.
CF447	48 x 45 x 25	19.7	2:1	115	CC171
CF448	48 x 45 x 34	29.4	3:1	140	CC171
CF445	48 x 40 x 34	24.9	3:1	150	CC170
CF446	48 x 40 x 39	29.8	3:1	160	CC170
CF443	30 x 32 x 25	8.7	2:1	60	CC169
CF444	30 x 32 x 34	12.9	3:1	80	CC169

Prices F.O.B. Mississauga, Ont.

OPEN MESH CONTAINERS

- Rugged construction ensures long-lasting, trouble-free service
- 3/4" - 13 gauge expanded metal mesh panels
- Two half drop gates
- 4-way fork truck access
- 4 1/4" underclearance
- Overall dimensions:
34 1/2" W x 40 1/2" L x 32 1/4" H
- Stackable up to five high
- 15 cu.ft. capacity
- Deck capacity: 2500 lbs. mesh deck, 3000 lbs. sheet metal deck
- Blue enamel finish



Model No.	Style	Wt. lbs.
CA397	Mesh Deck	105
CA398	Sheet Metal Deck	114
CA368	Replacement Foot	0.72

STACKING RACKS

- Rugged all-welded 2" square tubing steel construction
- Utilise warehouse airspace and lower the chances of damage that is associated with bulk stacking
- Designed for storage of loose and palletised goods
- Holds 4000 lbs per rack and can be stacked four high
- Posts and bases are sold separately
- Durable *Kleton* blue enamel finish



Model No.	Inside Dim. W" x D"	Overall Dim. W" x D"	Wt. lbs.
OPEN BASE			
RL414	38 x 44	42 x 48	85
RL415	44 x 48	48 x 48	90
CLOSED BASE			
RL416	38 x 44	42 x 48	110
RL417	44 x 44	48 x 48	115



ACCESSORIES

Model No.	Description	Overall Dim. W" x H"	Wt. lbs.
RL418	42" Side Rail	42 x 48	30
RL419	48" Side Rail	48 x 48	32
RL420	42" Upright Post-Pack of 4	2 x 42	35
RL421	48" Upright Post-Pack of 4	2 x 48	40
RL422	60" Upright Post-Pack of 4	2 x 60	50



COLLAPSIBLE WIRE CONTAINERS

- Welded, square mesh wire allows full visibility and excellent ventilation
- Foldable and constructed of durable 3-gauge wire
- 4-way entry for easy use with lift trucks
- Convenient drop gate design for easy access to products
- Safety rating plates with static load capacity and static load height
- Stack up to four high
- 4" under clearance



Model No.	Dimensions W" x D" x H"	Usable Height"	Drop Gate	Mesh Dim."	Cap. lbs.	Wt. lbs.
CF462	20 x 32 x 21	16	32" Side	1 x 1	1000	43
CF463	20 x 32 x 21	16	32" Side	1/2 x 1/2	1000	55
CF464	32 x 40 x 34	28	40" Side	2 x 2	4000	122
CF465	40 x 48 x 30	24	48" Side	2 x 2	4000	150
CF466	40 x 48 x 36	30	48" Side	2 x 2	4000	163
CF467	40 x 48 x 36	30	40" End	2 x 2	4000	163
CF468	40 x 48 x 42	36	48" Side	2 x 2	4000	176